

Oct. 31, 1967

O. L. BROWN ET AL

3,349,949

RING-SHAPED TAB FOR TEAR STRIPS OF CONTAINERS

Filed July 6, 1965

3 Sheets-Sheet 1

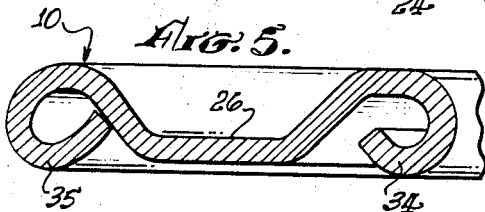
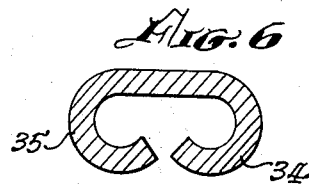
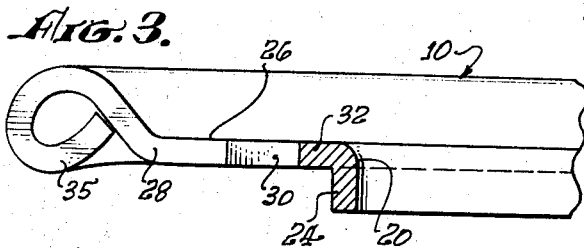
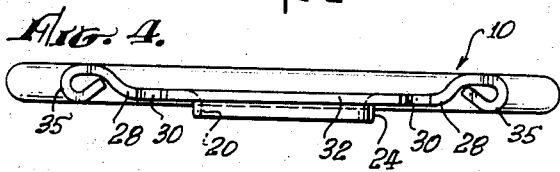
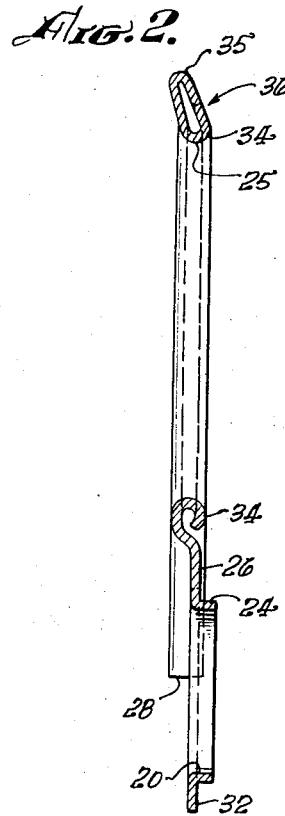
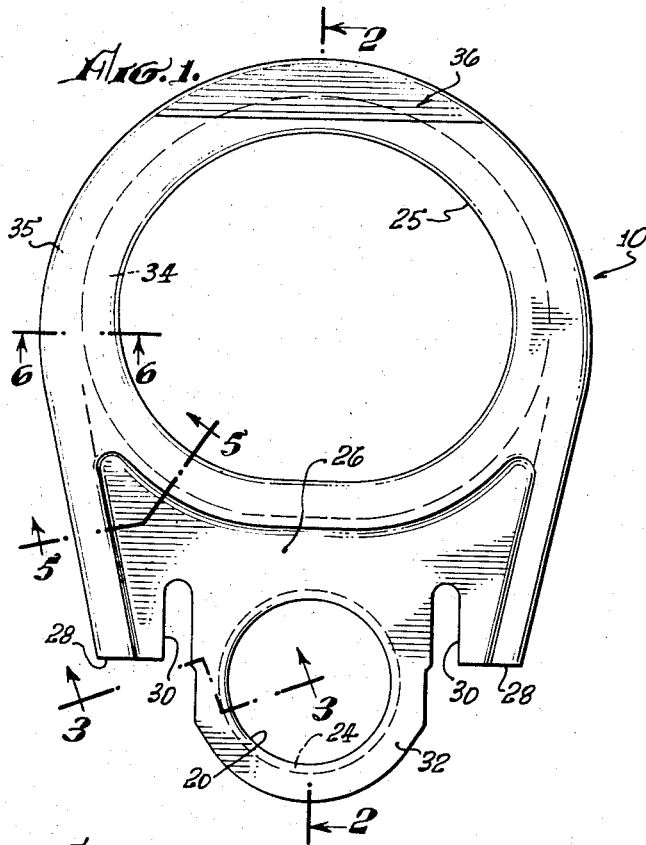

DONALD B. PETERS,  
OMAR L. BROWN,  
INVENTORS

By *Smyth, Roston & Lavitt,*  
ATTORNEYS

Oct. 31, 1967

O. L. BROWN ET AL

3,349,949

RING-SHAPED TAB FOR TEAR STRIPS OF CONTAINERS

Filed July 6, 1965

3 Sheets-Sheet 2

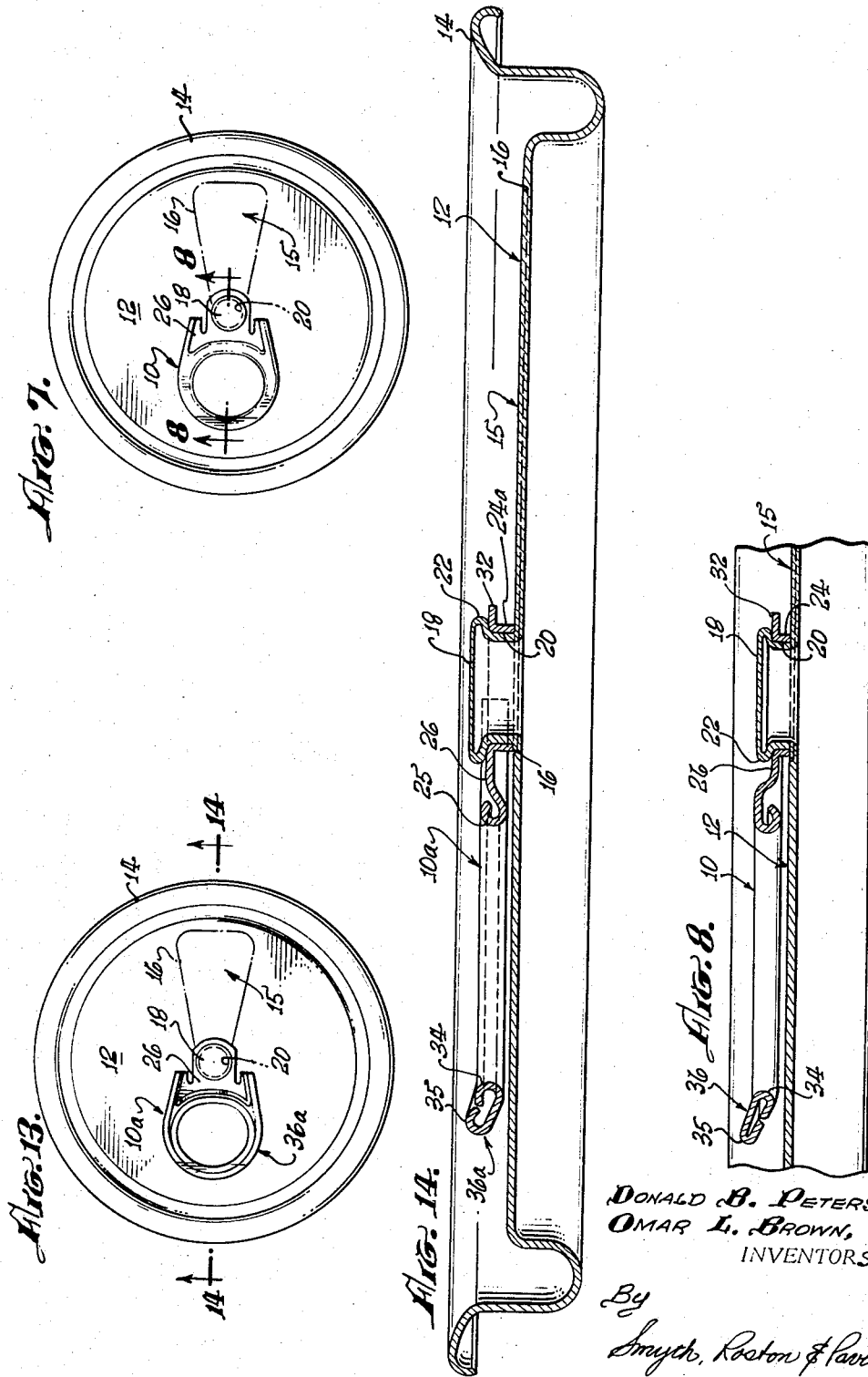

DONALD B. PETERS,  
OMAR L. BROWN,  
INVENTORS.

By  
*Smyth, Roston & Parrott*  
ATTORNEYS.

Oct. 31, 1967

O. L. BROWN ET AL

3,349,949

RING-SHAPED TAB FOR TEAR STRIPS OF CONTAINERS

Filed July 6, 1965

3 Sheets-Sheet 3

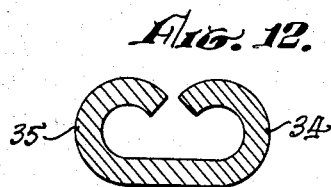
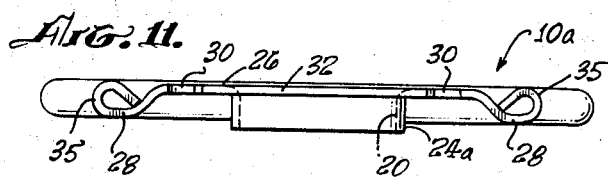
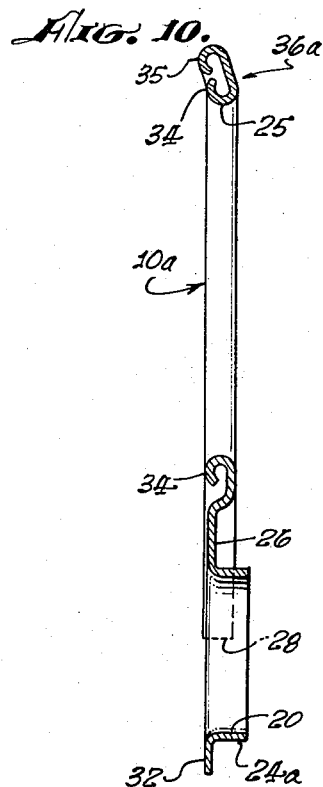
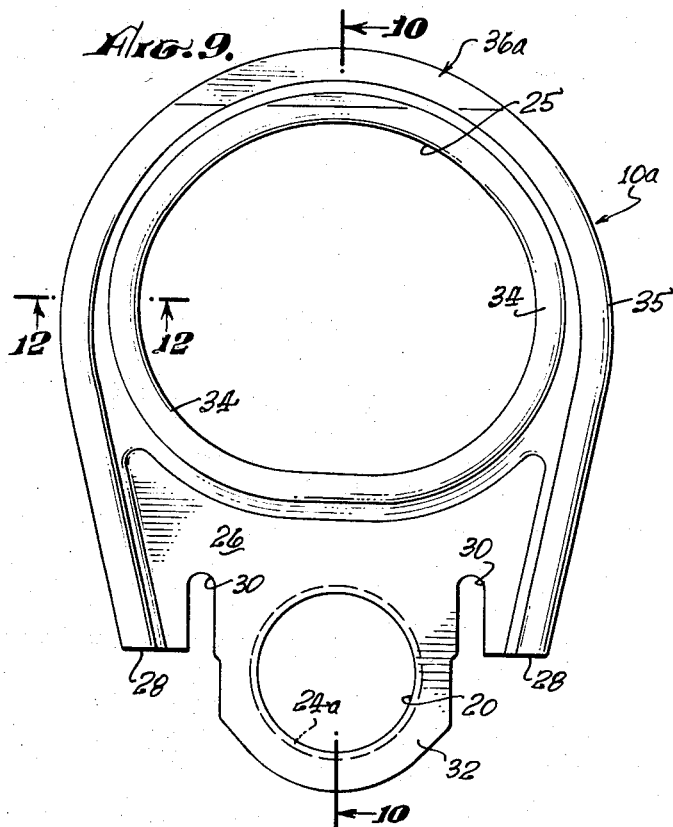

DONALD B. PETERS,  
OMAR L. BROWN,  
INVENTORS.

BY  
Smyth, Roston & Pavitt  
ATTORNEYS.

3,349,949  
**RING-SHAPED TAB FOR TEAR STRIPS  
 OF CONTAINERS**

Omar L. Brown and Don B. Peters, Dayton, Ohio, assignors, by mesne assignments, to Ermal C. Frazee, Dayton, Ohio

Filed July 6, 1965, Ser. No. 469,584  
 14 Claims. (Cl. 220—54)

This invention relates to a container having a portion of its wall weakened to serve as a tear strip and, more particularly, relates to the structure of a tab that is attached to the tear strip to serve as manual means for severing the tear strip. The invention is directed primarily to the problem of so constructing such a tab as to facilitate effective finger engagement with the tab for the purpose of carrying out the severance operation.

One reason for constructing a tab for effective manual engagement is that once severance is initiated at the leading end of the tear strip, the tab is used as a handle to exert substantial pulling force on the tear strip to continue the severance operation. A much more important reason, however, relates to the hazardous effect of internal fluid pressure on the tear strip and on the tab when a container confining a carbonated beverage is initially ruptured.

When the severance of the leading end of the tear strip is initiated by manipulation of the tab, the static pressure of a confined fluid is against the under surface of the tear strip and, if the tab is at a relatively low angle when the severance is initiated, the dynamic pressure of the high velocity stream of released fluid is simultaneously directed against the underside of the tab itself. Consequently the combination of static and dynamic pressure against the tear strip and tab respectively may abruptly sever the whole tear strip and yank the tab free from the operator's fingers, the tear strip and the attached tab being projected away from the container at a dangerously high velocity. There is good reason, therefore, to promote effective gripping of the tab by the user.

Since the prevalent type of tab is made of smooth sheet metal, the tab is somewhat slippery and especially so when the tab is stiffened by smooth embossed longitudinal ribs and the tab is especially slippery when moistened by the initially released fluid. Various attempts have been made to remedy this situation by deforming the metal of the tab. For example, the tab may be embossed to form one or more transverse ribs for gripping by the user. As another example, the tab may be formed with numerous minute steep-sided bosses to serve as small "hobnails" to facilitate frictionally gripping of the tab by the user.

The problem is complicated by the fact that beverage cans of this type are often opened by children. A given tab may be safely controlled when manipulated by an adult, but prove hazardous when frictionally gripped by the smaller and weaker fingers of children.

The present invention meets this problem by providing a relatively large aperture in the tab to give the tab a ring-like configuration. Such a ring-like configuration provides an inner circumferential edge that may be positively engaged by the thumb and forefinger of an adult to insure safe manual control of the tab in opposition to the effects of fluid pressure on the tab. The ring-shaped tab has only a small area to be subjected to dynamic fluid pressure and more likely than not any fluid stream that escapes under the tab will be directed through rather than against the ring configuration. A special advantage, moreover, is that when a child attempts to manipulate the tab it is natural for the child to hook a finger through the ring-like portion of the tab. In this manner a child engages the tab in a positive manner to keep the tab under effective manual control.

The problem to be met in carrying out this concept is that a sheet metal tab must be stiff to serve effectively as a lever for prying action and the weakening of the tab by removal of material to provide the ring-shape is contrary to this requirement. This problem is met by turning or rolling the inner and outer edges of the apertured tab to provide inner and outer stiffening beads or flanges. Fortunately the inner stiffening bead provides a thickened inner circumferential edge for the ring-like portion to facilitate manual engagement with the tab and to avoid sharp metal edges.

The inner stiffening bead preferably is continuous around the inner circumference of the ring-shaped portion of the tab and for the extent of its dimension lends longitudinal stiffness to the tab. The outer peripheral stiffening bead has a central portion that extends around at least half of the circumference of the ring-shaped portion of the tab and has two end portions that extend tangentially from opposite sides of the ring-shaped portion to serve as further means for longitudinally stiffening the tab.

In the presently preferred embodiment of the invention, the tab has a lever portion and a contiguous end portion that is connected to the tear strip, the lever portion being of forked configuration with two fulcrum ends straddling the end portion of the tab that is attached to the tear strip. The two ends of the outer peripheral stiffening bead extend to the ends of the two fulcrum ends respectively of the lever to stiffen the fulcrum ends as well as to stiffen the whole length of the lever. As will be explained, a feature of the invention in this regard is that in the region of the two fulcrum ends of the lever, the peripheral stiffening bead is formed by turning or rolling the sheet metal into abutment with its surface for a highly advantageous stiffening effect.

The features and advantages of the invention may be understood from the following detailed description and the accompanying drawings.

In the drawings, which are to be regarded as merely illustrative:

FIG. 1 is a plan view of the presently preferred embodiment of the tab;

FIG. 2 is a longitudinal section of the tab taken along the line 2—2 of FIG. 1;

FIG. 3 is a fragmentary section of the tab on an enlarged scale taken as indicated by the angular line 3—3 of FIG. 1;

FIG. 4 is an end elevation of the tab;

FIG. 5 is an enlarged fragmentary section taken along the angular line 5—5 of FIG. 1;

FIG. 6 is an enlarged radial section of the ring-shaped portion of the tab taken as indicated by the line 6—6 of FIG. 1;

FIG. 7 is a plan view on a small scale of a can top incorporating the first embodiment of the invention;

FIG. 8 is a section along the line 8—8 of FIG. 7 showing how the preferred embodiment of the tab is installed in engagement with a hollow rivet formed in the tear strip;

FIG. 9 is a plan view of a second embodiment of the tab;

FIG. 10 is a longitudinal section along the line 10—10 of FIG. 9;

FIG. 11 is an end elevation of the same tab;

FIG. 12 is an enlarged radial section along the line 12—12 of FIG. 9;

FIG. 13 is a plan view similar to FIG. 7 showing a can top incorporating the second embodiment of the tab; and

FIG. 14 is a diametrical section of the can top along the line 14—14 of FIG. 13.

FIG. 1 shows the presently preferred embodiment of the tab, generally designated 10, in top plan view; FIGS.

2, 3, 5 and 6 show various sections of the tab; and FIGS. 7 and 8 show the tab 10 mounted on a top wall 12 of a can.

Referring first to FIGS. 7 and 8, the top wall 12 of the can is formed with a peripheral flange 14 for attachment to the cylindrical body of a can (not shown). A tear strip 15 is formed in the can top 12 by a line of scoring 16 and, as best shown in FIG. 12, a hollow rivet 18 formed in the metal of the tear strip extends through an aperture 20 in the tab 10 for connecting the tab to the tear strip. In a well known manner, the hollow rivet is formed with a head or peripheral bead 22 in overhanging engagement with the rim of the aperture 20. Preferably the rim of the aperture 20 is formed with a flange 24 which snugly embraces the hollow rivet 18 below the bead 22.

The tab 10 is preferably made of sheet material and the tab has a relatively large aperture 25 by virtue which the major portion of the tab is of the configuration of a ring. A web 26 of the sheet metal extends laterally from the ring and is formed with the previously mentioned aperture 20 for engagement with the rivet 18. It is to be understood, however, that the web 26 may be attached to a tear strip in various ways in various practices of the invention and therefore the tab is not necessarily formed with the aperture 20.

The ring-shaped tab 10 may be adapted in any suitable manner to initiate severance of the leading end of the tear strip 15 to which it is attached. In this particular embodiment of the invention, the tab 10 functions as a lever to tilt the hollow rivet 18 by fulcrum action against the wall 12 of the can top. For this purpose the tab 10 is preferably shaped to provide what may be termed a forked lever which is attached to the tab by the web 26 and which has two fulcrum ends 28 which straddle the rivet-engaging aperture 20. In the construction shown the fulcrum ends 28 are formed by providing two slots 30 which extend inwardly from the edge of the web and thus define a central portion 32 of the web to which the hollow rivet is attached.

It is contemplated that the sheet metal of the tab 10 will be suitably embossed, rolled or otherwise strengthened to make the forked lever sufficiently stiff for effective lever action. In the construction shown, the rim of the relatively large aperture 25 is turned towards the underside of the tab to form a first inner stiffening bead or flange 34, which as best shown in the second embodiment in FIG. 9 is continuous around the entire inner circumference of the ring. In like manner the outer peripheral edge of the sheet metal is turned under towards the underside of the tab to form a second outer stiffening flange or bead 35 which, as best shown in FIG. 9 is of the general configuration of a horseshoe. It can be seen that the central portion of the horseshoe-shaped stiffening bead 35 extends around approximately half of the circumference of the inner stiffening bead 34 concentrically thereof and that the two ends of the outer stiffening bead extend tangentially from the ring to the ends of the two fulcrum ends 28, respectively.

Preferably the sheet metal is rolled or turned to C-shaped configuration to form the inner and outer stiffening beads 35 and 34. Consequently, where the two beads 35 and 34 are close together around half of the circumference of the large aperture 25, the two beads cooperate to form a downwardly facing channel with overhanging side walls, the configuration of the channel being shown in FIG. 6. It is apparent that the ring-shaped portion of the tab is of hollow configuration in radial cross section and that the two fulcrum ends 28 are also of hollow configuration with the hollow configurations of the two fulcrum ends continuous with the hollow configuration of the ring.

By virtue of the two curled stiffening beads 34 and 35, the tab has no exposed raw metal edges in the region where the tab is manually grasped. The inner stiffening

beads 34 has special utility in providing a relatively thick smooth rounded surface to receive finger pressure for pulling on the tab after initial severance of the tear strip is accomplished.

When the lever is operated by swinging the tab outward from the can top with consequent bending of central portion 32 of the web 26, the stressing of the lever is concentrated in the two fulcrum ends 28. In this regard a feature of the invention is that in each of the two end portions of the outer stiffening bead 35 that extend along a fulcrum end 28, the sheet material of the outer bead is closed, i.e. the sheet material of the outer bead is rolled against itself with the rolled edge of the sheet material in edgewise abutment with the surface of the sheet material for reinforcement of the sheet material by the abutting edge as may be seen in FIGS. 3 and 4. It has been found that reinforcement of the two fulcrum ends 28 in this manner insures adequate strength for the two fulcrum ends when the lever action is carried out to initiate severance of the tear strip.

As shown in FIGS. 3 and 4, the plane of the web 26 is preferably at the level of the underside of the ring portion of the tab and therefore when the tab is mounted on a tear strip in the manner shown in FIG. 8, the downwardly turned flange 24 of the tab causes the lever that is formed by the tab to be spaced appreciably above the wall 12 of the can top. The advantage of providing this spacing is that the tab is initially swung outward through an appreciable angle before the leverage action is initiated by contact of the fulcrum ends 28 against the wall 12 of the can top, the relatively high angle of the lever facilitating the application of manual force to the lever. Preferably, the outer end of the ring-shaped tab is bent upward as indicated at 36 in FIG. 2 to facilitate initial lifting of the tab, the two stiffening beads 34 and 35 being flattened together as shown.

It is apparent that the thick inner circumferential rim of the ring-shaped tab promotes effective gripping of the tab by an adult. It is also apparent that if a child operates the tab, the child will naturally hook a finger through the large aperture of the tab to insure safe manual retention of the tab. A further advantage is that a ring-shaped tab has a relatively small area against which the dynamic pressure of an escaping fluid stream may act.

The second embodiment of the invention shown in FIGS. 9-14 is largely identical with the first embodiment as indicated by the use of corresponding numerals to indicate corresponding parts. Only three differences are involved. The first difference is that the ring-shaped tab 10a is turned upside down relative to the position of the tab in the first embodiment of the invention, the inner and outer stiffening ribs 34 and 35 being on the upper side of the tab instead of on the lower side. The second difference is that the flange 24a of the tab is also reversed so that the flange 24a, like the flange 24, is directed downward towards the can top wall 15. The third difference is that the upwardly bent portion 36a at the outer end of the tab (FIG. 10) is not flattened to the same extent as the portion 36 of the first embodiment.

Our description in specific detail of the selected embodiments of the invention will suggest various changes, substitutions and other departures from our disclosure within the spirit and scope of the appended claims.

We claim:

1. A tab for attachment to a tear strip in a wall of a container for manual removal of the tear strip, comprising:
  - a one-piece member of sheet material having a relatively large aperture forming a portion of the member into a ring-like configuration to serve as a handle for manipulating the member,
  - said member having an extending portion for attachment to the tear strip,
  - inner and outer edges of said member being turned to form stiffening inner and outer beads extending

5

6

around at least half of the circumference of the ring-like portion of the member,  
said inner bead being continuous around the inner circumference of the ring-like portion of the member, the outer bead having two ends extending from opposite sides of the ring-like portion of the member along opposite sides of said extending portion to stiffen the member longitudinally.

2. A tab as set forth in claim 1 in which the sheet material forming each of the two ends of the outer bead is rolled against itself with the rolled edge of the sheet material in edgewise abutment with the surface of the sheet material for reinforcement of the sheet material by the abutting edge.

3. A tab for attachment to a tear strip in a wall of a container for manual removal of the tear strip, comprising:

a one-piece member of sheet material having a relatively large aperture forming a portion of the member into a ring-like configuration to serve as a handle for manipulating the tab, said ring-like portion being of hollow radial cross-sectional configuration for stiffness,

said member having a web extending radially from the ring-like portion for attachment to the tear strip, said web being slotted to form a bendable central web portion for attachment to the tear strip and to form two fulcrum ends straddling the central web portion to fulcrum against the wall of the container to exert lifting force on the central web portion to initiate severance of the tear strip,

longitudinal edges of the sheet material of said fulcrum ends being turned for stiffness.

4. A tab as set forth in claim 3 in which said fulcrum ends extend substantially tangentially from the ring-like portion and are of hollow cross-sectional configuration continuous with the hollow cross-sectional configuration of the ring-like portion of the member.

5. A tab as set forth in claim 3 in which said web has an aperture therein, said last mentioned aperture being formed with a continuous flange to serve as a collar to embrace a hollow rivet formed in the tear strip for attachment of the member to the tear strip.

6. A tab for attachment to a tear strip in a wall of a container for manual removal of the tear strip, comprising:

a one-piece member of sheet material having a relatively large aperture forming a portion of the member into a ring-like configuration to serve as a handle for manipulating the member,

the rim of said aperture being turned to provide a first inner stiffening bead and to provide a smooth inner circumferential surface for the ring-like portion,

said member having a web extending radially from the ring-like portion for attachment to the tear strip, said web being slotted to form a bendable central web portion for attachment to the tear strip and to form two fulcrum ends straddling the central web portion to fulcrum against the wall of the container to exert lifting force on the central web portion to initiate severance of the tear strip,

the periphery of said member being turned to provide a second outer stiffening bead and to provide a smooth outer edge surface for the member,

said second stiffening bead being of generally horse-shoe-shaped in plan with its mid portion straddling the first stiffening bead in close radial spacing therefrom and with its ends extending along said two fulcrum ends to stiffen the fulcrum ends.

7. A tab as set forth in claim 6 in which the inner and outer edges of the member are turned towards each other to form a stiffening channel with overhanging side walls along the mid portion of the second bead.

8. A tab for attachment to a tear strip of a container

to serve as means for manually severing the tear strip, said tab comprising:

a member of deformable sheet material,

said member having a relatively large aperture forming a ring-like portion of the member to serve as a handle,

said member having a bendable web portion extending radially from the ring-like portion for attachment to the leading end of the tear strip,

said member having slots extending inward from its edge on the opposite sides of said bendable web portion with the slots forming two fulcrum ends straddling the bendable web portion to act against the surface of the container to initiate severance of the tear strip,

the sheet material of said member being turned to provide a first stiffening bead along the inner circumference of the ring-like portion and to provide a second stiffening bead along the outer circumference of the ring-like portion,

said second bead having opposite end portions extending generally tangentially from the ring-like portion to said fulcrum ends.

9. A tab as set forth in claim 8 in which the sheet material forming each of said end portions of the second bead is rolled against itself with the rolled edge of the sheet material in edgewise abutment with the surface of the sheet material for reinforcement of the sheet material by the abutting edge.

10. A tab of the character described comprising a piece of sheet material having a relatively large handle portion and a narrower relatively small adjacent attachment portion for attachment of the tab to a tear strip in a wall of the container whereby the tab may serve as manual means to at least partially remove the tear strip for access to the interior of the container,

said handle portion of the tab having a relatively large aperture therein forming the handle portion into a ring-like element for engagement by the finger of a user,

the rim of the relatively large aperture being turned to provide a smooth inner circumferential surface for the ring-like element and to form a continuous inner bead around the inner circumference of the ring-like element to lend stiffness to the tab,

the outer marginal portion of the tab being turned to form an outer bead to lend further stiffness to the tab,

an intermediate portion of said outer bead extending around at least 180° of the periphery of the ring-like element with the two end portions of the outer bead extending generally tangentially away from said intermediate portion of the outer bead along opposite sides of said attachment portion to lend further stiffness to the tab,

said intermediate portion of the outer bead and the corresponding portion of the inner bead being close together with the sheet material of the two beads turned towards each other.

11. A tab as set forth in claim 10 in which both of said beads are turned towards each other on one of the upper and lower faces of the tab with the surface of the ring-like element split on said one of the upper and lower faces of the tab in the region of said intermediate portion of the outer bead and with the surface of the ring-like element continuous across the radius of the ring-like element in said region on the other of said upper and lower faces of the tab.

12. A tab as set forth in claim 11 in which said beads are turned towards the under face of the tab in said region with the surface of the ring-like element split across the radius of the ring-like element on the under face of the tab in said region and continuous on the upper face of the tab in said region.

7

13. A tab as set forth in claim 12 in which said attachment portion of the tab is offset downward from the upper surface of the ring-like element to lie contiguous to said wall of the container.

14. A tab as set forth in claim 10 in which said attachment portion of the tab is formed with a relatively small aperture to facilitate attachment of the tab to the tear strip.

8

References Cited

UNITED STATES PATENTS

3,084,835	4/1963	Walsh	-----	220—54
3,215,306	11/1965	Simpson et al.	-----	220—54
3,221,924	12/1965	Harvey et al.	-----	220—54

THERON E. CONDON, *Primary Examiner.*

G. T. HALL, *Assistant Examiner.*