



US010245485B2

(12) **United States Patent**
Burnett et al.

(10) **Patent No.:** **US 10,245,485 B2**

(45) **Date of Patent:** ***Apr. 2, 2019**

(54) **GOLF CLUB HEAD HAVING A STRESS REDUCING FEATURE WITH APERTURE**

(71) Applicant: **Taylor Made Golf Company, Inc.**,
Carlsbad, CA (US)

(72) Inventors: **Michael Scott Burnett**, McKinney, TX (US); **Bryan Seon**, Garland, TX (US); **Jeffrey T. Halstead**, Plano, TX (US); **Justin Girard**, Dallas, TX (US)

(73) Assignee: **Taylor Made Golf Company Inc.**,
Carlsbad, CA (US)

(*) Notice: Subject to any disclaimer, the term of this patent is extended or adjusted under 35 U.S.C. 154(b) by 0 days.

This patent is subject to a terminal disclaimer.

(21) Appl. No.: **15/957,961**

(22) Filed: **Apr. 20, 2018**

(65) **Prior Publication Data**

US 2018/0236319 A1 Aug. 23, 2018

Related U.S. Application Data

(63) Continuation of application No. 15/437,835, filed on Feb. 21, 2017, now Pat. No. 9,950,223, which is a continuation of application No. 14/868,446, filed on Sep. 29, 2015, now Pat. No. 9,610,482, which is a continuation of application No. 14/472,415, filed on (Continued)

(51) **Int. Cl.**

A63B 53/04 (2015.01)
A63B 60/52 (2015.01)
A63B 60/48 (2015.01)
A63B 60/50 (2015.01)

(52) **U.S. Cl.**

CPC *A63B 53/0475* (2013.01); *A63B 53/04* (2013.01); *A63B 53/0466* (2013.01); *A63B 60/52* (2015.10); *A63B 60/48* (2015.10); *A63B 60/50* (2015.10); *A63B 2053/0408* (2013.01); *A63B 2053/0412* (2013.01);

(Continued)

(58) **Field of Classification Search**

USPC 473/324–350
See application file for complete search history.

(56) **References Cited**

U.S. PATENT DOCUMENTS

411,000 A 9/1889 Anderson
708,575 A 9/1902 Mules
(Continued)

FOREIGN PATENT DOCUMENTS

CN 2436182 Y 6/2001
CN 201353407 Y 12/2009
(Continued)

OTHER PUBLICATIONS

“Cleveland HiBore Driver Review,” <http://thesandtrip.com>, 7 pages, May 19, 2006.

(Continued)

Primary Examiner — Alvin Hunter

(74) *Attorney, Agent, or Firm* — Dawsey Co., LPA;
David J. Dawsey

(57) **ABSTRACT**

A golf club incorporating a stress reducing feature, including an aperture, located at least partially on the sole of the club head. The location and size of the stress reducing feature and aperture, and their relationship to one another, play a significant role in selectively improving the performance of the golf club.

20 Claims, 28 Drawing Sheets

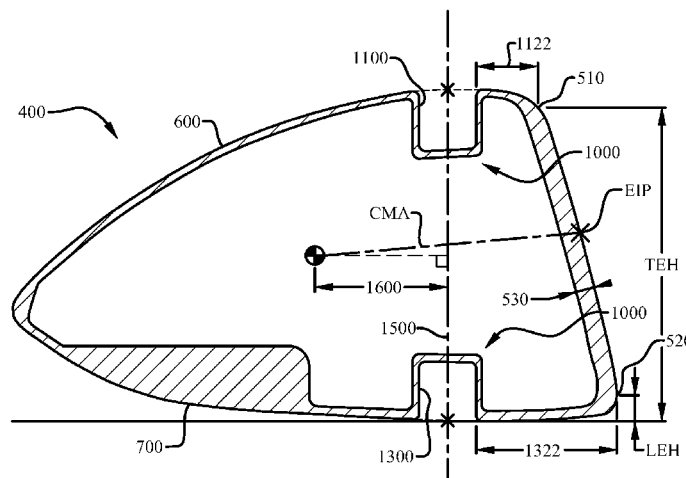

Related U.S. Application Data

Aug. 29, 2014, now Pat. No. 9,168,434, which is a continuation of application No. 13/397,122, filed on Feb. 15, 2012, now Pat. No. 8,821,312, which is a continuation-in-part of application No. 12/791,025, filed on Jun. 1, 2010, now Pat. No. 8,235,844.

- (52) **U.S. Cl.**
 CPC *A63B 2053/0433* (2013.01); *A63B 2053/0437* (2013.01); *A63B 2053/0458* (2013.01)

(56) **References Cited**

U.S. PATENT DOCUMENTS

727,819 A 5/1903 Mattern
 819,900 A 5/1906 Martin
 1,133,129 A 3/1915 Govan
 1,518,316 A 12/1924 Ellingham
 1,526,438 A 2/1925 Scott
 1,538,312 A 5/1925 Beat
 1,592,463 A 7/1926 Marker
 1,658,581 A 2/1928 Tobia
 1,704,119 A 3/1929 Buhrke
 1,705,997 A 3/1929 Williams
 1,970,409 A 8/1934 Wiedemann
 2,004,968 A 6/1935 Young
 2,034,936 A 3/1936 Barnhart
 2,041,676 A 5/1936 Gallagher
 D107,007 S 11/1937 Cashmore
 2,198,981 A 4/1940 Sullivan
 2,214,356 A 9/1940 Wettlaufer
 2,225,930 A 12/1940 Sexton
 2,328,583 A 9/1943 Reach
 2,332,342 A 10/1943 Reach
 2,360,364 A 10/1944 Reach
 2,375,249 A 5/1945 Richer
 2,460,435 A 2/1949 Schaffer
 2,681,523 A 6/1954 Sellers
 2,968,486 A 1/1961 Jackson
 3,064,980 A 11/1962 Steiner
 3,084,940 A 4/1963 Cissel
 3,085,804 A 4/1963 Pieper
 3,166,320 A 1/1965 Onions
 3,466,047 A 9/1969 Rodia et al.
 3,486,755 A 12/1969 Hodge
 3,556,533 A 1/1971 Hollis
 3,589,731 A 6/1971 Chancellor
 3,606,327 A 9/1971 Gorman
 3,610,630 A 10/1971 Glover
 3,652,094 A 3/1972 Glover
 3,672,419 A 6/1972 Fischer
 3,692,306 A 9/1972 Glover
 3,743,297 A 7/1973 Dennis
 3,860,244 A 1/1975 Cosby
 3,893,672 A 7/1975 Schonher
 3,897,066 A 7/1975 Belmont
 3,970,236 A 7/1976 Rogers
 3,976,299 A 8/1976 Lawrence et al.
 3,979,122 A 9/1976 Belmont
 3,979,123 A 9/1976 Belmont
 3,985,363 A 10/1976 Jepson et al.
 3,997,170 A 12/1976 Goldberg
 4,008,896 A 2/1977 Gordos
 4,027,885 A 6/1977 Rogers
 4,043,563 A 8/1977 Churchward
 4,052,075 A 10/1977 Daly
 4,065,133 A 12/1977 Gordos
 4,076,254 A 2/1978 Nygren
 4,077,633 A 3/1978 Studen
 4,085,934 A 4/1978 Churchward
 4,121,832 A 10/1978 Ebbing
 4,139,196 A 2/1979 Riley
 4,147,349 A 4/1979 Jeghers
 4,150,702 A 4/1979 Holmes

4,165,076 A 8/1979 Cella
 4,189,976 A 2/1980 Becker
 4,193,601 A 3/1980 Reid, Jr. et al.
 4,214,754 A 7/1980 Zebelean
 D256,709 S 9/1980 Reid, Jr. et al.
 4,247,105 A 1/1981 Jeghers
 4,262,562 A 4/1981 MacNeill
 D259,698 S 6/1981 MacNeill
 4,322,083 A 3/1982 Imai
 4,340,229 A 7/1982 Stuff, Jr.
 4,398,965 A 8/1983 Campau
 4,411,430 A 10/1983 Dian
 4,423,874 A 1/1984 Stuff, Jr.
 4,431,192 A 2/1984 Stuff, Jr.
 4,432,549 A 2/1984 Zebelean
 4,438,931 A 3/1984 Motomiya
 4,471,961 A 9/1984 Masghati et al.
 4,489,945 A 12/1984 Kobayashi
 4,527,799 A 7/1985 Solheim
 4,530,505 A 7/1985 Stuff
 D284,346 S 6/1986 Masters
 4,592,552 A 6/1986 Garber
 4,602,787 A 7/1986 Sugioka et al.
 4,607,846 A 8/1986 Perkins
 D285,473 S 9/1986 Flood
 4,712,798 A 12/1987 Preato
 4,730,830 A 3/1988 Tilley
 4,736,093 A 4/1988 Braly
 4,754,974 A 7/1988 Kobayashi
 4,754,977 A 7/1988 Sahn
 4,762,322 A 8/1988 Molitor et al.
 4,787,636 A 11/1988 Honma
 4,795,159 A 1/1989 Nagamoto
 4,803,023 A 2/1989 Enomoto et al.
 4,809,983 A 3/1989 Langert
 4,867,457 A 9/1989 Lowe
 4,867,458 A 9/1989 Sumikawa et al.
 4,869,507 A 9/1989 Sahn
 4,881,739 A 11/1989 Garcia
 4,890,840 A 1/1990 Kobayashi
 4,895,367 A 1/1990 Kajita et al.
 4,895,371 A 1/1990 Bushner
 4,915,558 A 4/1990 Muller
 4,919,428 A 4/1990 Perkins
 D307,783 S 5/1990 Iinuma
 4,962,932 A 10/1990 Anderson
 4,994,515 A 2/1991 Washiyama et al.
 5,006,023 A 4/1991 Kaplan
 5,020,950 A 6/1991 Ladouceur
 5,028,049 A 7/1991 McKeighen
 5,039,267 A 8/1991 Wollar
 5,042,806 A 8/1991 Helmstetter
 5,050,879 A 9/1991 Sun et al.
 5,058,895 A 10/1991 Igarashi
 5,076,585 A 12/1991 Bouquet
 D323,035 S 1/1992 Yang
 5,078,400 A 1/1992 Desbiolles et al.
 5,092,599 A 3/1992 Okumoto et al.
 5,116,054 A 5/1992 Johnson
 5,121,922 A 6/1992 Harsh, Sr.
 5,122,020 A 6/1992 Bedi
 5,172,913 A 12/1992 Bouquet
 5,190,289 A 3/1993 Nagai et al.
 5,193,810 A 3/1993 Antonious
 5,203,565 A 4/1993 Murray et al.
 5,221,086 A 6/1993 Antonious
 5,232,224 A 8/1993 Zeider
 5,244,210 A 9/1993 Au
 5,251,901 A 10/1993 Solheim et al.
 5,253,869 A 10/1993 Dingle et al.
 5,255,919 A 10/1993 Johnson
 D343,558 S 1/1994 Latraverse et al.
 5,297,794 A 3/1994 Lu
 5,301,944 A 4/1994 Koehler
 5,306,008 A 4/1994 Kinoshita
 5,316,305 A 5/1994 McCabe
 5,318,297 A 6/1994 Davis et al.
 5,320,005 A 6/1994 Hsiao
 5,328,176 A 7/1994 Lo

(56)

References Cited

U.S. PATENT DOCUMENTS

5,340,106	A	8/1994	Ravaris	RE35,955	E	11/1998	Lu
5,346,216	A	9/1994	Aizawa	5,830,084	A	11/1998	Kosmatka
5,346,217	A	9/1994	Tsuchiya et al.	D402,726	S	12/1998	McCabe et al.
D351,441	S	10/1994	Iinuma et al.	D403,037	S	12/1998	Stone et al.
5,385,348	A	1/1995	Wargo	5,851,160	A	12/1998	Rugge et al.
5,395,113	A	3/1995	Antonious	D405,488	S	2/1999	Burrows
D357,290	S	4/1995	Viollaz et al.	5,876,293	A	3/1999	Musty
5,410,798	A	5/1995	Lo	5,885,166	A	3/1999	Shiraishi
5,419,556	A	5/1995	Take	5,890,971	A	4/1999	Shiraishi
5,421,577	A	6/1995	Kobayashi	D409,463	S	5/1999	McMullin
5,429,365	A	7/1995	McKeighen	5,908,356	A	6/1999	Nagamoto
5,437,456	A	8/1995	Schmidt et al.	5,911,638	A	6/1999	Parente et al.
5,439,222	A	8/1995	Kranenberg	5,913,735	A	6/1999	Kenmi
5,441,274	A	8/1995	Clay	5,916,042	A	6/1999	Reimers
5,447,309	A	9/1995	Vincent	D412,547	S	8/1999	Fong
5,449,260	A	9/1995	Whittle	5,935,019	A	8/1999	Yamamoto
D363,750	S	10/1995	Reed	5,935,020	A	8/1999	Stites et al.
D365,615	S	12/1995	Shimatani	5,941,782	A	8/1999	Cook
D366,508	S	1/1996	Lutin	D413,952	S	9/1999	Oyer
5,482,280	A	1/1996	Yamawaki	5,947,840	A	9/1999	Ryan
5,484,155	A	1/1996	Yamawaki et al.	5,954,595	A	9/1999	Antonious
5,492,327	A	2/1996	Biafore, Jr.	5,967,905	A	10/1999	Nakahara et al.
5,511,786	A	4/1996	Antonious	5,971,867	A	10/1999	Galy
5,518,243	A	5/1996	Redman	5,976,033	A	11/1999	Takeda
5,533,730	A	7/1996	Ruvang	5,997,415	A	12/1999	Wood
D372,512	S	8/1996	Simmons	6,001,029	A	12/1999	Kobayashi
5,544,884	A	8/1996	Hardman	6,007,433	A	12/1999	Helmstetter et al.
5,547,188	A	8/1996	Dumontier et al.	6,015,354	A	1/2000	Ahn et al.
5,558,332	A	9/1996	Cook	6,017,177	A	1/2000	Lanham
D375,130	S	10/1996	Hlinka et al.	6,019,686	A	2/2000	Gray
5,564,705	A	10/1996	Kobayashi et al.	6,023,891	A	2/2000	Robertson et al.
5,571,053	A	11/1996	Lane	6,032,677	A	3/2000	Blechman et al.
5,573,467	A	11/1996	Chou et al.	6,033,318	A	3/2000	Drajan, Jr. et al.
5,575,723	A	11/1996	Take et al.	6,033,319	A	3/2000	Farrar
5,582,553	A	12/1996	Ashcraft et al.	6,033,321	A	3/2000	Yamamoto
D377,509	S	1/1997	Katayama	6,042,486	A	3/2000	Gallagher
5,613,917	A	3/1997	Kobayashi et al.	6,048,278	A	4/2000	Meyer et al.
D378,770	S	4/1997	Hlinka et al.	6,056,649	A	5/2000	Imai
5,616,088	A	4/1997	Aizawa et al.	6,062,988	A	5/2000	Yamamoto
5,620,379	A	4/1997	Borys	6,074,308	A	6/2000	Domas
5,624,331	A	4/1997	Lo et al.	6,077,171	A	6/2000	Yoneyama
5,629,475	A	5/1997	Chastonay	6,083,115	A	7/2000	King
5,632,694	A	5/1997	Lee	6,086,485	A	7/2000	Hamada et al.
5,632,695	A	5/1997	Hlinka et al.	6,089,994	A	7/2000	Sun
D382,612	S	8/1997	Oyer	6,093,113	A	7/2000	Mertens
5,658,206	A	8/1997	Antonious	6,123,627	A	9/2000	Antonious
5,669,827	A	9/1997	Nagamoto	6,139,445	A	10/2000	Werner et al.
5,681,228	A	10/1997	Mikame et al.	6,146,286	A	11/2000	Masuda
5,683,309	A	11/1997	Reimers	6,149,533	A	11/2000	Finn
5,688,189	A	11/1997	Bland	6,162,132	A	12/2000	Yoneyama
5,695,412	A	12/1997	Cook	6,162,133	A	12/2000	Peterson
5,700,208	A	12/1997	Nelms	6,168,537	B1	1/2001	Ezawa
5,709,613	A	1/1998	Sheraw	6,171,204	B1	1/2001	Starry
5,718,641	A	2/1998	Lin	6,186,905	B1	2/2001	Kosmatka
5,720,674	A	2/1998	Galy	6,190,267	B1	2/2001	Marlowe et al.
D392,354	S	3/1998	Burrows	6,193,614	B1	2/2001	Sasamoto et al.
D392,526	S	3/1998	Nicely	6,203,448	B1	3/2001	Yamamoto
5,735,754	A	4/1998	Antonious	6,206,789	B1	3/2001	Takeda
D394,688	S	5/1998	Fox	6,206,790	B1	3/2001	Kubica et al.
5,746,664	A	5/1998	Reynolds, Jr.	6,210,290	B1	4/2001	Erickson et al.
5,749,795	A	5/1998	Schmidt et al.	6,217,461	B1	4/2001	Galy
5,755,627	A	5/1998	Yamazaki et al.	6,238,303	B1	5/2001	Fite
5,759,114	A	6/1998	Bluto et al.	6,244,974	B1	6/2001	Hanberry, Jr.
5,762,567	A	6/1998	Antonious	6,244,976	B1	6/2001	Murphy et al.
5,766,095	A	6/1998	Antonious	6,248,025	B1	6/2001	Murphey et al.
5,769,737	A	6/1998	Holladay et al.	6,254,494	B1	7/2001	Hasebe et al.
5,772,527	A	6/1998	Liu	6,264,414	B1	7/2001	Hartmann et al.
5,776,010	A	7/1998	Helmstetter et al.	6,270,422	B1	8/2001	Fisher
5,776,011	A	7/1998	Su et al.	6,277,032	B1	8/2001	Smith
5,785,608	A	7/1998	Collins	6,290,609	B1	9/2001	Takeda
5,785,609	A	7/1998	Sheets et al.	6,296,579	B1	10/2001	Robinson
5,788,587	A	8/1998	Tseng	6,299,547	B1	10/2001	Kosmatka
5,797,807	A	8/1998	Moore	6,306,048	B1	10/2001	McCabe et al.
5,798,587	A	8/1998	Lee	6,319,149	B1	11/2001	Lee
D397,750	S	9/1998	Frazetta	6,319,150	B1	11/2001	Werner et al.
				6,325,728	B1	12/2001	Helmstetter et al.
				6,332,847	B2	12/2001	Murphy et al.
				6,334,817	B1	1/2002	Ezawa et al.
				6,334,818	B1	1/2002	Cameron et al.

(56)

References Cited

U.S. PATENT DOCUMENTS

6,338,683	B1	1/2002	Kosmatka	6,648,773	B1	11/2003	Evans
6,340,337	B2	1/2002	Hasebe et al.	6,652,387	B2	11/2003	Liberatore
6,344,000	B1	2/2002	Hamada et al.	D484,208	S	12/2003	Burrows
6,344,001	B1	2/2002	Hamada et al.	6,663,504	B2	12/2003	Hocknell et al.
6,344,002	B1	2/2002	Kajita	6,663,506	B2	12/2003	Nishimoto et al.
6,348,012	B1	2/2002	Erickson et al.	6,669,571	B1	12/2003	Cameron et al.
6,348,013	B1	2/2002	Kosmatka	6,669,576	B1	12/2003	Rice
6,348,014	B1	2/2002	Chiu	6,669,577	B1	12/2003	Hocknell et al.
6,354,962	B1	3/2002	Galloway et al.	6,669,578	B1	12/2003	Evans
6,364,788	B1	4/2002	Helmstetter et al.	6,669,580	B1	12/2003	Cackett et al.
6,368,232	B1	4/2002	Hamada et al.	6,676,536	B1	1/2004	Jacobson
6,368,234	B1	4/2002	Galloway	6,679,786	B2	1/2004	McCabe
6,371,868	B1	4/2002	Galloway et al.	D486,542	S	2/2004	Burrows
6,379,264	B1	4/2002	Forzano	6,695,712	B1	2/2004	Iwata et al.
6,379,265	B1	4/2002	Hirakawa et al.	6,716,111	B2	4/2004	Liberatore
6,383,090	B1	5/2002	Odoherly et al.	6,716,114	B2	4/2004	Nishio
6,386,987	B1	5/2002	Lejeune, Jr.	6,719,510	B2	4/2004	Cobzaru
6,386,990	B1	5/2002	Reyes et al.	6,719,641	B2	4/2004	Dabbs et al.
6,390,933	B1	5/2002	Galloway et al.	6,719,645	B2	4/2004	Kouno
6,398,666	B1	6/2002	Evans et al.	6,723,002	B1	4/2004	Barlow
6,406,378	B1	6/2002	Murphy et al.	6,739,982	B2	5/2004	Murphy et al.
6,409,612	B1	6/2002	Evans et al.	6,739,983	B2	5/2004	Helmstetter et al.
6,425,832	B2	7/2002	Cackett et al.	6,743,118	B1	6/2004	Soracco
6,434,811	B1	8/2002	Helmstetter et al.	6,749,523	B1	6/2004	Forzano
6,435,977	B1	8/2002	Helmstetter et al.	6,757,572	B1	6/2004	Forest
6,436,142	B1	8/2002	Paes et al.	6,758,763	B2	7/2004	Murphy et al.
6,440,008	B2	8/2002	Murphy et al.	6,766,726	B1	7/2004	Schwarzkopf
6,440,009	B1	8/2002	Guibaud et al.	6,773,359	B1	8/2004	Lee
6,440,010	B1	8/2002	Deshmukh	6,773,360	B2	8/2004	Willett et al.
6,443,851	B1	9/2002	Liberatore	6,773,361	B1	8/2004	Lee
6,458,042	B1	10/2002	Chen	6,776,723	B2	8/2004	Bliss et al.
6,458,044	B1	10/2002	Vincent et al.	6,776,726	B2	8/2004	Sano
6,461,249	B2	10/2002	Liberatore	6,783,465	B2	8/2004	Matsunaga
6,464,598	B1	10/2002	Miller	6,800,038	B2	10/2004	Willett et al.
6,471,604	B2	10/2002	Hocknell et al.	6,800,040	B2	10/2004	Galloway et al.
6,475,101	B2	11/2002	Burrows	6,805,643	B1	10/2004	Lin
6,475,102	B2	11/2002	Helmstetter et al.	6,808,460	B2	10/2004	Namiki
6,478,692	B2	11/2002	Kosmatka	6,811,496	B2	11/2004	Wahl et al.
6,482,106	B2	11/2002	Saso	6,821,214	B2	11/2004	Rice
6,491,592	B2	12/2002	Cackett et al.	6,824,475	B2	11/2004	Burnett et al.
6,508,978	B1	1/2003	Deshmukh	6,835,145	B2	12/2004	Tsurumaki
6,514,154	B1	2/2003	Finn	D501,036	S	1/2005	Burrows
6,524,194	B2	2/2003	McCabe	D501,523	S	2/2005	Dogan et al.
6,524,197	B2	2/2003	Boone	D501,669	S	2/2005	Burrows
6,524,198	B2	2/2003	Takeda	D501,903	S	2/2005	Tanaka
6,527,649	B1	3/2003	Neher et al.	6,855,068	B2	2/2005	Antonious
6,527,650	B2	3/2003	Reyes et al.	6,860,818	B2	3/2005	Mahaffey et al.
6,530,847	B1	3/2003	Antonious	6,860,823	B2	3/2005	Lee
6,530,848	B2	3/2003	Gillig	6,860,824	B2	3/2005	Evans
6,533,679	B1	3/2003	McCabe et al.	6,863,624	B1	3/2005	Kessler
6,547,676	B2	4/2003	Cackett et al.	D504,478	S	4/2005	Burrows
6,558,273	B2	5/2003	Kobayashi et al.	6,875,124	B2	4/2005	Gilbert et al.
6,565,448	B2	5/2003	Cameron	6,875,129	B2	4/2005	Erickson et al.
6,565,452	B2	5/2003	Helmstetter et al.	6,875,130	B2	4/2005	Nishio
6,569,029	B1	5/2003	Hamburger	6,881,158	B2	4/2005	Yang et al.
6,569,040	B2	5/2003	Bradstock	6,881,159	B2	4/2005	Galloway et al.
6,572,489	B2	6/2003	Miyamoto et al.	6,887,165	B2	5/2005	Tsurumaki
6,575,845	B2	6/2003	Galloway et al.	6,890,267	B2	5/2005	Mahaffey et al.
6,582,323	B2	6/2003	Soracco et al.	D506,236	S	6/2005	Evans et al.
6,592,466	B2	7/2003	Helmstetter et al.	6,902,497	B2	6/2005	Deshmukh et al.
6,592,468	B2	7/2003	Vincent et al.	6,904,663	B2	6/2005	Willett et al.
6,602,149	B1	8/2003	Jacobson	D508,274	S	8/2005	Burrows
6,605,007	B1	8/2003	Bissonnette et al.	D508,275	S	8/2005	Burrows
6,607,452	B2	8/2003	Helmstetter et al.	6,923,734	B2	8/2005	Meyer
6,612,938	B2	9/2003	Murphy et al.	6,926,619	B2	8/2005	Helmstetter et al.
6,616,547	B2	9/2003	Vincent et al.	6,932,717	B2	8/2005	Hou et al.
6,620,056	B2	9/2003	Galloway et al.	6,960,141	B2	11/2005	Noguchi et al.
6,638,180	B2	10/2003	Tsurumaki	6,960,142	B2	11/2005	Bissonnette et al.
6,638,183	B2	10/2003	Takeda	6,964,617	B2	11/2005	Williams
D482,089	S	11/2003	Burrows	6,974,393	B2	12/2005	Caldwell et al.
D482,090	S	11/2003	Burrows	6,988,960	B2	1/2006	Mahaffey et al.
D482,420	S	11/2003	Burrows	6,991,558	B2	1/2006	Beach et al.
6,641,487	B1	11/2003	Hamburger	6,991,560	B2	1/2006	Tseng
6,641,490	B2	11/2003	Ellemor	D515,165	S	2/2006	Zimmerman et al.
6,648,772	B2	11/2003	Vincent et al.	6,994,636	B2	2/2006	Hocknell et al.
				6,994,637	B2	2/2006	Murphy et al.
				6,997,820	B2	2/2006	Willett et al.
				7,004,849	B2	2/2006	Cameron
				7,004,852	B2	2/2006	Billings

(56)

References Cited

U.S. PATENT DOCUMENTS

D518,129	S	3/2006	Poynor et al.	7,387,577	B2	6/2008	Murphy et al.
7,025,692	B2	4/2006	Erickson et al.	7,390,266	B2	6/2008	Gwon
7,029,403	B2	4/2006	Rice et al.	7,396,293	B2	7/2008	Soracco
D520,585	S	5/2006	Hasebe	7,396,296	B2	7/2008	Evans et al.
D523,104	S	6/2006	Hasebe	7,402,112	B2	7/2008	Galloway et al.
7,070,512	B2	7/2006	Nishio	7,407,447	B2	8/2008	Beach et al.
7,070,517	B2	7/2006	Cackett et al.	7,407,448	B2	8/2008	Stevens et al.
7,077,762	B2	7/2006	Kouno et al.	7,413,520	B1	8/2008	Hocknell et al.
7,082,665	B2	8/2006	Deshmukh et al.	D577,090	S	9/2008	Pergande et al.
7,094,159	B2	8/2006	Takeda	7,419,441	B2	9/2008	Hoffman et al.
7,097,572	B2	8/2006	Yabu	D579,507	S	10/2008	Llewellyn et al.
7,101,289	B2	9/2006	Gibbs et al.	7,431,667	B2	10/2008	Vincent et al.
7,112,148	B2	9/2006	Deshmukh	7,438,647	B1	10/2008	Hocknell
7,118,493	B2	10/2006	Galloway	7,438,649	B2	10/2008	Ezaki et al.
7,121,957	B2	10/2006	Hocknell et al.	7,448,963	B2	11/2008	Beach et al.
7,125,344	B2	10/2006	Hocknell et al.	7,455,598	B2	11/2008	Williams et al.
7,128,661	B2	10/2006	Soracco et al.	7,470,201	B2	12/2008	Nakahara et al.
D532,474	S	11/2006	Bennett et al.	D584,784	S	1/2009	Barez et al.
7,134,971	B2	11/2006	Franklin et al.	7,476,161	B2	1/2009	Williams et al.
7,137,905	B2	11/2006	Kohno	7,491,134	B2	2/2009	Murphy et al.
7,137,906	B2	11/2006	Tsunoda et al.	D588,223	S	3/2009	Kuan
7,137,907	B2	11/2006	Gibbs et al.	7,497,787	B2	3/2009	Murphy et al.
7,140,974	B2	11/2006	Chao et al.	7,500,924	B2	3/2009	Yokota
7,144,334	B2	12/2006	Ehlers et al.	7,520,820	B2	4/2009	Dimarco
7,147,572	B2	12/2006	Kohno	D592,723	S	5/2009	Chau et al.
7,147,573	B2	12/2006	DiMarco	7,530,901	B2	5/2009	Imamoto et al.
7,153,220	B2	12/2006	Lo	7,530,904	B2	5/2009	Beach et al.
7,156,750	B2	1/2007	Nishitani et al.	7,540,811	B2	6/2009	Beach et al.
7,163,468	B2	1/2007	Gibbs et al.	7,549,933	B2	6/2009	Kumamoto
7,163,470	B2	1/2007	Galloway et al.	7,549,935	B2	6/2009	Foster et al.
7,166,038	B2	1/2007	Williams et al.	7,563,175	B2	7/2009	Nishitani et al.
7,166,040	B2	1/2007	Hoffman et al.	7,568,985	B2	8/2009	Beach et al.
7,166,041	B2	1/2007	Evans	7,572,193	B2	8/2009	Yokota
7,169,058	B1	1/2007	Fagan	7,578,751	B2	8/2009	Williams et al.
7,169,060	B2	1/2007	Stevens et al.	7,578,753	B2	8/2009	Beach et al.
D536,402	S	2/2007	Kawami	D600,767	S	9/2009	Horacek et al.
7,179,034	B2	2/2007	Ladouceur	7,582,024	B2	9/2009	Shear
D538,866	S	3/2007	Kim et al.	7,591,737	B2	9/2009	Gibbs et al.
7,186,190	B1	3/2007	Beach et al.	7,591,738	B2	9/2009	Beach et al.
7,189,169	B2	3/2007	Billings	D604,784	S	11/2009	Horacek et al.
7,198,575	B2	4/2007	Beach et al.	7,621,823	B2	11/2009	Beach et al.
7,201,669	B2	4/2007	Stites et al.	7,628,707	B2	12/2009	Beach et al.
D543,600	S	5/2007	Oldknow	7,632,194	B2	12/2009	Beach et al.
7,211,005	B2	5/2007	Lindsay	7,632,196	B2	12/2009	Reed et al.
7,211,006	B2	5/2007	Chang	D608,850	S	1/2010	Oldknow
7,214,143	B2	5/2007	Deshmukh	D609,294	S	2/2010	Oldknow
7,223,180	B2	5/2007	Willett et al.	D609,295	S	2/2010	Oldknow
D544,939	S	6/2007	Radcliffe et al.	D609,296	S	2/2010	Oldknow
7,226,366	B2	6/2007	Galloway	D609,763	S	2/2010	Oldknow
7,250,007	B2	7/2007	Lu	D609,764	S	2/2010	Oldknow
7,252,600	B2	8/2007	Murphy et al.	D611,555	S	3/2010	Oldknow
7,255,654	B2	8/2007	Murphy et al.	D612,004	S	3/2010	Oldknow
7,258,626	B2	8/2007	Gibbs et al.	D612,005	S	3/2010	Oldknow
7,258,631	B2	8/2007	Galloway et al.	D612,440	S	3/2010	Oldknow
7,267,620	B2	9/2007	Chao et al.	7,674,187	B2	3/2010	Cackett et al.
7,273,423	B2	9/2007	Imamoto	7,674,189	B2	3/2010	Beach et al.
D552,701	S	10/2007	Ruggiero et al.	7,682,264	B2	3/2010	Hsu et al.
7,278,927	B2	10/2007	Gibbs et al.	7,717,807	B2	5/2010	Evans et al.
7,281,985	B2	10/2007	Galloway	D616,952	S	6/2010	Oldknow
D554,720	S	11/2007	Barez et al.	7,731,603	B2	6/2010	Beach et al.
7,291,074	B2	11/2007	Kouno et al.	7,744,484	B1	6/2010	Chao
7,294,064	B2	11/2007	Tsurumaki et al.	7,749,096	B2	7/2010	Gibbs et al.
7,294,065	B2	11/2007	Liang et al.	7,749,097	B2	7/2010	Foster et al.
7,297,072	B2	11/2007	Meyer et al.	7,753,806	B2	7/2010	Beach et al.
7,303,488	B2	12/2007	Kakiuchi et al.	7,771,291	B1	8/2010	Willett et al.
7,306,527	B2	12/2007	Williams et al.	7,789,773	B2	9/2010	Rae et al.
7,314,418	B2	1/2008	Galloway et al.	7,815,520	B2	10/2010	Frame et al.
7,318,782	B2	1/2008	Imamoto et al.	7,857,711	B2	12/2010	Shear
7,320,646	B2	1/2008	Galloway et al.	7,857,713	B2	12/2010	Yokota
D561,286	S	2/2008	Morales et al.	D631,119	S	1/2011	Albertsen et al.
7,344,452	B2	3/2008	Imamoto et al.	7,867,105	B2	1/2011	Moon
7,347,795	B2	3/2008	Yamgishi et al.	7,887,434	B2	2/2011	Beach et al.
D567,317	S	4/2008	Jertson et al.	7,927,229	B2	4/2011	Jertson et al.
7,354,355	B2	4/2008	Tavares et al.	7,946,931	B2	5/2011	Oyama
7,377,860	B2	5/2008	Breier et al.	7,988,565	B2	8/2011	Abe
				8,012,038	B1	9/2011	Beach et al.
				8,012,039	B2	9/2011	Greaney et al.
				8,083,609	B2	12/2011	Burnett et al.
				8,088,021	B2	1/2012	Albertsen et al.

(56)

References Cited

U.S. PATENT DOCUMENTS

8,096,897 B2	1/2012	Beach et al.	2005/0101404 A1	5/2005	Long et al.
8,118,689 B2	2/2012	Beach et al.	2005/0119070 A1	6/2005	Kumamoto
8,157,672 B2	4/2012	Greaney et al.	2005/0137024 A1	6/2005	Stites et al.
8,162,775 B2	4/2012	Tavares et al.	2005/0181884 A1	8/2005	Beach et al.
8,167,737 B2	5/2012	Oyama	2005/0239575 A1	10/2005	Chao et al.
8,187,119 B2	5/2012	Rae et al.	2005/0239576 A1	10/2005	Stites et al.
8,206,241 B2	6/2012	Boyd et al.	2006/0009305 A1	1/2006	Lindsay
8,206,244 B2	6/2012	Honea et al.	2006/0035722 A1	2/2006	Beach et al.
8,216,087 B2	7/2012	Breier et al.	2006/0052177 A1	3/2006	Nakahara et al.
8,235,841 B2	8/2012	Stites et al.	2006/0058112 A1	3/2006	Haralason et al.
8,235,844 B2	8/2012	Albertsen et al.	2006/0073910 A1	4/2006	Imamoto et al.
8,241,143 B2	8/2012	Albertsen et al.	2006/0084525 A1	4/2006	Imamoto et al.
8,241,144 B2	8/2012	Albertsen et al.	2006/0094535 A1	5/2006	Cameron
8,292,756 B2	10/2012	Greaney et al.	2006/0116218 A1	6/2006	Burnett et al.
8,328,659 B2	12/2012	Shear	2006/0122004 A1	6/2006	Chen et al.
8,353,786 B2	1/2013	Beach et al.	2006/0154747 A1	7/2006	Beach
8,403,771 B1	3/2013	Rice et al.	2006/0172821 A1	8/2006	Evans et al.
8,430,763 B2	4/2013	Beach et al.	2006/0240908 A1	10/2006	Adams et al.
8,435,134 B2	5/2013	Tang et al.	2006/0281581 A1	12/2006	Yamamoto
8,496,544 B2	7/2013	Curtis et al.	2007/0026961 A1	2/2007	Hou
8,517,860 B2	8/2013	Albertsen	2007/0049416 A1	3/2007	Shear
8,529,368 B2	9/2013	Rice et al.	2007/0049417 A1	3/2007	Shear
8,591,351 B2	11/2013	Albertsen	2007/0082751 A1	4/2007	Lo et al.
8,616,999 B2	12/2013	Greaney et al.	2007/0099726 A1	5/2007	Rife
8,641,555 B2	2/2014	Stites et al.	2007/0105646 A1	5/2007	Beach et al.
8,663,029 B2	3/2014	Beach et al.	2007/0105647 A1	5/2007	Beach et al.
8,696,491 B1	4/2014	Myers	2007/0105648 A1	5/2007	Beach et al.
8,721,471 B2	5/2014	Albertsen et al.	2007/0105649 A1	5/2007	Beach et al.
8,753,222 B2	6/2014	Beach et al.	2007/0105650 A1	5/2007	Beach et al.
8,821,312 B2	9/2014	Burnett et al.	2007/0105651 A1	5/2007	Beach et al.
8,827,831 B2	9/2014	Burnett et al.	2007/0105652 A1	5/2007	Beach et al.
8,834,289 B2	9/2014	de la Cruz et al.	2007/0105653 A1	5/2007	Beach et al.
8,858,360 B2	10/2014	Rice et al.	2007/0105654 A1	5/2007	Beach et al.
8,900,069 B2	12/2014	Beach et al.	2007/0105655 A1	5/2007	Beach et al.
8,956,240 B2	2/2015	Beach et al.	2007/0117648 A1	5/2007	Yokota
9,011,267 B2	4/2015	Burnett et al.	2007/0117652 A1	5/2007	Beach et al.
9,089,749 B2	7/2015	Burnett et al.	2007/0238551 A1	10/2007	Yokota
9,168,428 B2	10/2015	Albertsen et al.	2007/0275792 A1	11/2007	Horacek et al.
9,168,434 B2	10/2015	Burnett et al.	2008/0146370 A1	6/2008	Beach et al.
9,174,101 B2	11/2015	Burnett et al.	2008/0161127 A1	7/2008	Yamamoto
9,265,993 B2	2/2016	Albertsen et al.	2008/0171612 A1	7/2008	Serrano et al.
9,403,069 B2	8/2016	Boyd et al.	2008/0182681 A1	7/2008	Yokota
9,566,479 B2	2/2017	Albertsen et al.	2008/0254911 A1	10/2008	Beach et al.
9,610,482 B2*	4/2017	Burnett A63B 53/0466	2008/0261715 A1	10/2008	Carter
9,610,483 B2*	4/2017	Burnett A63B 53/0466	2008/0261717 A1	10/2008	Hoffman et al.
2001/0049310 A1	12/2001	Cheng et al.	2008/0268980 A1	10/2008	Breier et al.
2002/0022535 A1	2/2002	Takeda	2008/0268981 A1	10/2008	Evans
2002/0025861 A1	2/2002	Ezawa	2008/0280698 A1	11/2008	Hoffman et al.
2002/0032075 A1	3/2002	Vatsvog	2009/0069114 A1	3/2009	Foster et al.
2002/0055396 A1	5/2002	Nishimoto et al.	2009/0082135 A1	3/2009	Evans et al.
2002/0072434 A1	6/2002	Yabu	2009/0088269 A1	4/2009	Beach et al.
2002/0077195 A1	6/2002	Carr et al.	2009/0088271 A1	4/2009	Beach et al.
2002/0115501 A1	8/2002	Chen	2009/0137338 A1	5/2009	Kajita
2002/0123394 A1	9/2002	Tsurumaki	2009/0170632 A1	7/2009	Beach et al.
2002/0137576 A1	9/2002	Dammen	2009/0181789 A1	7/2009	Reed et al.
2002/0160854 A1	10/2002	Beach et al.	2009/0286622 A1	11/2009	Yokota
2002/0183130 A1	12/2002	Pacinella	2010/0029404 A1	2/2010	Shear
2002/0183134 A1	12/2002	Allen et al.	2010/0048316 A1	2/2010	Honea et al.
2003/0013545 A1	1/2003	Vincent et al.	2010/0048321 A1	2/2010	Beach et al.
2003/0032500 A1	2/2003	Nakahara et al.	2010/0113176 A1	5/2010	Boyd et al.
2003/0036442 A1	2/2003	Chao et al.	2010/0178997 A1	7/2010	Gibbs et al.
2003/0130059 A1	7/2003	Billings	2011/0021284 A1	1/2011	Stites et al.
2003/0176238 A1	9/2003	Galloway et al.	2011/0151989 A1	6/2011	Golden et al.
2003/0220154 A1	11/2003	Anelli	2011/0151997 A1	6/2011	Shear
2004/0087388 A1	5/2004	Beach et al.	2011/0218053 A1	9/2011	Tang et al.
2004/0121852 A1	6/2004	Tsurumaki	2011/0244979 A1	10/2011	Snyder
2004/0157678 A1	8/2004	Kohno	2011/0281663 A1	11/2011	Stites et al.
2004/0176180 A1	9/2004	Yamaguchi et al.	2011/0281664 A1	11/2011	Boyd et al.
2004/0176183 A1	9/2004	Tsurumaki	2011/0294599 A1	12/2011	Albertsen et al.
2004/0192463 A1	9/2004	Tsurumaki et al.	2012/0034997 A1	2/2012	Swartz
2004/0235584 A1	11/2004	Chao et al.	2012/0083362 A1	4/2012	Albertsen et al.
2004/0242343 A1	12/2004	Chao et al.	2012/0083363 A1	4/2012	Albertsen et al.
2005/0003905 A1	1/2005	Kim et al.	2012/0135821 A1	5/2012	Boyd et al.
2005/0026716 A1	2/2005	Wahl et al.	2012/0142447 A1	6/2012	Boyd et al.
2005/0049081 A1	3/2005	Boone	2012/0142452 A1	6/2012	Burnett et al.
			2012/0178548 A1	7/2012	Tavares et al.
			2012/0196701 A1	8/2012	Stites et al.
			2012/0196703 A1	8/2012	Sander
			2012/0244960 A1	9/2012	Tang et al.

(56)

References Cited

U.S. PATENT DOCUMENTS

2012/0270676 A1 10/2012 Burnett et al.
 2012/0277029 A1 11/2012 Albertsen et al.
 2012/0277030 A1 11/2012 Albertsen et al.
 2012/0289361 A1 11/2012 Beach et al.
 2013/0184100 A1 7/2013 Burnett et al.
 2013/0210542 A1 8/2013 Harbert et al.
 2014/0148270 A1 5/2014 Oldknow
 2015/0105177 A1 4/2015 Beach et al.
 2015/0231453 A1 8/2015 Harbert et al.

FOREIGN PATENT DOCUMENTS

CN 103877712 6/2014
 CN 104168965 11/2014
 DE 9012884 9/1990
 EP 0470488 2/1992
 EP 0617987 11/1997
 EP 1001175 5/2000
 FR 2712197 5/1995
 GB 194823 12/1921
 JP 57-157374 10/1982
 JP 01091876 A2 4/1989
 JP 03049777 A 3/1991
 JP 03151988 A 6/1991
 JP 04180778 A 6/1992
 JP 4180778 A2 6/1992
 JP 05337220 A 12/1993
 JP H05317465 12/1993
 JP H06121851 5/1994
 JP H06126004 5/1994
 JP 06182004 A 7/1994
 JP 06190088 7/1994
 JP H06190088 7/1994
 JP H06238022 8/1994
 JP 06285186 A 10/1994
 JP H06304271 11/1994
 JP 08117365 A 5/1996
 JP H09028844 2/1997
 JP 3035480 3/1997
 JP H09308717 12/1997
 JP H09327534 12/1997
 JP 10155943 A 6/1998
 JP H10192453 7/1998
 JP H10234902 9/1998
 JP 10263118 A 10/1998
 JP H10277187 10/1998
 JP H11114102 4/1999
 JP 11-155982 6/1999
 JP 2000167089 A 6/2000
 JP 2000288131 A 10/2000
 JP 2000296192 10/2000
 JP 2000300701 A 10/2000
 JP 2000342721 A 12/2000
 JP 2000014841 A 1/2001
 JP 2001054595 2/2001
 JP 2001129130 5/2001
 JP 2001170225 6/2001
 JP 2001204856 7/2001
 JP 2001231888 A 8/2001
 JP 2001346918 12/2001
 JP 2002003969 1/2002
 JP 2002017910 1/2002
 JP 2002052099 2/2002
 JP 2002052100 2/2002
 JP 2002136625 5/2002
 JP 2002248183 A 9/2002
 JP 2002248183 A 9/2002
 JP 2002253706 9/2002
 JP 2003024481 A 1/2003
 JP 2003038691 2/2003
 JP 2003052866 2/2003
 JP 2003093554 4/2003
 JP 2003126311 5/2003
 JP 2003210621 7/2003
 JP 2003210627 A 7/2003

JP 2003226952 8/2003
 JP 2003524487 8/2003
 JP 2004008409 1/2004
 JP 2004113370 4/2004
 JP 2004174224 6/2004
 JP 2004183058 7/2004
 JP 2004222911 8/2004
 JP 2004232397 8/2004
 JP 2004261451 9/2004
 JP 2004265992 9/2004
 JP 2004267438 9/2004
 JP 2004271516 9/2004
 JP 2004275700 10/2004
 JP 2004313762 11/2004
 JP 2004-351054 12/2004
 JP 2004351054 12/2004
 JP 2004351173 12/2004
 JP 2005028170 2/2005
 JP 2005073736 3/2005
 JP 2005111172 4/2005
 JP 2005137494 6/2005
 JP 2005137788 6/2005
 JP 2005137940 6/2005
 JP 2005193069 7/2005
 JP 2005296458 10/2005
 JP 2005296582 10/2005
 JP 2005323978 11/2005
 JP 3819409 9/2006
 JP 2006320493 11/2006
 JP 2007136069 6/2007
 JP 3996539 10/2007
 JP 2007275253 A 10/2007
 JP 4046511 2/2008
 JP 4047682 2/2008
 JP 4128970 7/2008
 JP 2009000281 A 1/2009
 JP 2009000292 1/2009
 JP 2010029590 A 2/2010
 JP 2010279847 A 12/2010
 JP 2011024999 A 2/2011
 JP 2012526621 11/2012
 JP 2012526634 11/2012
 JP 2013517893 5/2013
 JP 2013517894 5/2013
 JP 2013517895 5/2013
 JP 2013255779 12/2013
 JP 2013544178 12/2013
 JP 2013544179 12/2013
 JP 5404921 2/2014
 JP 2014140591 8/2014
 JP 2014528291 10/2014
 JP 5625048 B 11/2014
 JP 5653457 1/2015
 JP 2015517886 6/2015
 JP 5827243 12/2015
 JP 2017012769 1/2017
 JP 6072696 2/2017
 JP 6096892 3/2017
 JP 2017080609 5/2017
 KR 100768417 8/2005
 KR 20050084089 8/2005
 KR 20070111156 11/2007
 WO WO8802642 4/1988
 WO WO0166199 9/2001
 WO WO02062501 8/2002
 WO WO03061773 7/2003
 WO WO2004043549 5/2004
 WO WO2005/009543 A2 2/2005
 WO WO2006044631 4/2006
 WO WO2011017011 2/2011
 WO WO2012075177 6/2012
 WO WO2012075178 6/2012
 WO WO2012103340 8/2012

OTHER PUBLICATIONS

"Invalidity Search Report for Japanese Registered Patent No. 4128970,"
 4 pp (Nov. 29, 2013).

(56)

References Cited

OTHER PUBLICATIONS

Office action from the U.S. Patent and Trademark Office in U.S. Appl. No. 13/401,690, dated Feb. 6, 2013.
 Office action from the U.S. Patent and Trademark Office in U.S. Appl. No. 13/469,023, dated Jul. 31, 2012.
 Office action from the U.S. Patent and Trademark Office in U.S. Appl. No. 13/338,197, dated Jun. 5, 2014.
 Office action from the U.S. Patent and Trademark Office in U.S. Appl. No. 13/828,675, dated Jun. 30, 2014.
 Restriction Requirement from the U.S. Patent and Trademark Office in U.S. Appl. No. 13/469,031, dated Jun. 5, 2014.
 Office action from the U.S. Patent and Trademark office in the U.S. Appl. No. 13/401,690, dated May 23, 2012.
 Adams Golf Speedline F11 Ti 14.5 degree fairway wood (www.bombsquadgolf.com, posted Oct. 18, 2010).
 Callaway Golf, World's Straightest Driver: FT-i Driver downloaded from www.callawaygolf.com/ft%2Di/driver.aspx?lang=en on Apr. 5, 2007.
 Jackson, Jeff, The Modern Guide to Golf Clubmaking, Ohio: Dynacraft Golf Products, Inc., copyright 1994, p. 237.
 Nike Golf, Sasquatch 460, downloaded from www.nike.com/nikegolf/index.htm on Apr. 5, 2007.
 Nike Golf, Sasquatch Sumo Squared Driver, downloaded from www.nike.com/nikegolf/index.htm on Apr. 5, 2007.
 Office action from the U.S. Patent and Trademark office in the U.S. Appl. No. 12/781,727, dated Aug. 5, 2010.

Taylor Made Golf Company, Inc. Press Release, Burner Fairway Wood, www.tmag.com/media/pressreleases/2007/011807_burner_fairway_rescue.html, Jan. 26, 2007.
 Taylor Made Golf Company Inc., R7 460 Drivers, downloaded from www.taylormadegolf.com/product_detail.asp?PID=14section=overview on Apr. 5, 2007.
 Titleist 907D1, downloaded from www.tees2greens.com/forum/Uploads/Images/7ade3521-192b-4611-870b-395d.jpg on Feb. 1, 2007.
 Mike Stachura, "The Hot List", Golf Digest Magazine, Feb. 2004, pp. 82-86.
 Mike Stachura, "The Hot List", Golf Digest Magazine, Feb. 2005, pp. 120-130.
 Mike Stachura, "The Hot List", Golf Digest Magazine, Feb. 2005, pp. 131-143.
 Mike Stachura, "The Hot List", Golf Digest Magazine, Feb. 2006, pp. 122-132.
 Mike Stachura, "The Hot List", Golf Digest Magazine, Feb. 2006, pp. 133-143.
 Mike Stachura, "The Hot List", Golf Digest Magazine, Feb. 2007, pp. 130-151.
 "The Hot List", Golf Digest Magazine, Feb. 2008, pp. 114-139.
 Mike Stachura, Stina Sternberg, "Editor's Choices and Gold Medal Drivers", Golf Digest Magazine, Feb. 2010, pp. 95-109.
 The Hot List, Golf Digest Magazine, Feb. 2009, pp. 101-127.
 International Searching Authority (USPTO), International Search Report and Written Opinion for International Application No. PCT/US2011/038150, dated Sep. 16, 2011, 13 pages.

* cited by examiner

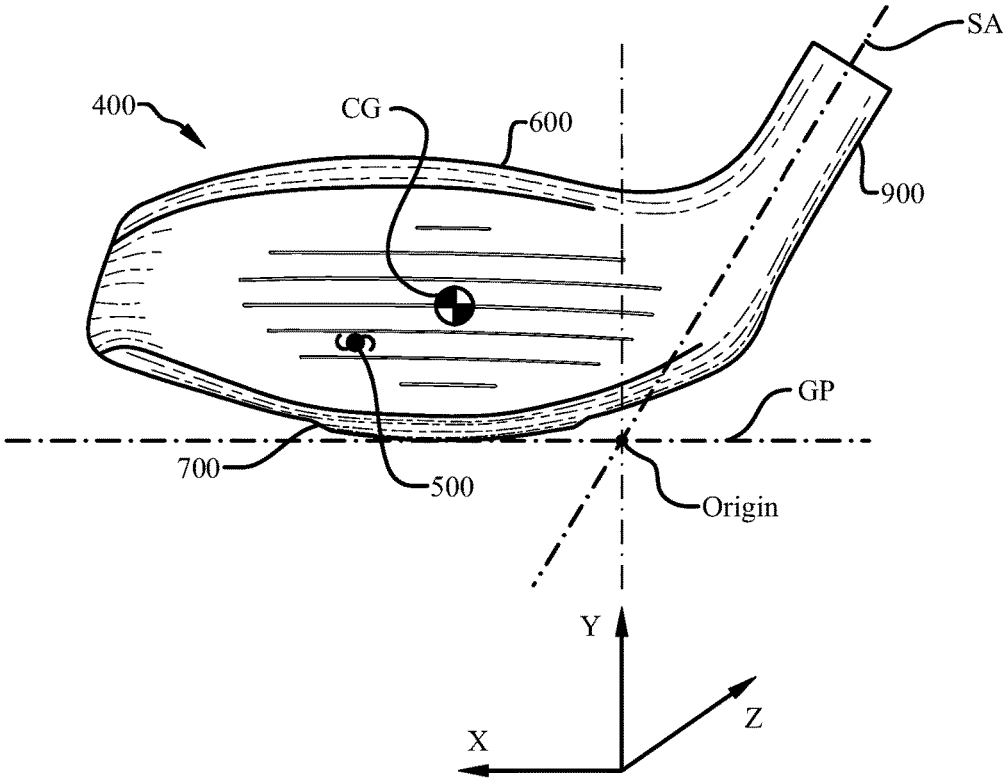

Fig. 1

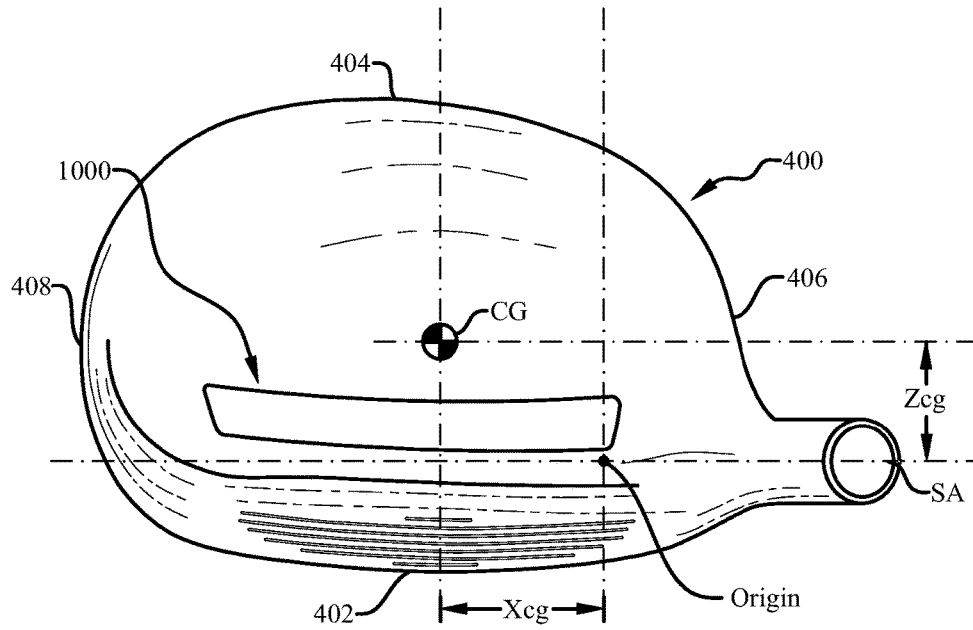

Fig. 2

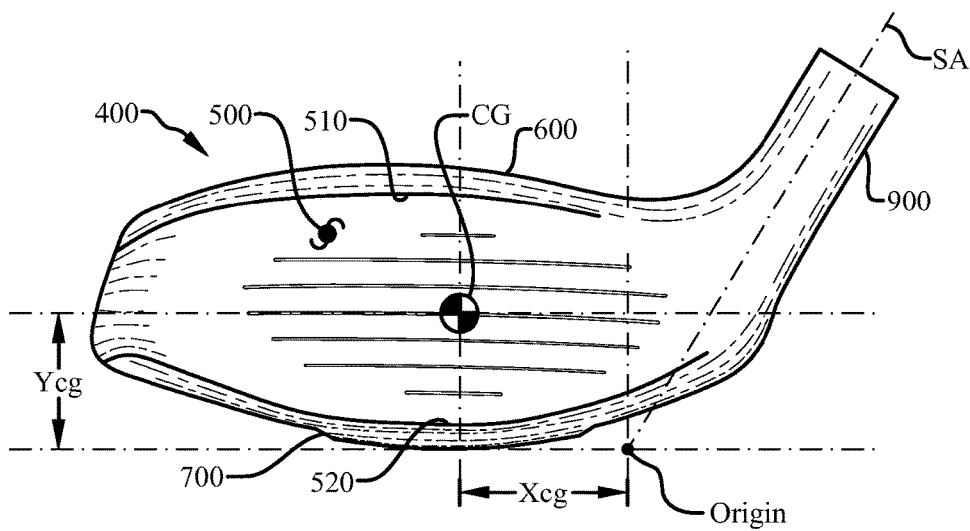

Fig. 3

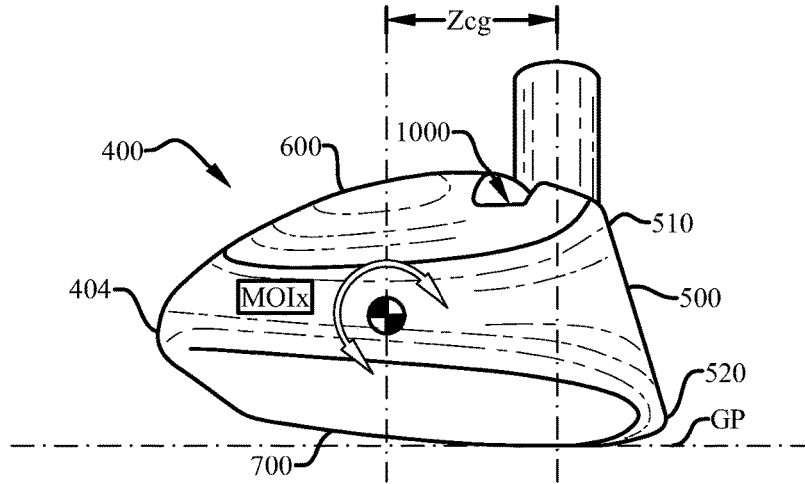

Fig. 4

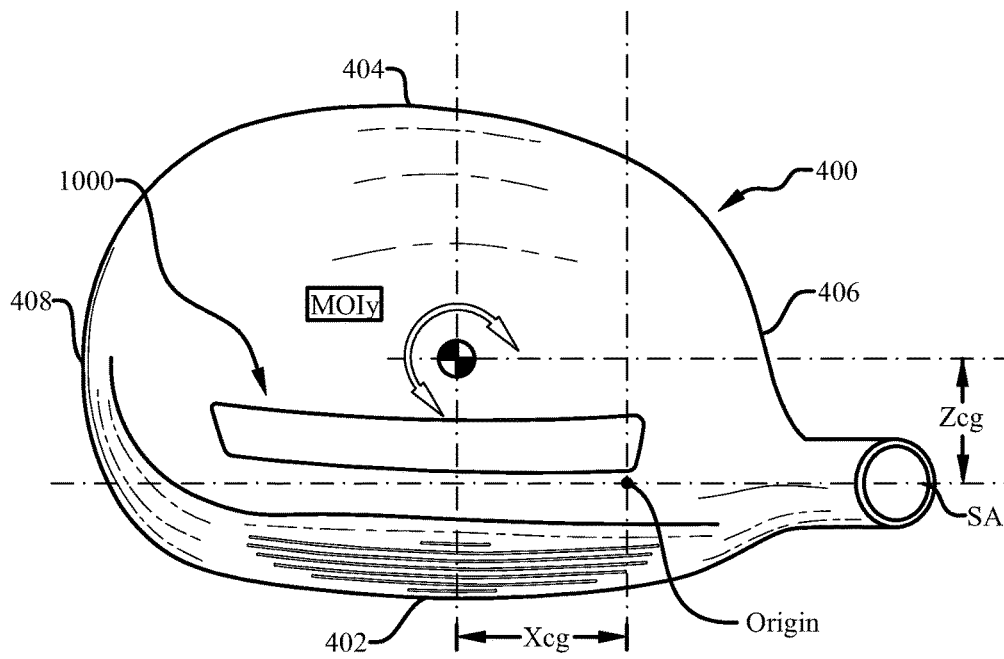

Fig. 5

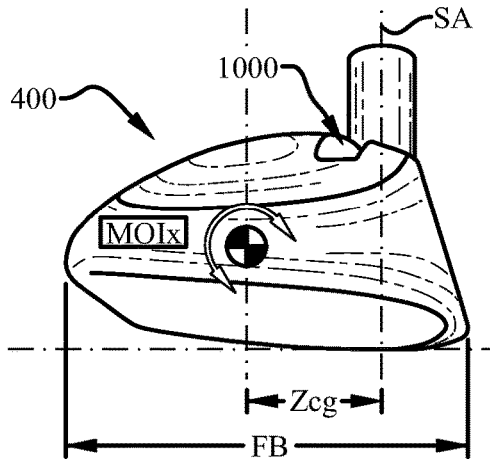

Fig. 6

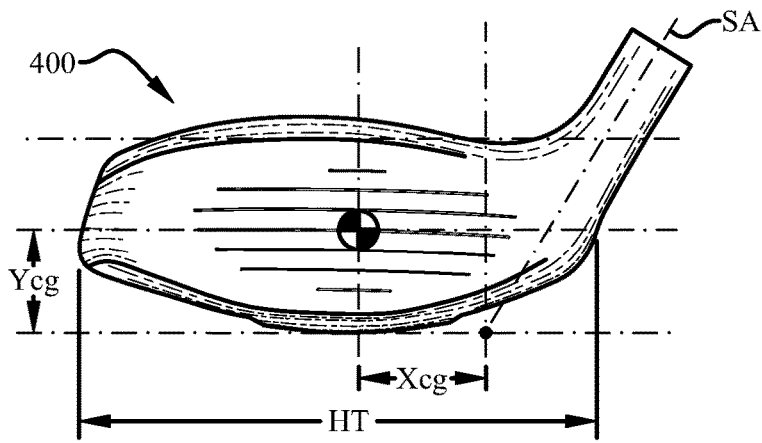

Fig. 7

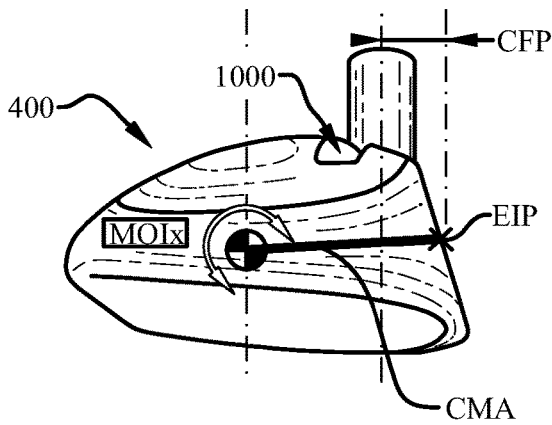

Fig. 8

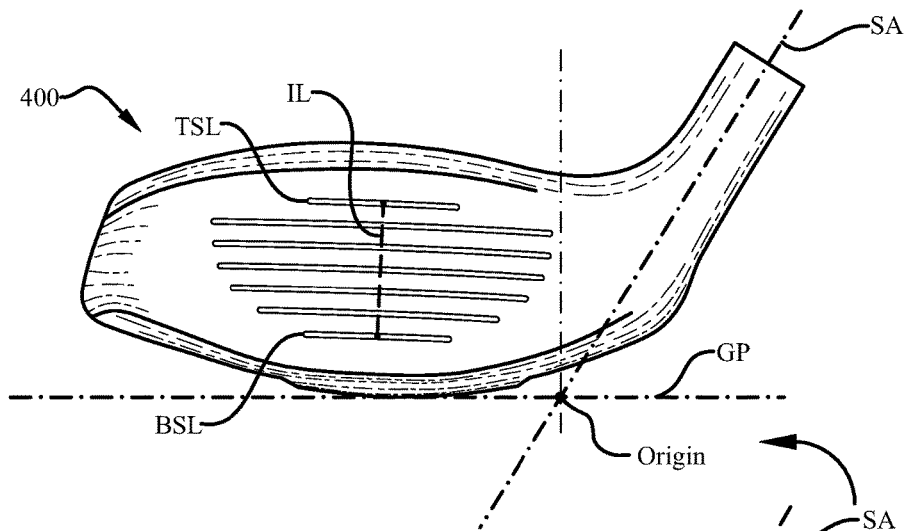

Fig. 9

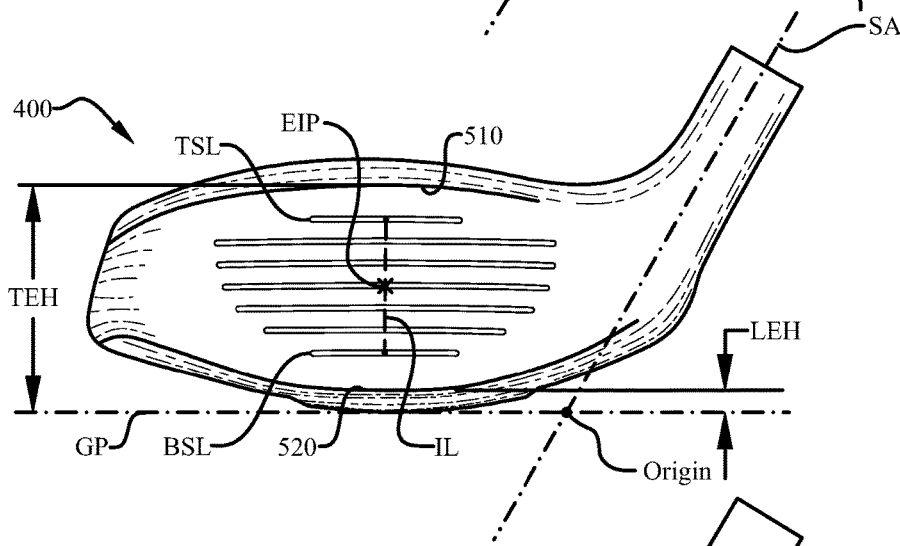

Fig. 10

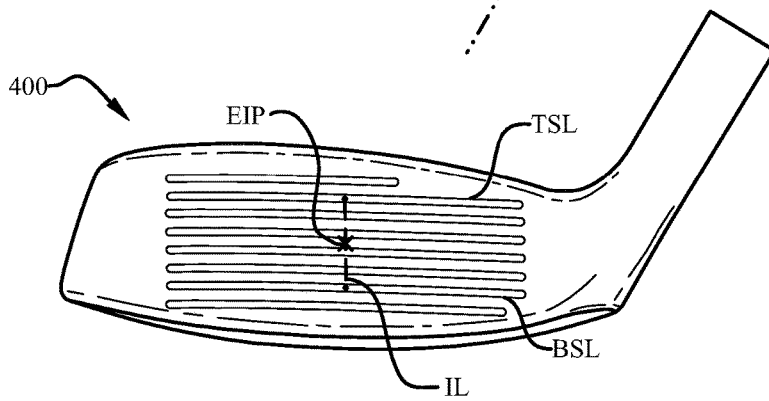

Fig. 11

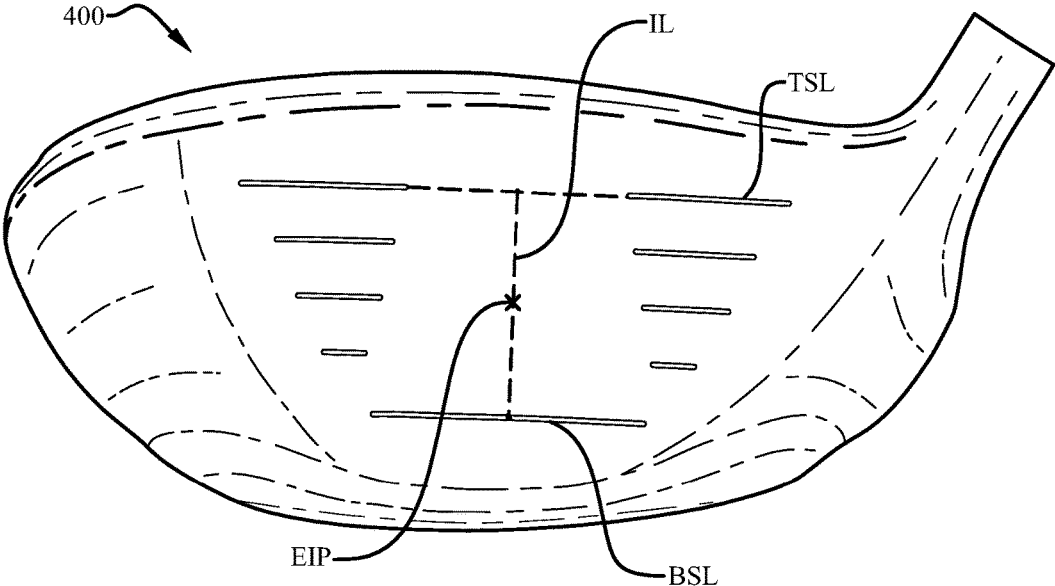

Fig. 12

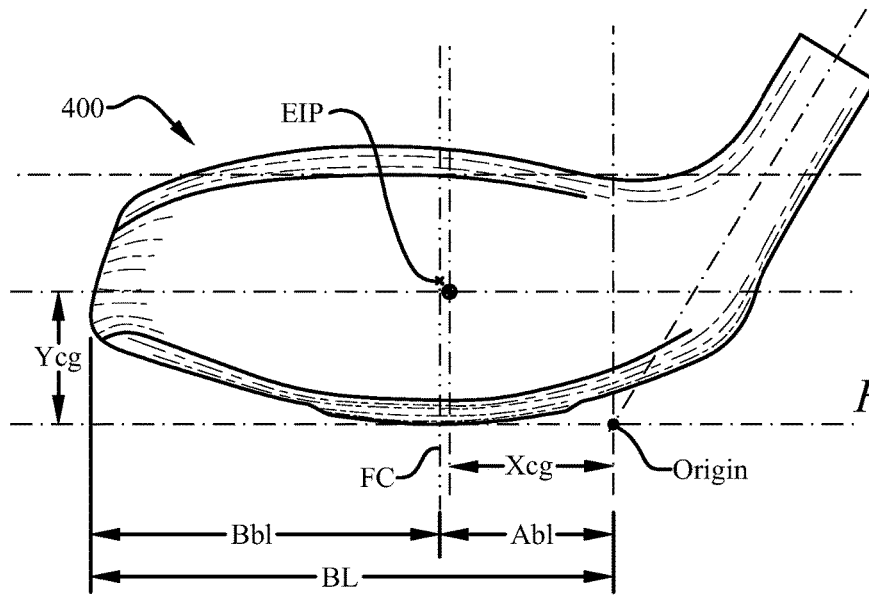

Fig. 13

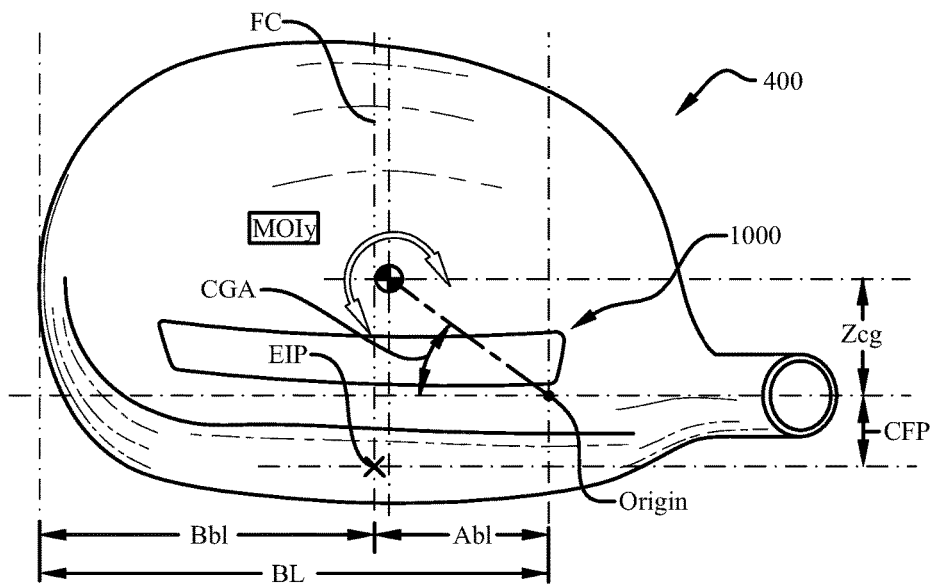

Fig. 14

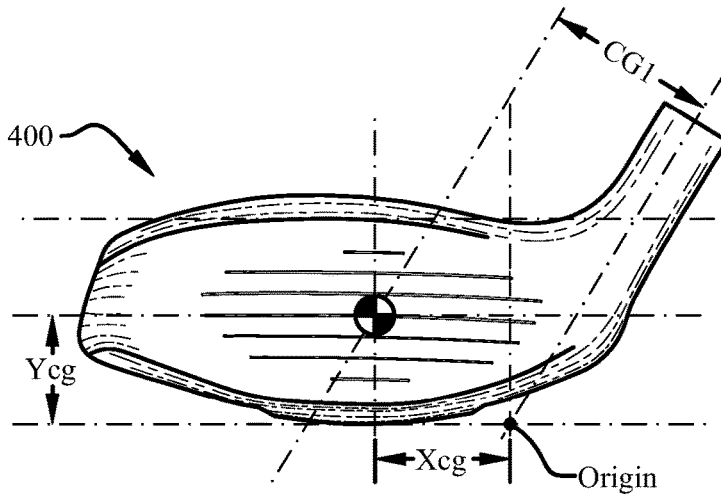

Fig. 15

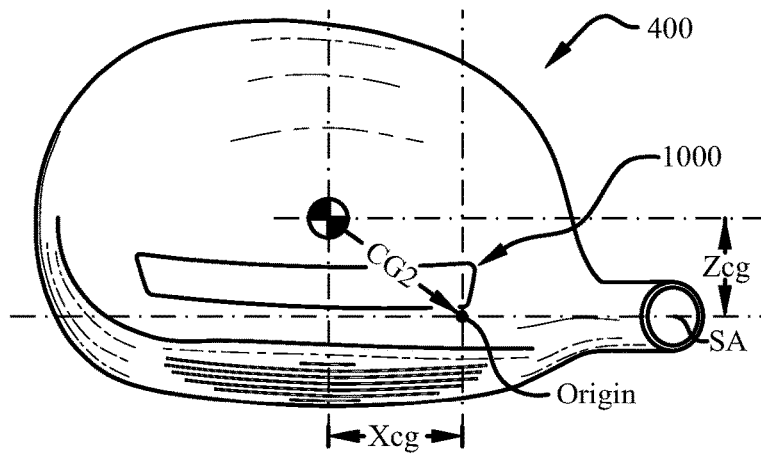

Fig. 16

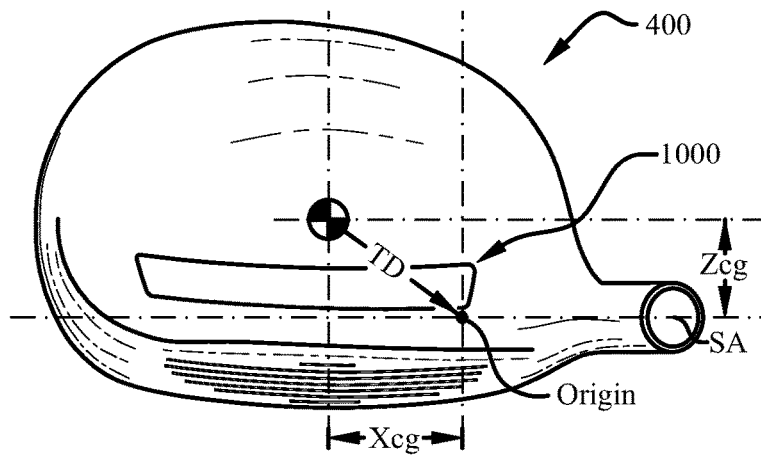

Fig. 17

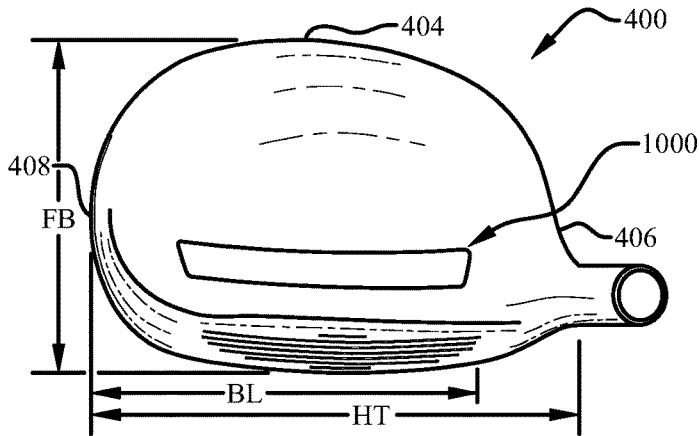

Fig. 18

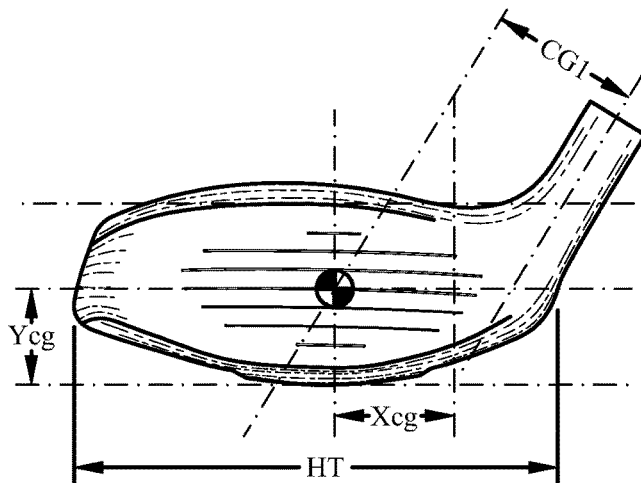

Fig. 19

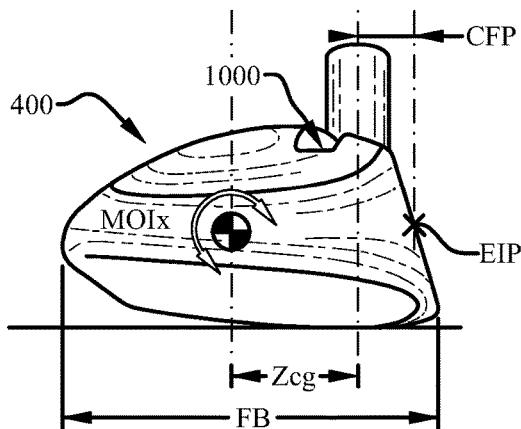

Fig. 20

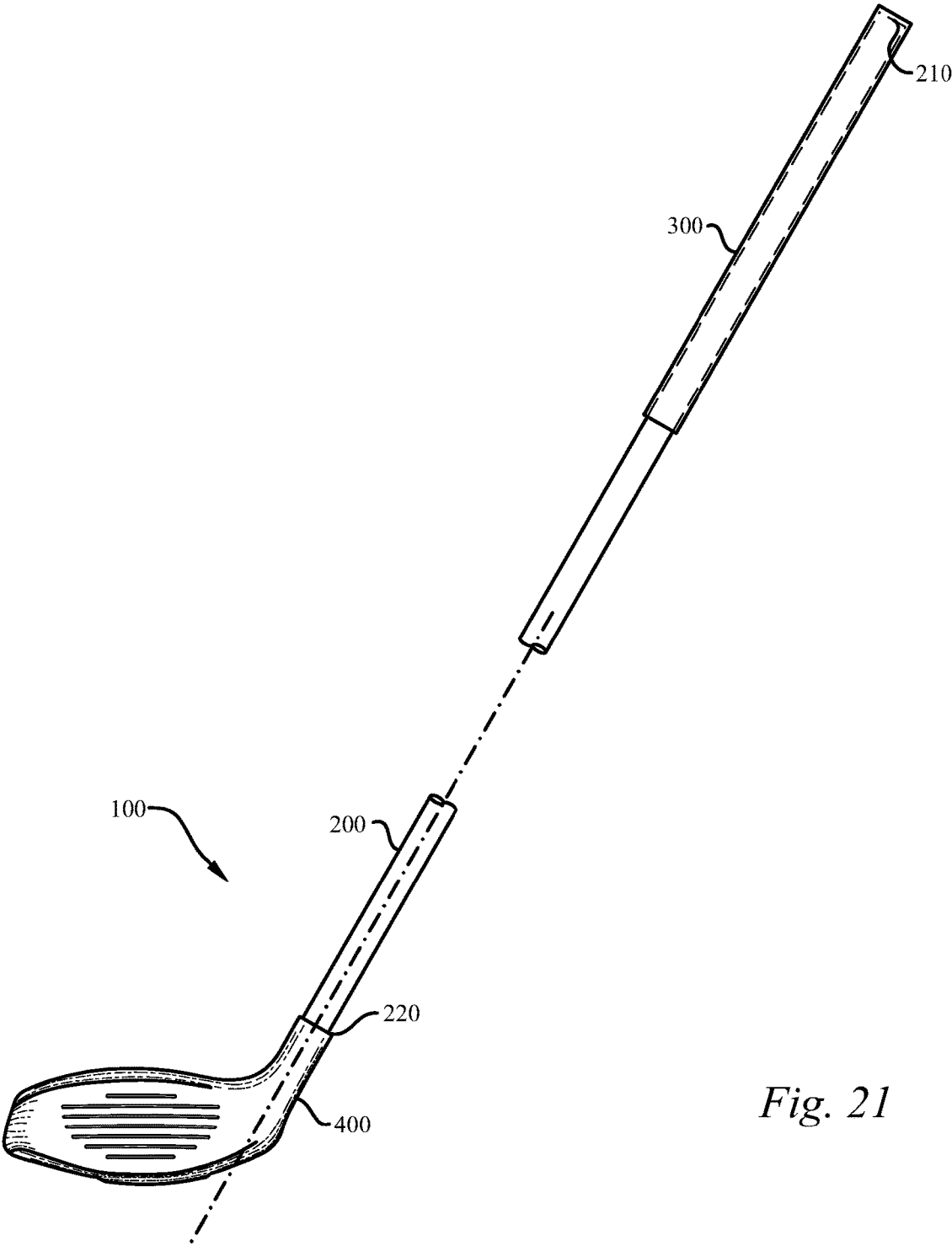

Fig. 21

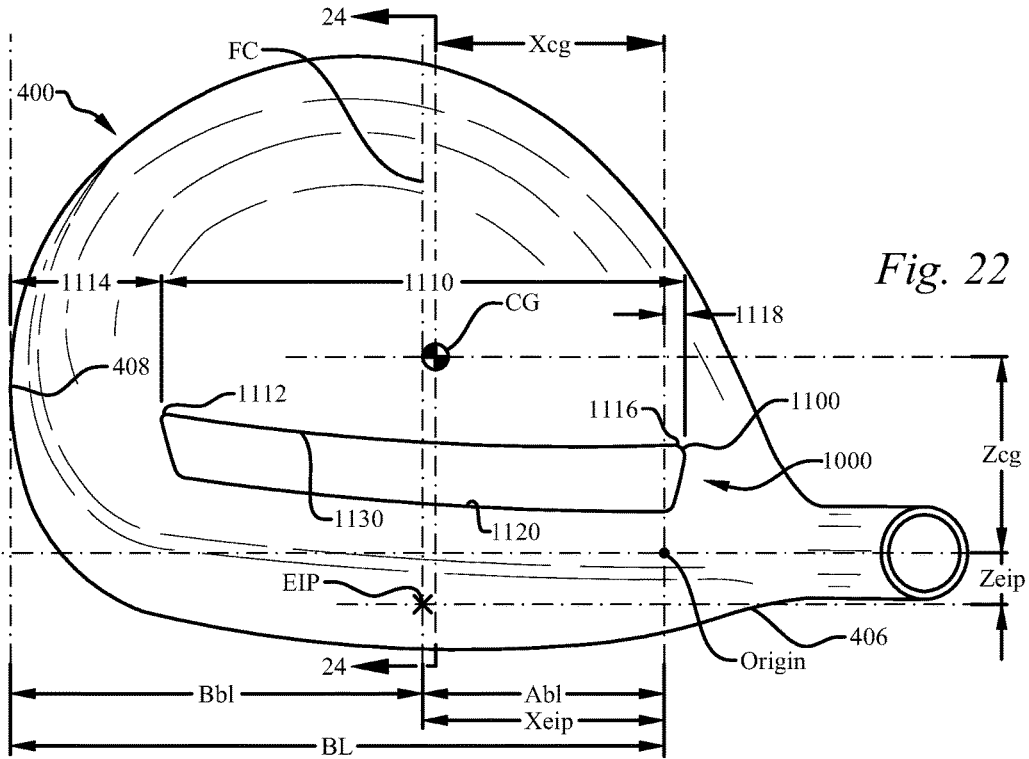

Fig. 22

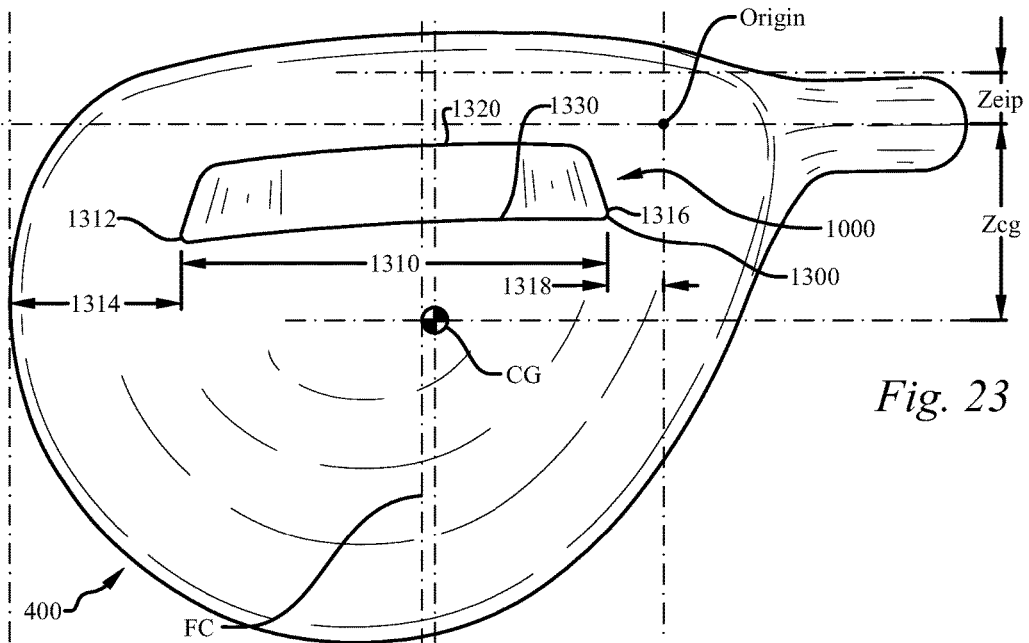

Fig. 23

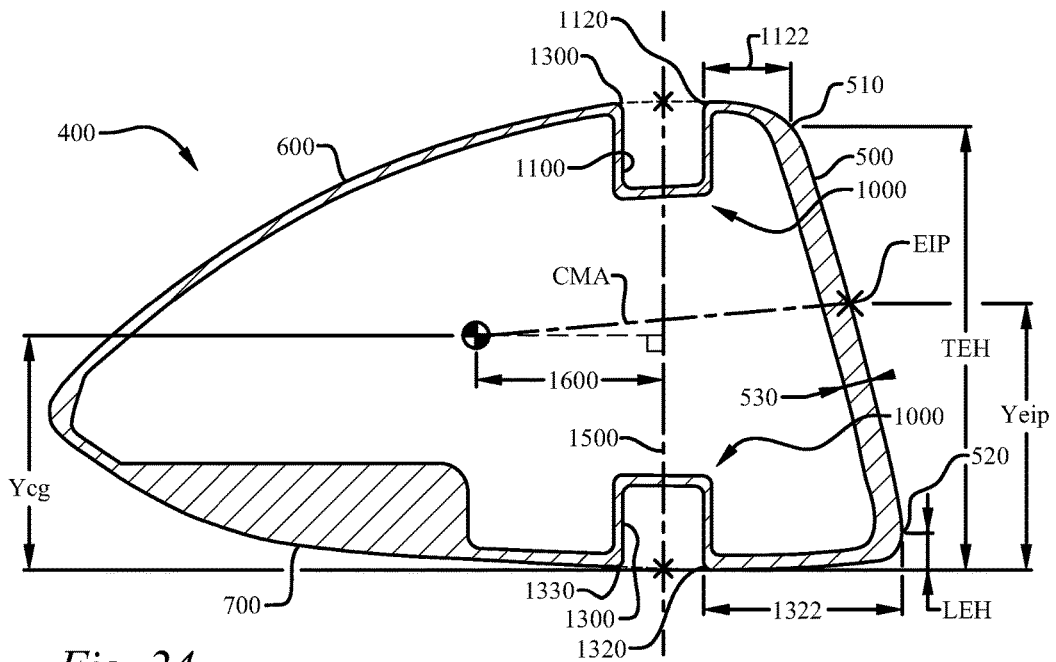

Fig. 24

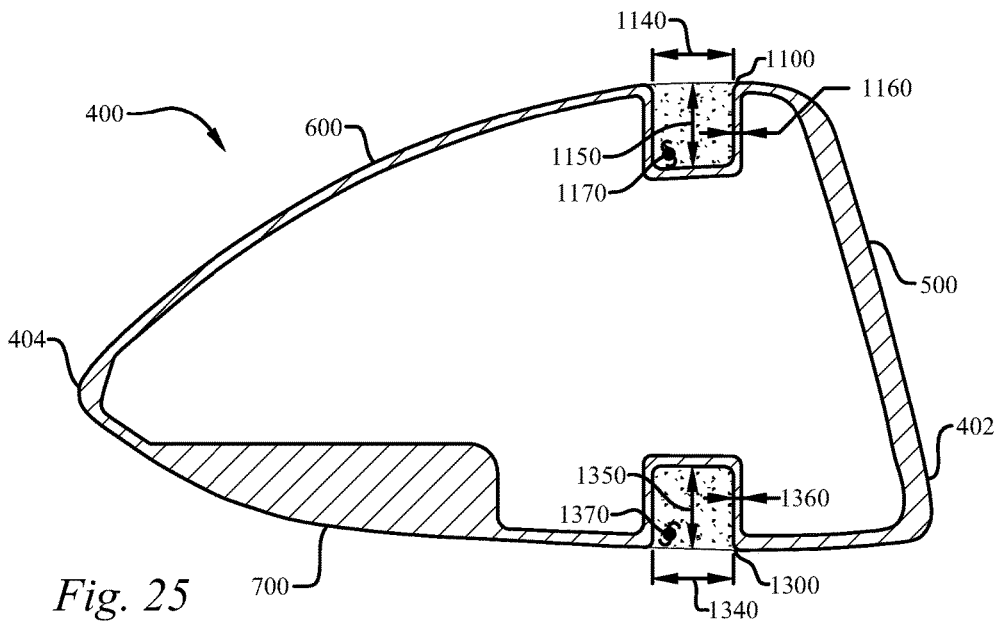

Fig. 25

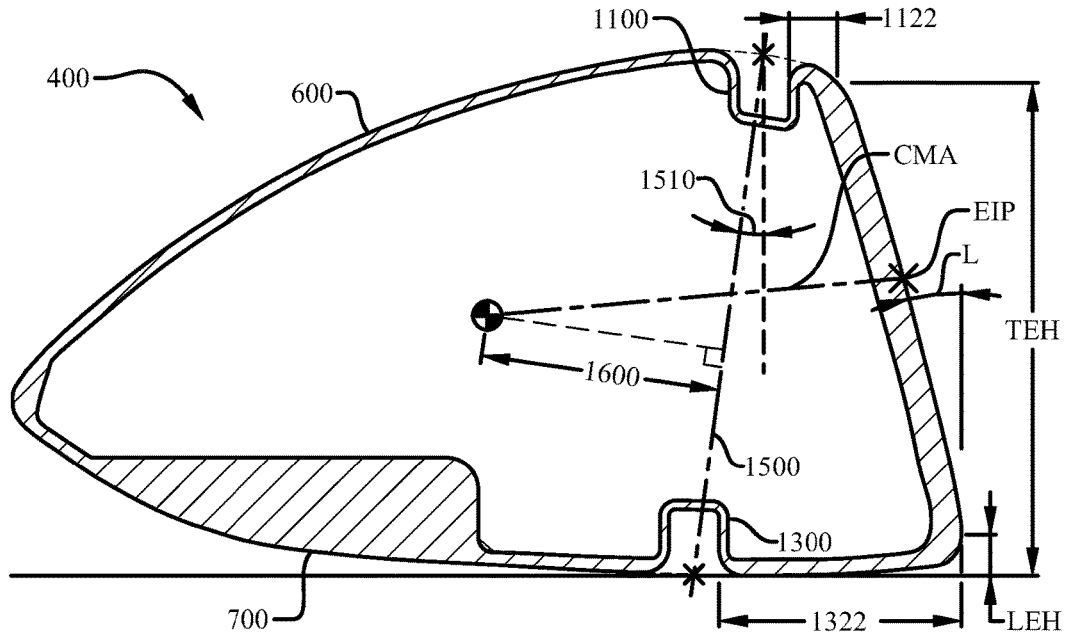

Fig. 26

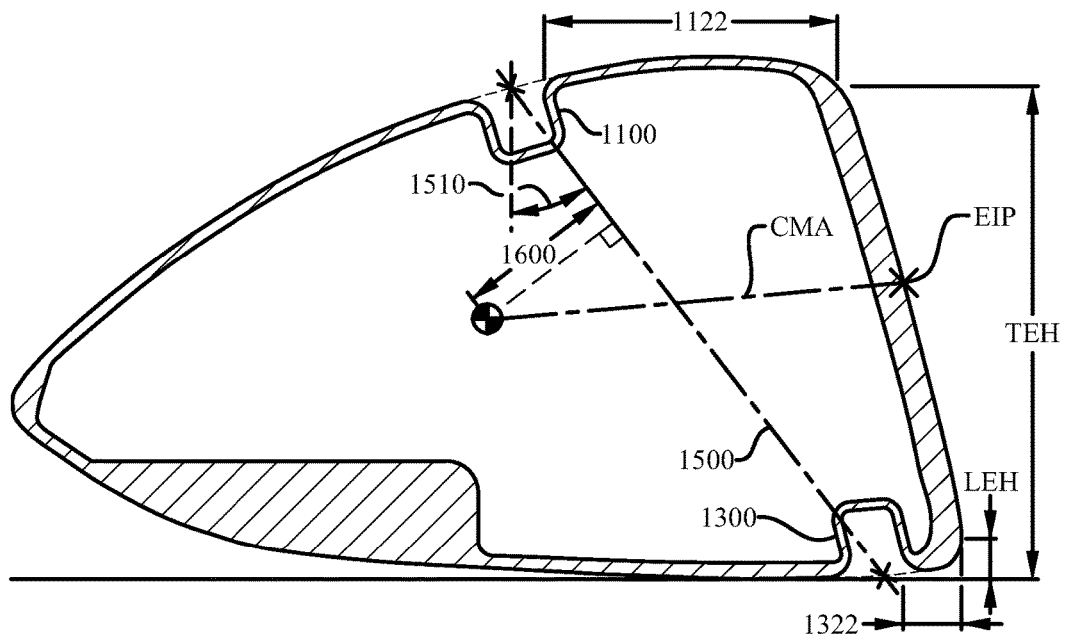

Fig. 27

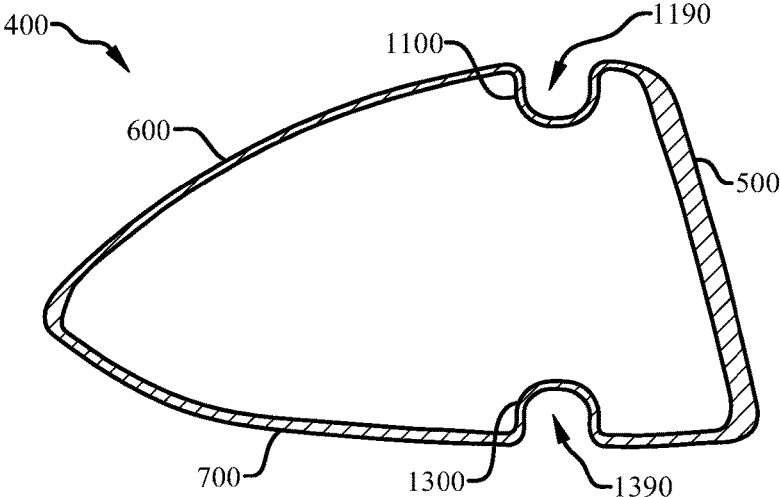

Fig. 28

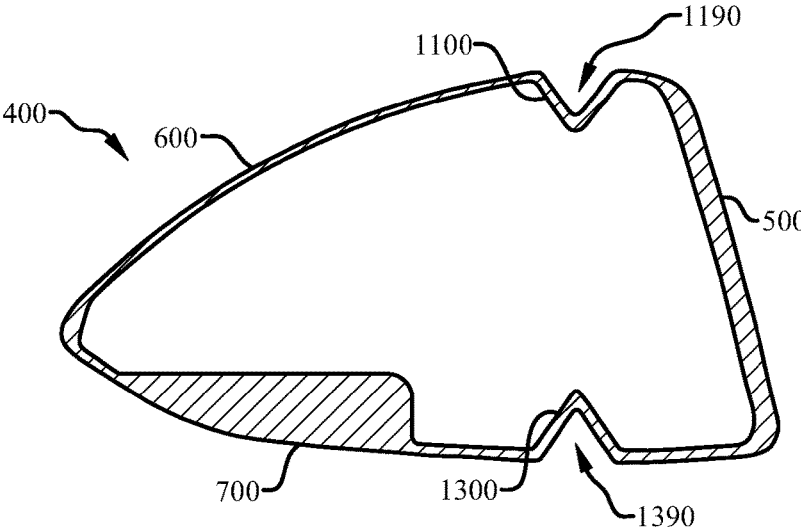

Fig. 29

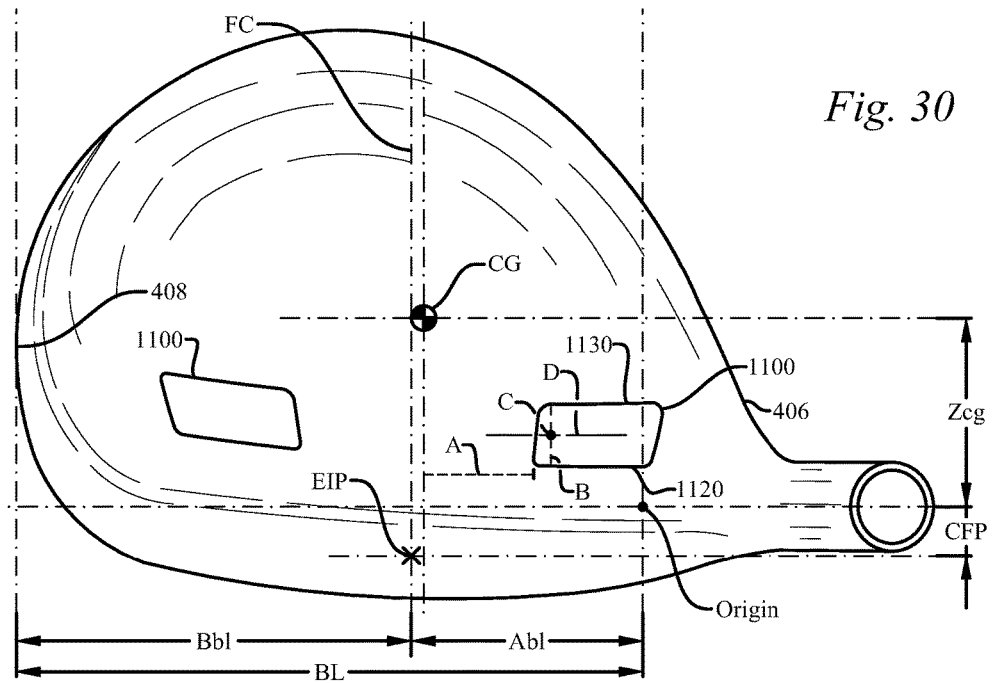

Fig. 30

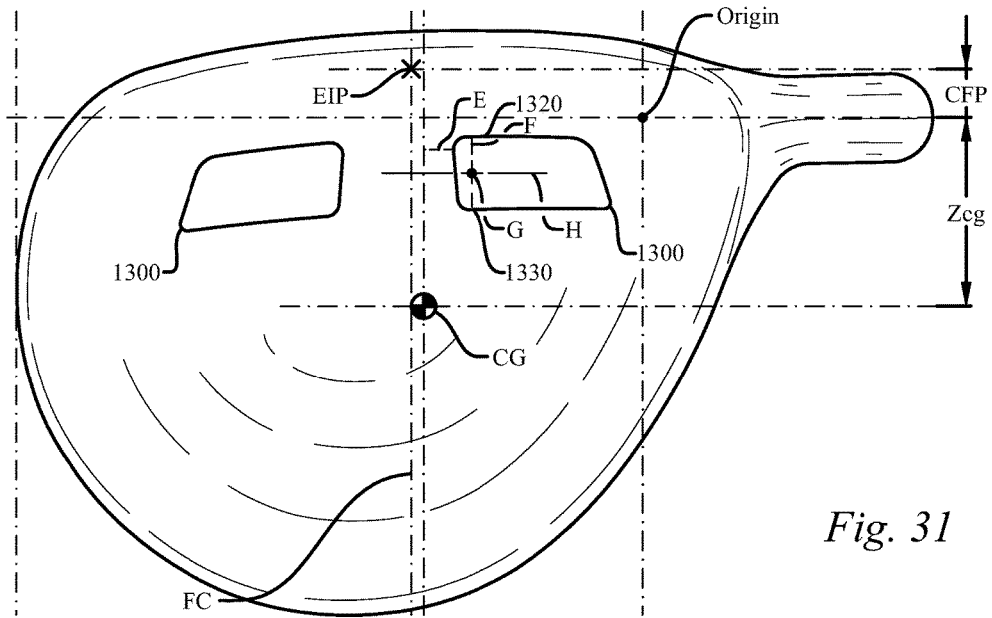

Fig. 31

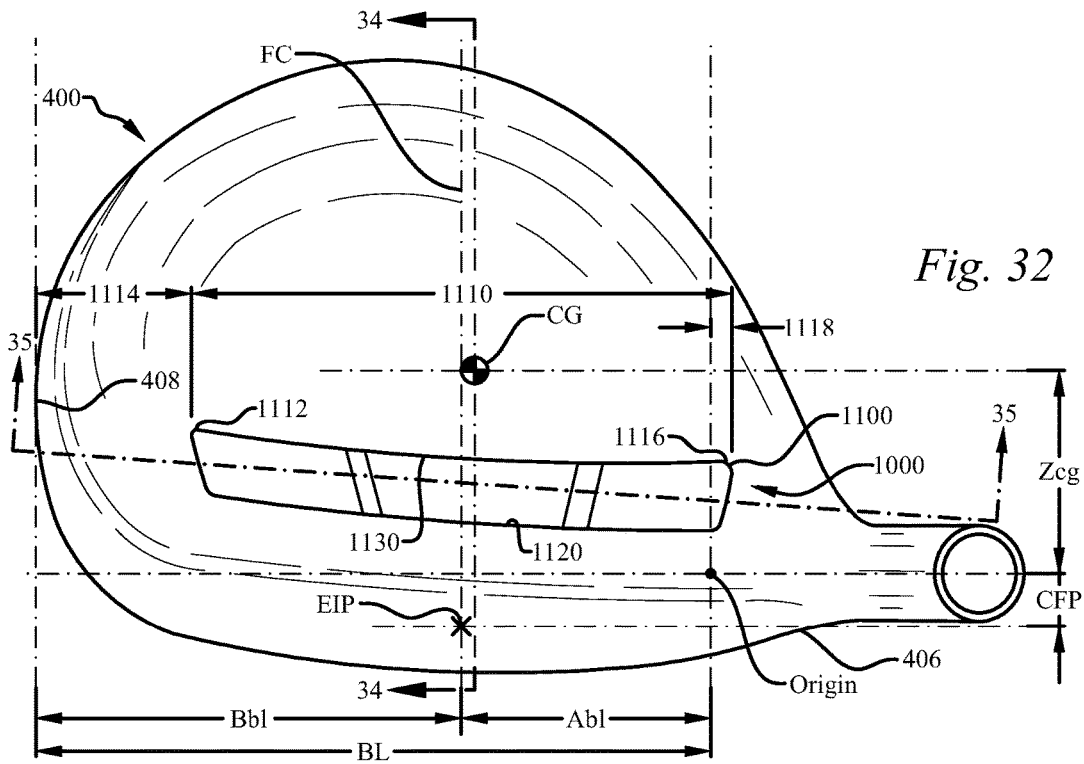

Fig. 32

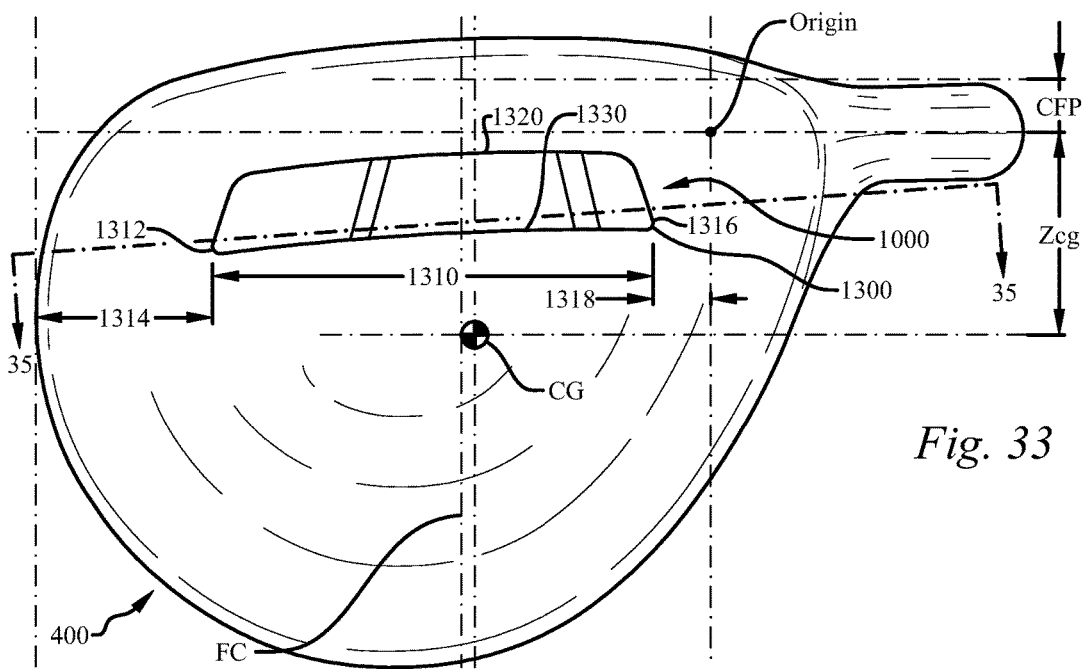

Fig. 33

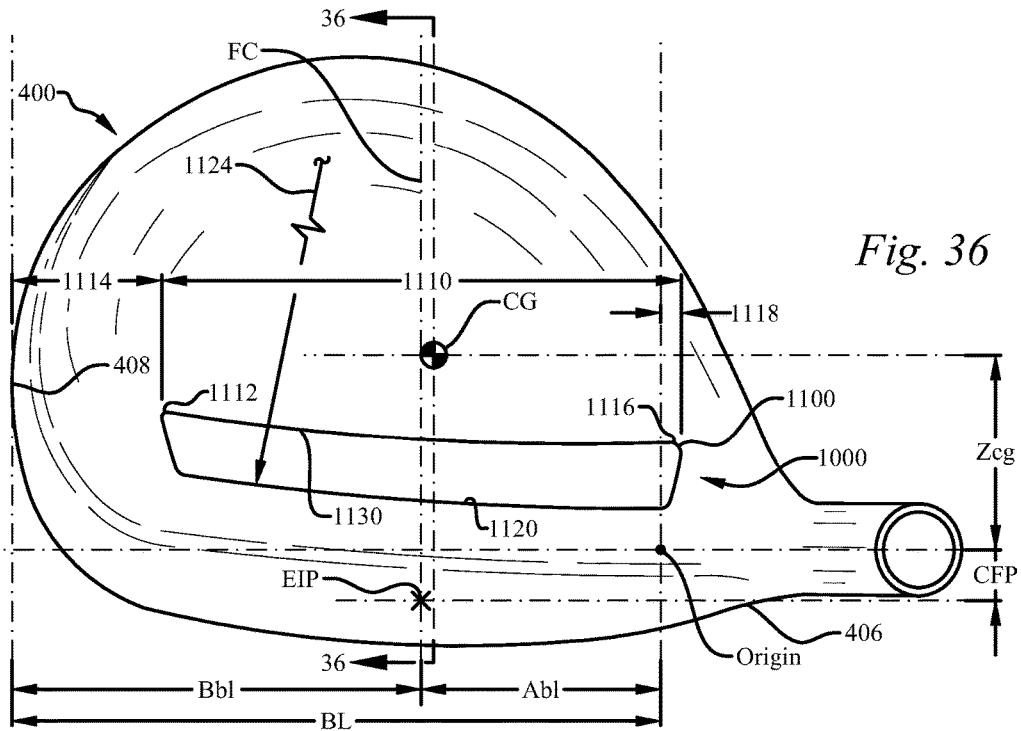

Fig. 36

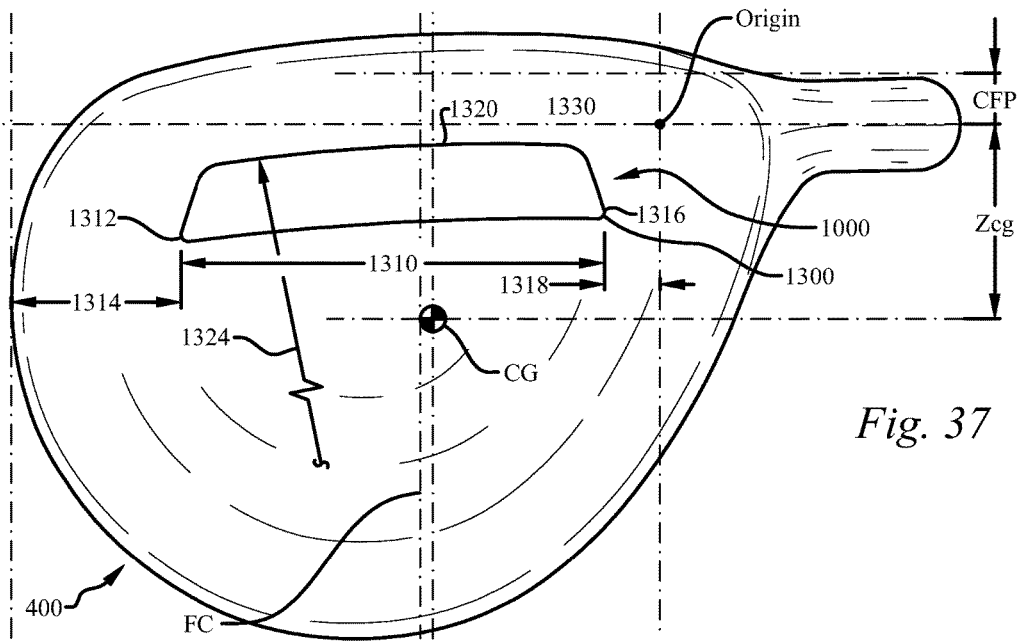

Fig. 37

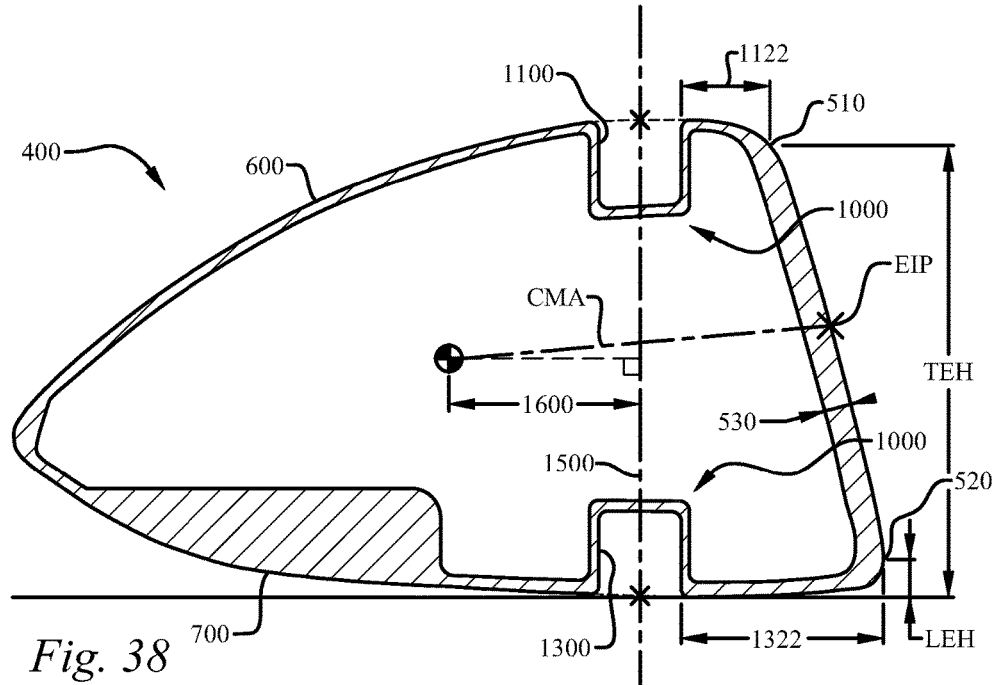

Fig. 38

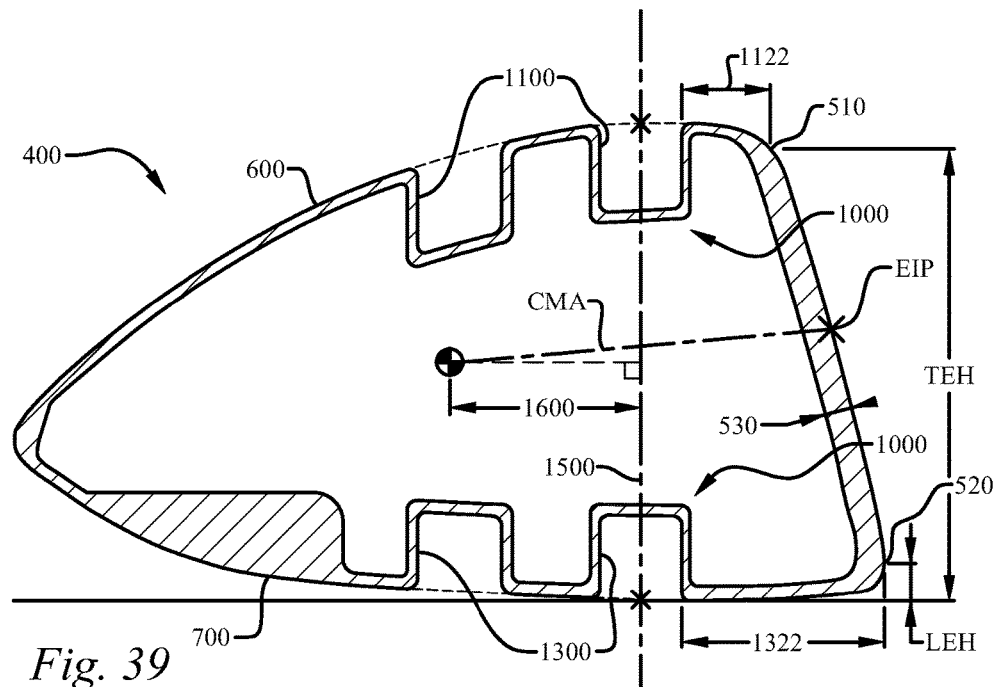

Fig. 39

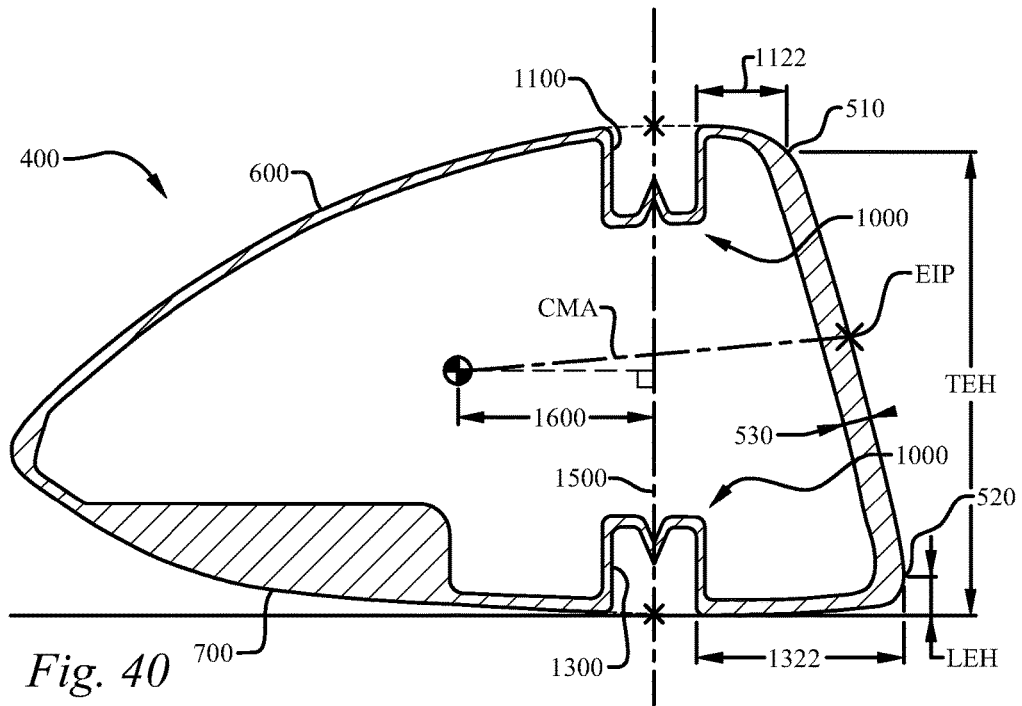

Fig. 40

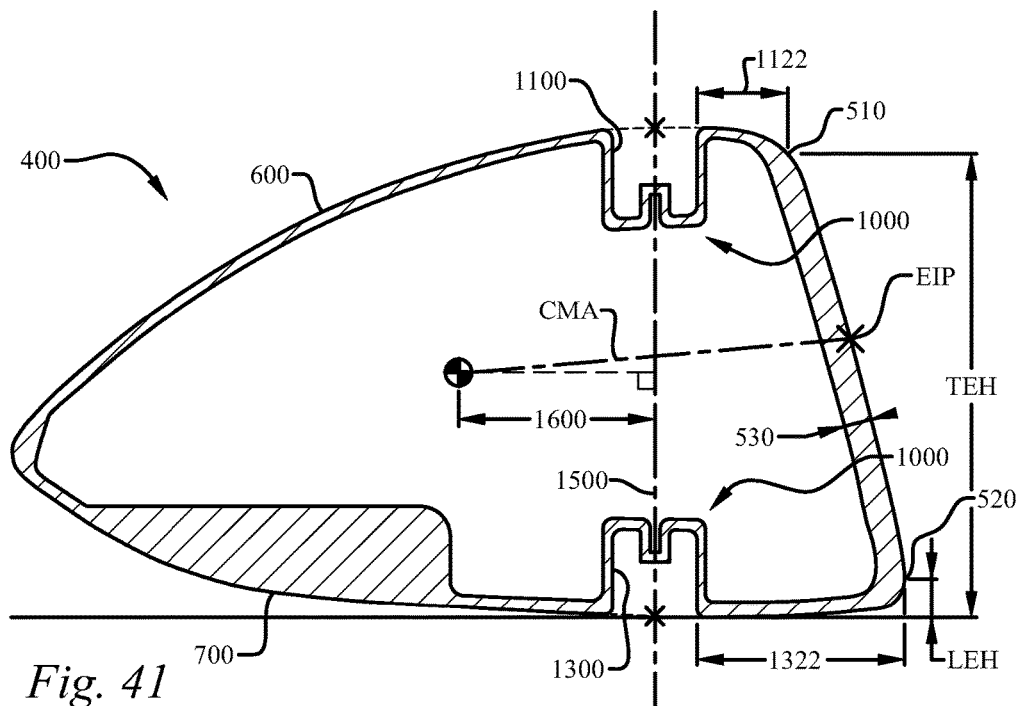

Fig. 41

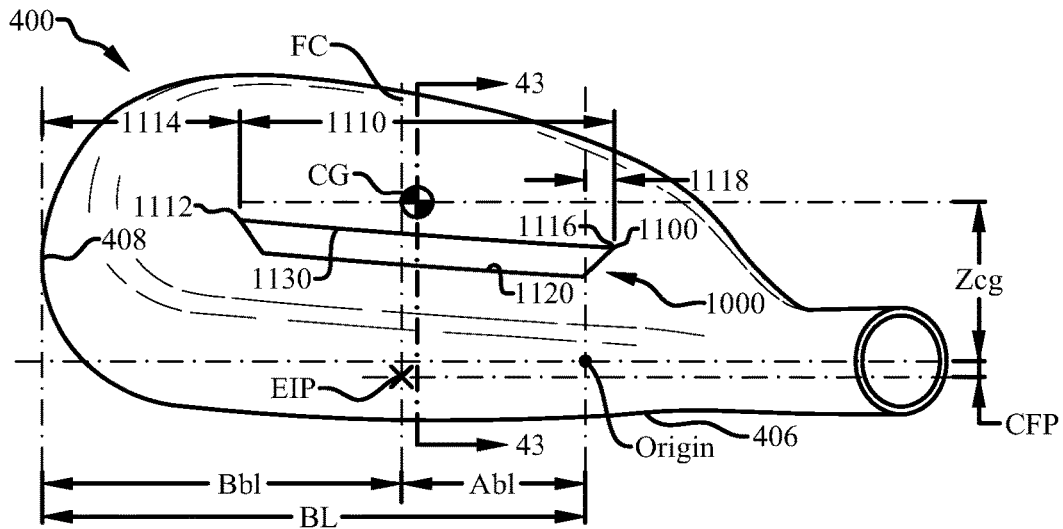

Fig. 42

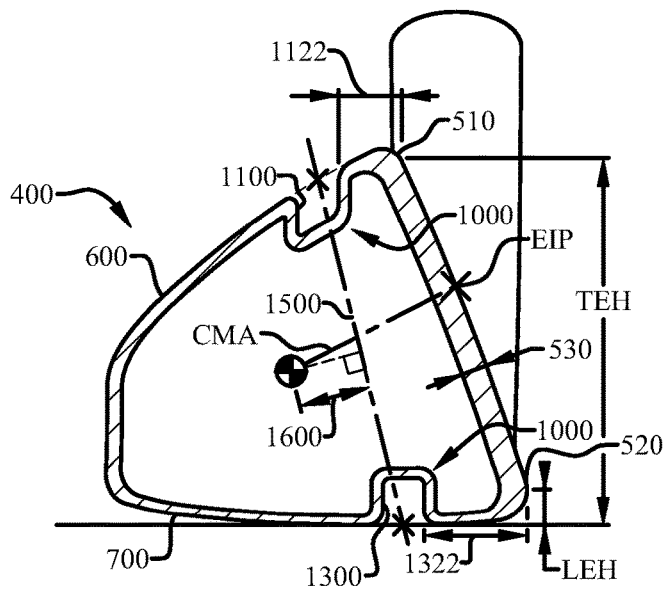

Fig. 43

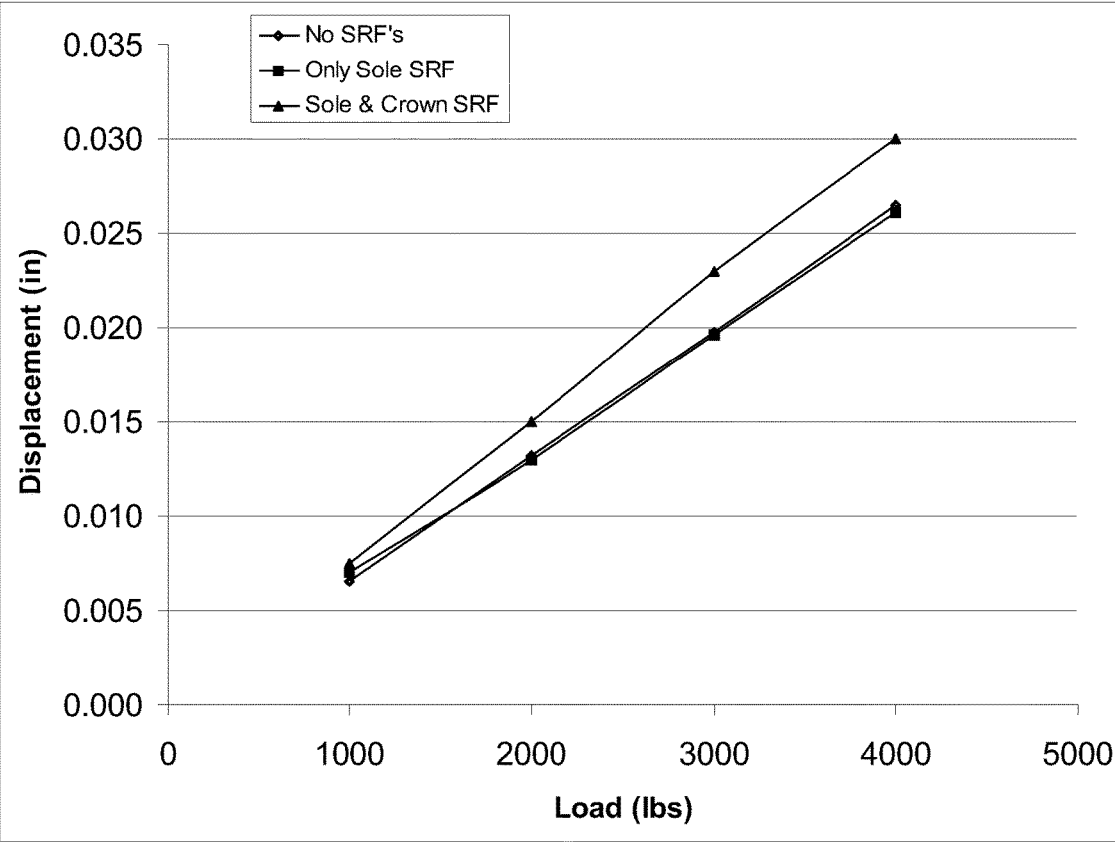

Fig. 44

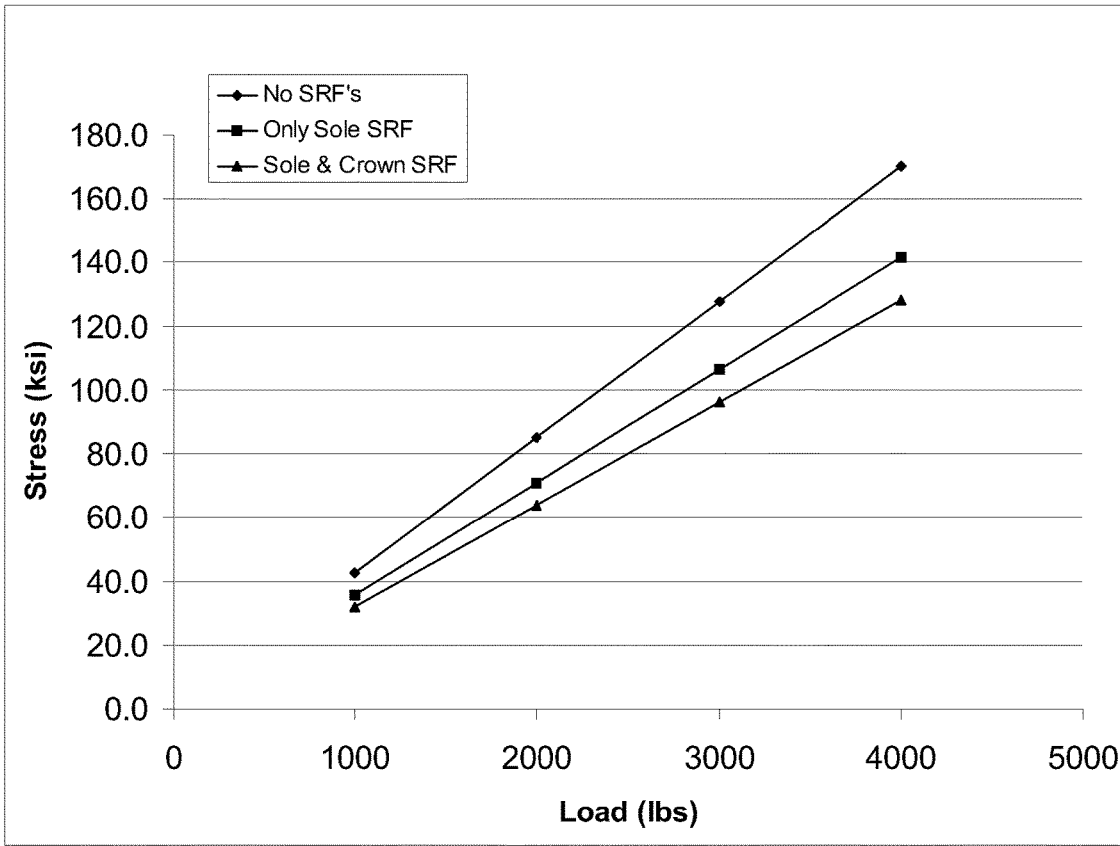

Fig. 45

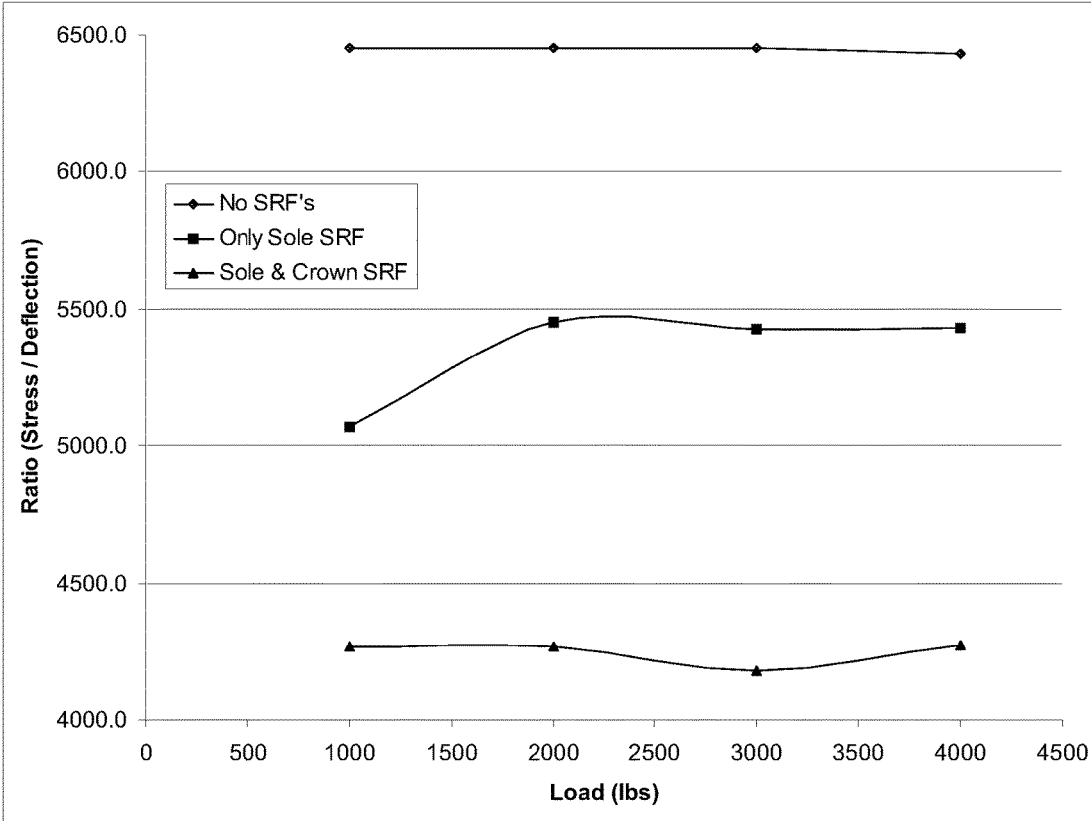

Fig. 46

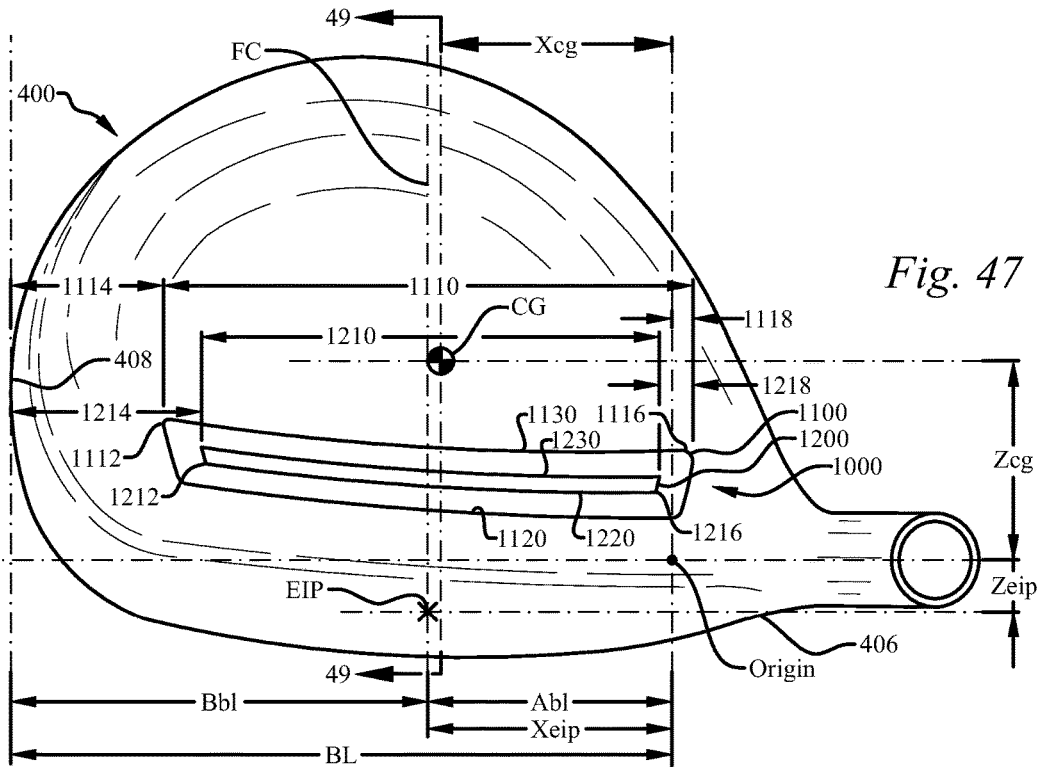

Fig. 47

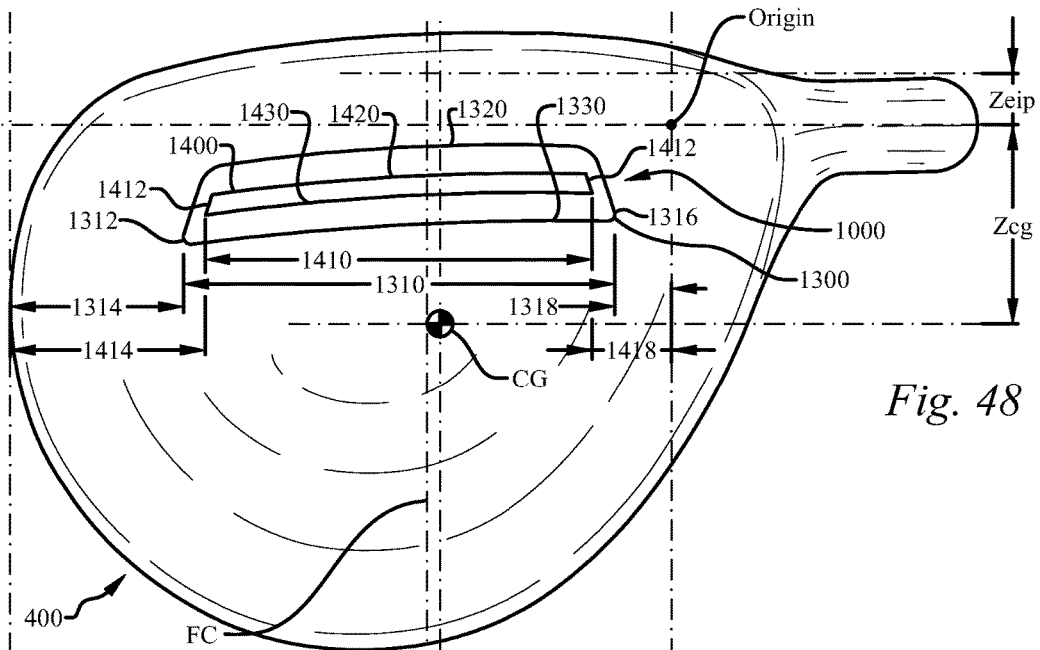
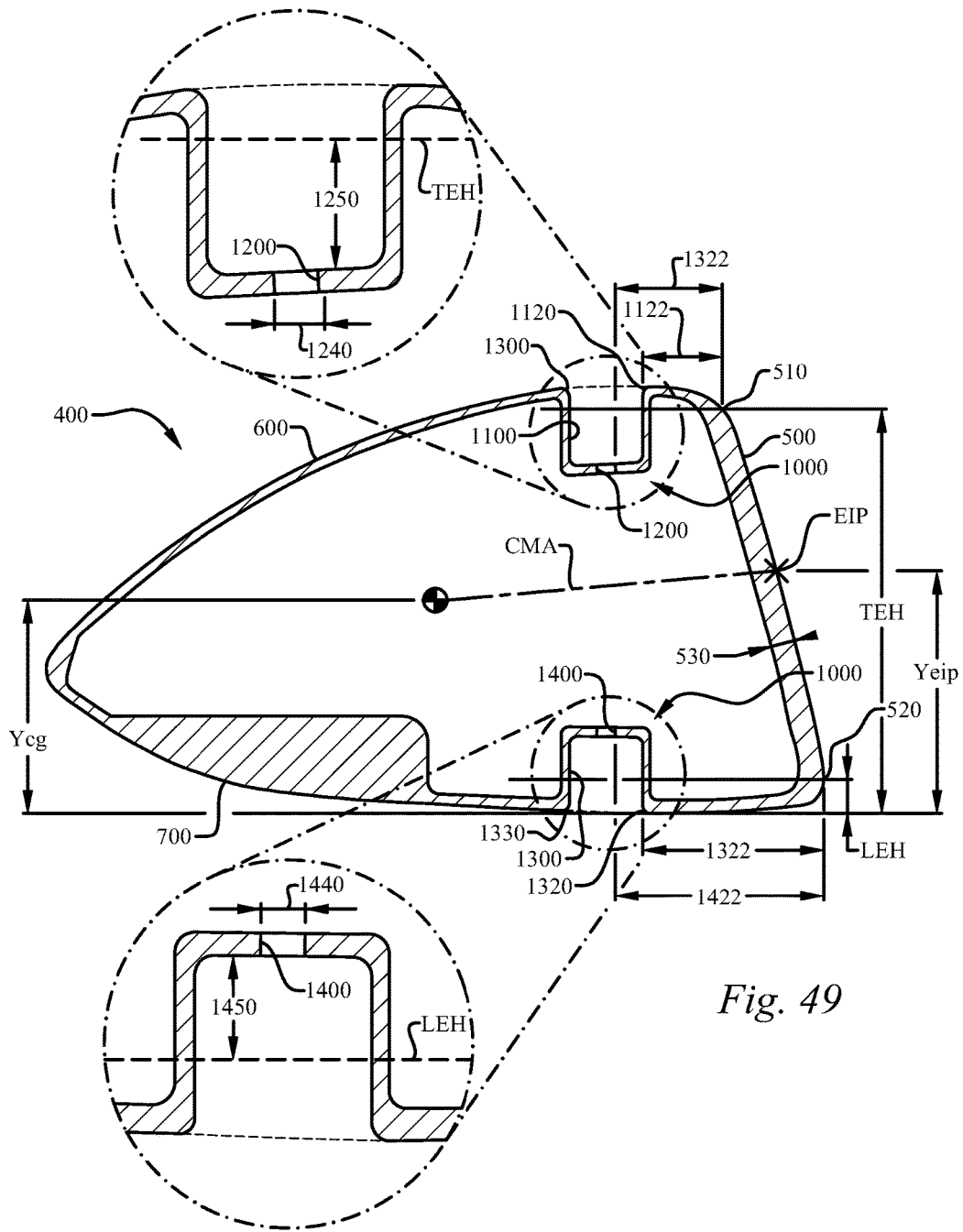
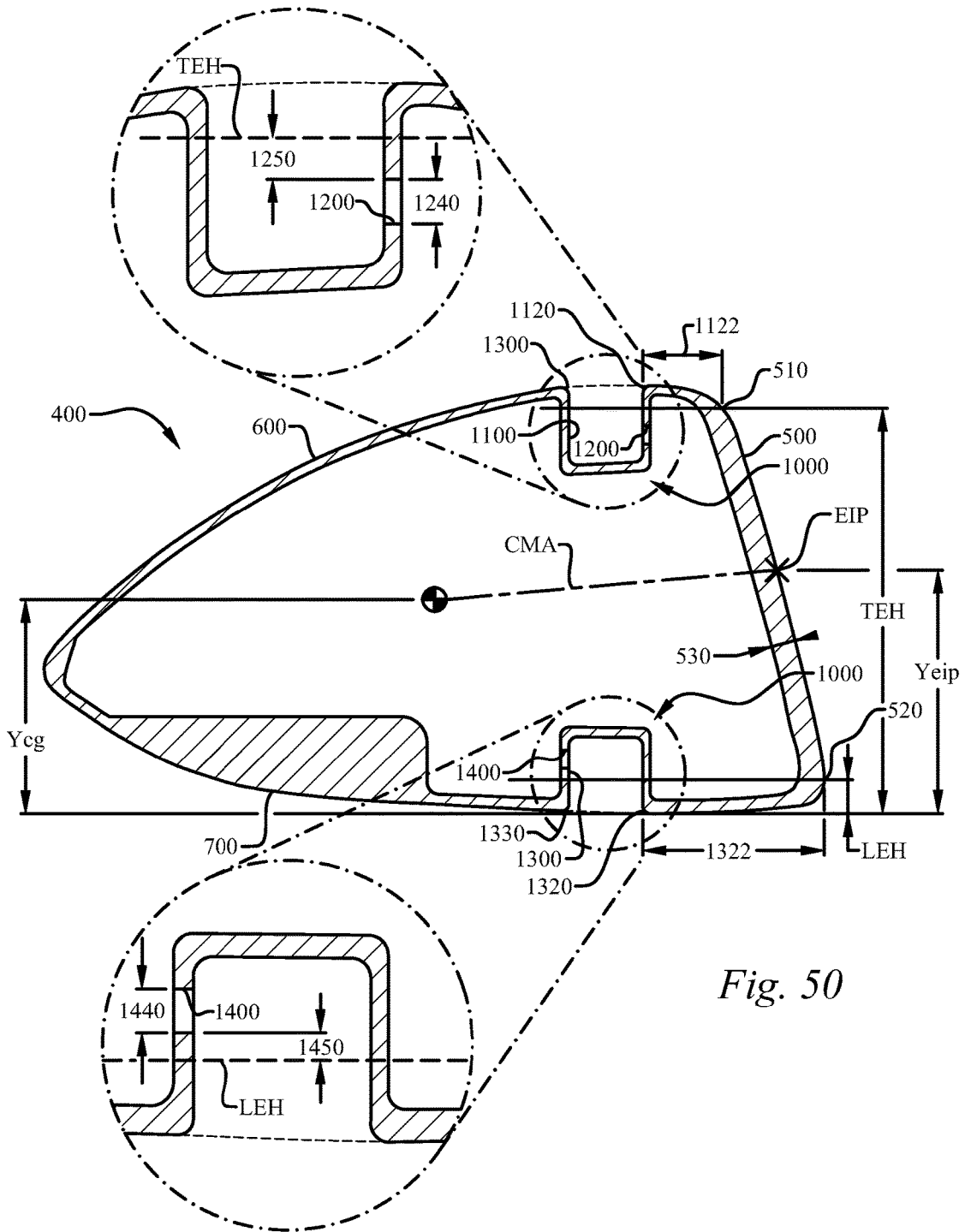

Fig. 48





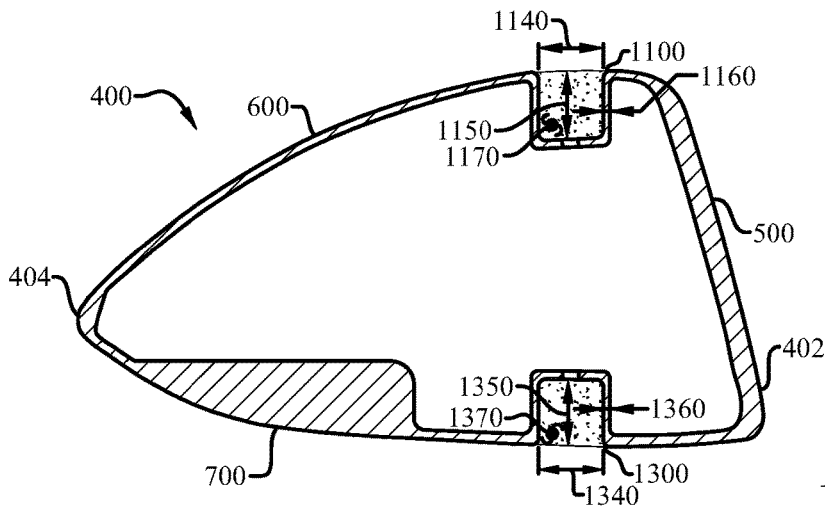

Fig. 51

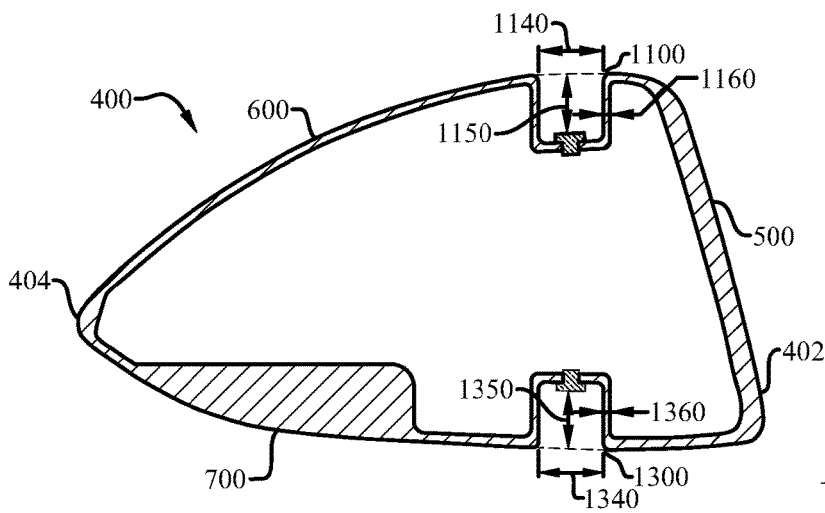

Fig. 52

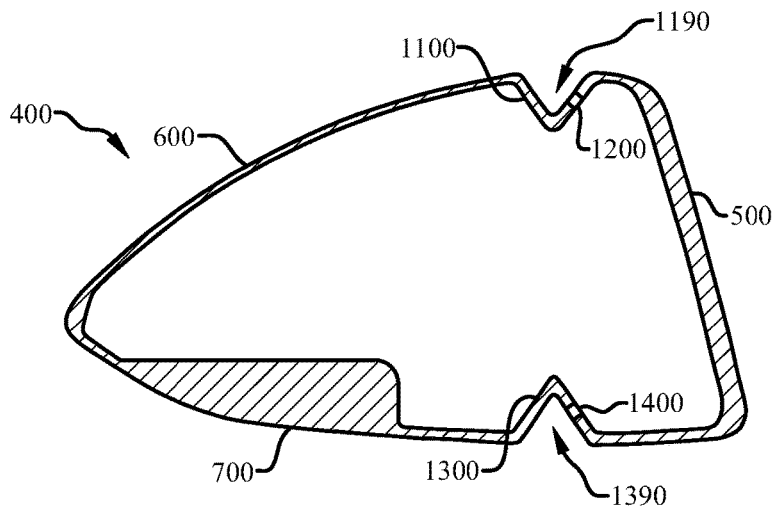

Fig. 53

1

**GOLF CLUB HEAD HAVING A STRESS
REDUCING FEATURE WITH APERTURE****CROSS-REFERENCE TO RELATED
APPLICATIONS**

This application is a continuation of U.S. patent application Ser. No. 15/437,835, filed on Feb. 21, 2017, which is a continuation of U.S. patent application Ser. No. 14/868,446, filed on Sep. 29, 2015, which is a continuation of U.S. patent application Ser. No. 14/472,415, filed on Aug. 29, 2014, now U.S. Pat. No. 9,168,434, which is a continuation of U.S. patent application Ser. No. 13/397,122, now U.S. Pat. No. 8,821,312, filed on Feb. 15, 2012, which is a continuation-in-part of U.S. patent application Ser. No. 12/791,025, now U.S. Pat. No. 8,235,844, filed on Jun. 1, 2010, all of which is incorporated by reference as if completely written herein.

**STATEMENT REGARDING FEDERALLY
SPONSORED RESEARCH OR DEVELOPMENT**

This invention was not made as part of a federally sponsored research or development project.

TECHNICAL FIELD

The present invention relates to the field of golf clubs, namely hollow golf club heads. The present invention is a hollow golf club head characterized by a stress reducing feature that includes a stress reducing feature having an aperture.

BACKGROUND OF THE INVENTION

The impact associated with a golf club head, often moving in excess of 100 miles per hour, impacting a stationary golf ball results in a tremendous force on the face of the golf club head, and accordingly a significant stress on the face. It is desirable to reduce the peak stress experienced by the face and to selectively distribute the force of impact to other areas of the golf club head where it may be more advantageously utilized.

SUMMARY OF INVENTION

In its most general configuration, the present invention advances the state of the art with a variety of new capabilities and overcomes many of the shortcomings of prior methods in new and novel ways. In its most general sense, the present invention overcomes the shortcomings and limitations of the prior art in any of a number of generally effective configurations.

The present golf club incorporating a stress reducing feature including a crown located SRF, short for stress reducing feature, located on the crown of the club head and/or a sole located SRF located on the sole of the club head. The SRF may contain an aperture extending through the shell of the golf club head. The location and size of the SRF and aperture play a significant role in reducing the peak stress seen on the golf club's face during an impact with a golf ball, as well as selectively increasing deflection of the face.

Numerous variations, modifications, alternatives, and alterations of the various preferred embodiments, processes, and methods may be used alone or in combination with one another as will become more readily apparent to those with

2

skill in the art with reference to the following detailed description of the preferred embodiments and the accompanying figures and drawings.

5 **BRIEF DESCRIPTION OF THE DRAWINGS**

Without limiting the scope of the present invention as claimed below and referring now to the drawings and figures:

10 FIG. 1 shows a front elevation view of an embodiment of the present invention, not to scale;

FIG. 2 shows a top plan view of an embodiment of the present invention, not to scale;

15 FIG. 3 shows a front elevation view of an embodiment of the present invention, not to scale;

FIG. 4 shows a toe side elevation view of an embodiment of the present invention, not to scale;

FIG. 5 shows a top plan view of an embodiment of the present invention, not to scale;

20 FIG. 6 shows a toe side elevation view of an embodiment of the present invention, not to scale;

FIG. 7 shows a front elevation view of an embodiment of the present invention, not to scale;

25 FIG. 8 shows a toe side elevation view of an embodiment of the present invention, not to scale;

FIG. 9 shows a front elevation view of an embodiment of the present invention, not to scale;

FIG. 10 shows a front elevation view of an embodiment of the present invention, not to scale;

30 FIG. 11 shows a front elevation view of an embodiment of the present invention, not to scale;

FIG. 12 shows a front elevation view of an embodiment of the present invention, not to scale;

35 FIG. 13 shows a front elevation view of an embodiment of the present invention, not to scale;

FIG. 14 shows a top plan view of an embodiment of the present invention, not to scale;

FIG. 15 shows a front elevation view of an embodiment of the present invention, not to scale;

40 FIG. 16 shows a top plan view of an embodiment of the present invention, not to scale;

FIG. 17 shows a top plan view of an embodiment of the present invention, not to scale;

45 FIG. 18 shows a top plan view of an embodiment of the present invention, not to scale;

FIG. 19 shows a front elevation view of an embodiment of the present invention, not to scale;

FIG. 20 shows a toe side elevation view of an embodiment of the present invention, not to scale;

50 FIG. 21 shows a front elevation view of an embodiment of the present invention, not to scale;

FIG. 22 shows a top plan view of an embodiment of the present invention, not to scale;

55 FIG. 23 shows a bottom plan view of an embodiment of the present invention, not to scale;

FIG. 24 shows a partial cross-sectional view of an embodiment of the present invention, not to scale;

FIG. 25 shows a partial cross-sectional view of an embodiment of the present invention, not to scale;

60 FIG. 26 shows a partial cross-sectional view of an embodiment of the present invention, not to scale;

FIG. 27 shows a partial cross-sectional view of an embodiment of the present invention, not to scale;

65 FIG. 28 shows a partial cross-sectional view of an embodiment of the present invention, not to scale;

FIG. 29 shows a partial cross-sectional view of an embodiment of the present invention, not to scale;

FIG. 30 shows a top plan view of an embodiment of the present invention, not to scale;

FIG. 31 shows a bottom plan view of an embodiment of the present invention, not to scale;

FIG. 32 shows a top plan view of an embodiment of the present invention, not to scale;

FIG. 33 shows a bottom plan view of an embodiment of the present invention, not to scale;

FIG. 34 shows a partial cross-sectional view of an embodiment of the present invention, not to scale;

FIG. 35 shows a partial cross-sectional view of an embodiment of the present invention, not to scale;

FIG. 36 shows a top plan view of an embodiment of the present invention, not to scale;

FIG. 37 shows a bottom plan view of an embodiment of the present invention, not to scale;

FIG. 38 shows a partial cross-sectional view of an embodiment of the present invention, not to scale;

FIG. 39 shows a partial cross-sectional view of an embodiment of the present invention, not to scale;

FIG. 40 shows a partial cross-sectional view of an embodiment of the present invention, not to scale;

FIG. 41 shows a partial cross-sectional view of an embodiment of the present invention, not to scale;

FIG. 42 shows a top plan view of an embodiment of the present invention, not to scale;

FIG. 43 shows a partial cross-sectional view of an embodiment of the present invention, not to scale;

FIG. 44 shows a graph of face displacement versus load;

FIG. 45 shows a graph of peak stress on the face versus load;

FIG. 46 shows a graph of the stress-to-deflection ratio versus load;

FIG. 47 shows a top plan view of an embodiment of the present invention, not to scale;

FIG. 48 shows a bottom plan view of an embodiment of the present invention, not to scale;

FIG. 49 shows a partial cross-sectional view of an embodiment of the present invention, not to scale;

FIG. 50 shows a partial cross-sectional view of an embodiment of the present invention, not to scale;

FIG. 51 shows a partial cross-sectional view of an embodiment of the present invention, not to scale;

FIG. 52 shows a partial cross-sectional view of an embodiment of the present invention, not to scale; and

FIG. 53 shows a partial cross-sectional view of an embodiment of the present invention, not to scale.

These drawings are provided to assist in the understanding of the exemplary embodiments of the present golf club as described in more detail below and should not be construed as unduly limiting the golf club. In particular, the relative spacing, positioning, sizing and dimensions of the various elements illustrated in the drawings are not drawn to scale and may have been exaggerated, reduced or otherwise modified for the purpose of improved clarity. Those of ordinary skill in the art will also appreciate that a range of alternative configurations have been omitted simply to improve the clarity and reduce the number of drawings.

DETAILED DESCRIPTION OF THE INVENTION

The hollow golf club of the present invention enables a significant advance in the state of the art. The preferred embodiments of the golf club accomplish this by new and novel methods that are configured in unique and novel ways and which demonstrate previously unavailable, but preferred

and desirable capabilities. The description set forth below in connection with the drawings is intended merely as a description of the presently preferred embodiments of the golf club, and is not intended to represent the only form in which the present golf club may be constructed or utilized. The description sets forth the designs, functions, means, and methods of implementing the golf club in connection with the illustrated embodiments. It is to be understood, however, that the same or equivalent functions and features may be accomplished by different embodiments that are also intended to be encompassed within the spirit and scope of the claimed golf club head.

In order to fully appreciate the present disclosed golf club some common terms must be defined for use herein. First, one of skill in the art will know the meaning of "center of gravity," referred to herein as CG, from an entry level course on the mechanics of solids. With respect to wood-type golf clubs, hybrid golf clubs, and hollow iron type golf clubs, which are may have non-uniform density, the CG is often thought of as the intersection of all the balance points of the club head. In other words, if you balance the head on the face and then on the sole, the intersection of the two imaginary lines passing straight through the balance points would define the point referred to as the CG.

It is helpful to establish a coordinate system to identify and discuss the location of the CG. In order to establish this coordinate system one must first identify a ground plane (GP) and a shaft axis (SA). First, the ground plane (GP) is the horizontal plane upon which a golf club head rests, as seen best in a front elevation view of a golf club head looking at the face of the golf club head, as seen in FIG. 1. Secondly, the shaft axis (SA) is the axis of a bore in the golf club head that is designed to receive a shaft. Some golf club heads have an external hosel that contains a bore for receiving the shaft such that one skilled in the art can easily appreciate the shaft axis (SA), while other "hosel-less" golf clubs have an internal bore that receives the shaft that nonetheless defines the shaft axis (SA). The shaft axis (SA) is fixed by the design of the golf club head and is also illustrated in FIG. 1.

Now, the intersection of the shaft axis (SA) with the ground plane (GP) fixes an origin point, labeled "origin" in FIG. 1, for the coordinate system. While it is common knowledge in the industry, it is worth noting that the right side of the club head seen in FIG. 1, the side nearest the bore in which the shaft attaches, is the "heel" side of the golf club head; and the opposite side, the left side in FIG. 1, is referred to as the "toe" side of the golf club head. Additionally, the portion of the golf club head that actually strikes a golf ball is referred to as the face of the golf club head and is commonly referred to as the front of the golf club head; whereas the opposite end of the golf club head is referred to as the rear of the golf club head and/or the trailing edge.

A three dimensional coordinate system may now be established from the origin with the Y-direction being the vertical direction from the origin; the X-direction being the horizontal direction perpendicular to the Y-direction and wherein the X-direction is parallel to the face of the golf club head in the natural resting position, also known as the design position; and the Z-direction is perpendicular to the X-direction wherein the Z-direction is the direction toward the rear of the golf club head. The X, Y, and Z directions are noted on a coordinate system symbol in FIG. 1. It should be noted that this coordinate system is contrary to the traditional right-hand rule coordinate system; however it is preferred so that the center of gravity may be referred to as having all positive coordinates.

Now, with the origin and coordinate system defined, the terms that define the location of the CG may be explained. One skilled in the art will appreciate that the CG of a hollow golf club head such as the wood-type golf club head illustrated in FIG. 2 will be behind the face of the golf club head. The distance behind the origin that the CG is located is referred to as Z_{cg} , as seen in FIG. 2. Similarly, the distance above the origin that the CG is located is referred to as Y_{cg} , as seen in FIG. 3. Lastly, the horizontal distance from the origin that the CG is located is referred to as X_{cg} , also seen in FIG. 3. Therefore, the location of the CG may be easily identified by reference to X_{cg} , Y_{cg} , and Z_{cg} .

The moment of inertia of the golf club head is a key ingredient in the playability of the club. Again, one skilled in the art will understand what is meant by moment of inertia with respect to golf club heads; however it is helpful to define two moment of inertia components that will be commonly referred to herein. First, MOI_x is the moment of inertia of the golf club head around an axis through the CG, parallel to the X-axis, labeled in FIG. 4. MOI_x is the moment of inertia of the golf club head that resists lofting and delofting moments induced by ball strikes high or low on the face. Secondly, MOI_y is the moment of the inertia of the golf club head around an axis through the CG, parallel to the Y-axis, labeled in FIG. 5. MOI_y is the moment of inertia of the golf club head that resists opening and closing moments induced by ball strikes towards the toe side or heel side of the face.

Continuing with the definitions of key golf club head dimensions, the "front-to-back" dimension, referred to as the FB dimension, is the distance from the furthest forward point at the leading edge of the golf club head to the furthest rearward point at the rear of the golf club head, i.e. the trailing edge, as seen in FIG. 6. The "heel-to-toe" dimension, referred to as the HT dimension, is the distance from the point on the surface of the club head on the toe side that is furthest from the origin in the X-direction, to the point on the surface of the golf club head on the heel side that is 0.875" above the ground plane and furthest from the origin in the negative X-direction, as seen in FIG. 7.

A key location on the golf club face is an engineered impact point (EIP). The engineered impact point (EIP) is important in that it helps define several other key attributes of the present golf club head. The engineered impact point (EIP) is generally thought of as the point on the face that is the ideal point at which to strike the golf ball. Generally, the score lines on golf club heads enable one to easily identify the engineered impact point (EIP) for a golf club. In the embodiment of FIG. 9, the first step in identifying the engineered impact point (EIP) is to identify the top score line (TSL) and the bottom score line (BSL). Next, draw an imaginary line (IL) from the midpoint of the top score line (TSL) to the midpoint of the bottom score line (BSL). This imaginary line (IL) will often not be vertical since many score line designs are angled upward toward the toe when the club is in the natural position. Next, as seen in FIG. 10, the club must be rotated so that the top score line (TSL) and the bottom score line (BSL) are parallel with the ground plane (GP), which also means that the imaginary line (IL) will now be vertical. In this position, the leading edge height (LEH) and the top edge height (TEH) are measured from the ground plane (GP). Next, the face height is determined by subtracting the leading edge height (LEH) from the top edge height (TEH). The face height is then divided in half and added to the leading edge height (LEH) to yield the height of the engineered impact point (EIP). Continuing with the club head in the position of FIG. 10, a spot is marked on the

imaginary line (IL) at the height above the ground plane (GP) that was just calculated. This spot is the engineered impact point (EIP).

The engineered impact point (EIP) may also be easily determined for club heads having alternative score line configurations. For instance, the golf club head of FIG. 11 does not have a centered top score line. In such a situation, the two outermost score lines that have lengths within 5% of one another are then used as the top score line (TSL) and the bottom score line (BSL). The process for determining the location of the engineered impact point (EIP) on the face is then determined as outlined above. Further, some golf club heads have non-continuous score lines, such as that seen at the top of the club head face in FIG. 12. In this case, a line is extended across the break between the two top score line sections to create a continuous top score line (TSL). The newly created continuous top score line (TSL) is then bisected and used to locate the imaginary line (IL). Again, then the process for determining the location of the engineered impact point (EIP) on the face is determined as outlined above.

The engineered impact point (EIP) may also be easily determined in the rare case of a golf club head having an asymmetric score line pattern, or no score lines at all. In such embodiments the engineered impact point (EIP) shall be determined in accordance with the USGA "Procedure for Measuring the Flexibility of a Golf Clubhead," Revision 2.0, Mar. 25, 2005, which is incorporated herein by reference. This USGA procedure identifies a process for determining the impact location on the face of a golf club that is to be tested, also referred therein as the face center. The USGA procedure utilizes a template that is placed on the face of the golf club to determine the face center. In these limited cases of asymmetric score line patterns, or no score lines at all, this USGA face center shall be the engineered impact point (EIP) that is referenced throughout this application.

The engineered impact point (EIP) on the face is an important reference to define other attributes of the present golf club head. The engineered impact point (EIP) is generally shown on the face with rotated crosshairs labeled EIP. The precise location of the engineered impact point (EIP) can be identified via the dimensions X_{eip} , Y_{eip} , and Z_{eip} , as illustrated in FIGS. 22-24. The X coordinate X_{eip} is measured in the same manner as X_{cg} , the Y coordinate Y_{eip} is measured in the same manner as Y_{cg} , and the Z coordinate Z_{eip} is measured in the same manner as Z_{cg} , except that Z_{eip} is always a positive value regardless of whether it is in front of the origin point or behind the origin point.

One important dimension that utilizes the engineered impact point (EIP) is the center face progression (CFP), seen in FIGS. 8 and 14. The center face progression (CFP) is a single dimension measurement and is defined as the distance in the Z-direction from the shaft axis (SA) to the engineered impact point (EIP). A second dimension that utilizes the engineered impact point (EIP) is referred to as a club moment arm (CMA). The CMA is the two dimensional distance from the CG of the club head to the engineered impact point (EIP) on the face, as seen in FIG. 8. Thus, with reference to the coordinate system shown in FIG. 1, the club moment arm (CMA) includes a component in the Z-direction and a component in the Y-direction, but ignores any difference in the X-direction between the CG and the engineered impact point (EIP). Thus, the club moment arm (CMA) can be thought of in terms of an impact vertical plane passing through the engineered impact point (EIP) and extending in the Z-direction. First, one would translate the CG horizontally in the X-direction until it hits the impact

vertical plane. Then, the club moment arm (CMA) would be the distance from the projection of the CG on the impact vertical plane to the engineered impact point (EIP). The club moment arm (CMA) has a significant impact on the launch angle and the spin of the golf ball upon impact.

Another important dimension in golf club design is the club head blade length (BL), seen in FIG. 13 and FIG. 14. The blade length (BL) is the distance from the origin to a point on the surface of the club head on the toe side that is furthest from the origin in the X-direction. The blade length (BL) is composed of two sections, namely the heel blade length section (Abl) and the toe blade length section (Bbl). The point of delineation between these two sections is the engineered impact point (EIP), or more appropriately, a vertical line, referred to as a face centerline (FC), extending through the engineered impact point (EIP), as seen in FIG. 13, when the golf club head is in the normal resting position, also referred to as the design position.

Further, several additional dimensions are helpful in understanding the location of the CG with respect to other points that are essential in golf club engineering. First, a CG angle (CGA) is the one dimensional angle between a line connecting the CG to the origin and an extension of the shaft axis (SA), as seen in FIG. 14. The CG angle (CGA) is measured solely in the X-Z plane and therefore does not account for the elevation change between the CG and the origin, which is why it is easiest understood in reference to the top plan view of FIG. 14.

Lastly, another important dimension in quantifying the present golf club only takes into consideration two dimensions and is referred to as the transfer distance (TD), seen in FIG. 17. The transfer distance (TD) is the horizontal distance from the CG to a vertical line extending from the origin; thus, the transfer distance (TD) ignores the height of the CG, or Ycg. Thus, using the Pythagorean Theorem from simple geometry, the transfer distance (TD) is the hypotenuse of a right triangle with a first leg being Xcg and the second leg being Zcg.

The transfer distance (TD) is significant in that it helps define another moment of inertia value that is significant to the present golf club. This new moment of inertia value is defined as the face closing moment of inertia, referred to as MOIfc, which is the horizontally translated (no change in Y-direction elevation) version of MOIy around a vertical axis that passes through the origin. MOIfc is calculated by adding MOIy to the product of the club head mass and the transfer distance (TD) squared. Thus,

$$MOIfc=MOIy+(mass*(TD)^2)$$

The face closing moment (MOIfc) is important because it represents the resistance that a golfer feels during a swing when trying to bring the club face back to a square position for impact with the golf ball. In other words, as the golf swing returns the golf club head to its original position to impact the golf ball the face begins closing with the goal of being square at impact with the golf ball.

The presently disclosed hollow golf club incorporates stress reducing features unlike prior hollow type golf clubs. The hollow type golf club includes a shaft (200) having a proximal end (210) and a distal end (220); a grip (300) attached to the shaft proximal end (210); and a golf club head (100) attached at the shaft distal end (220), as seen in FIG. 21. The overall hollow type golf club has a club length of at least 36 inches and no more than 45 inches, as measure in accordance with USGA guidelines.

The golf club head (400) itself is a hollow structure that includes a face (500) positioned at a front portion (402) of

the golf club head (400) where the golf club head (400) impacts a golf ball, a sole (700) positioned at a bottom portion of the golf club head (400), a crown (600) positioned at a top portion of the golf club head (400), and a skirt (800) positioned around a portion of a periphery of the golf club head (400) between the sole (700) and the crown (800). The face (500), sole (700), crown (600), and skirt (800) define an outer shell that further defines a head volume that is less than 300 cubic centimeters for the golf club head (400). Additionally, the golf club head (400) has a rear portion (404) opposite the face (500). The rear portion (404) includes the trailing edge of the golf club head (400), as is understood by one with skill in the art. The face (500) has a loft (L) of at least 12 degrees and no more than 30 degrees, and the face (500) includes an engineered impact point (EIP) as defined above. One skilled in the art will appreciate that the skirt (800) may be significant at some areas of the golf club head (400) and virtually nonexistent at other areas; particularly at the rear portion (404) of the golf club head (400) where it is not uncommon for it to appear that the crown (600) simply wraps around and becomes the sole (700).

The golf club head (100) includes a bore having a center that defines a shaft axis (SA) that intersects with a horizontal ground plane (GP) to define an origin point, as previously explained. The bore is located at a heel side (406) of the golf club head (400) and receives the shaft distal end (220) for attachment to the golf club head (400). The golf club head (100) also has a toe side (408) located opposite of the heel side (406). The presently disclosed golf club head (400) has a club head mass of less than 270 grams, which combined with the previously disclosed loft, club head volume, and club length establish that the presently disclosed golf club is directed to a hollow golf club such as a fairway wood, hybrid, or hollow iron.

The golf club head (400) may include a stress reducing feature (1000) including a crown located SRF (1100) located on the crown (600), seen in FIG. 22, and/or a sole located SRF (1300) located on the sole (700), seen in FIG. 23. As seen in FIGS. 22 and 25, the crown located SRF (1100) has a CSRF length (1110) between a CSRF toe-most point (1112) and a CSRF heel-most point (1116), a CSRF leading edge (1120), a CSRF trailing edge (1130), a CSRF width (1140), and a CSRF depth (1150). Similarly, as seen in FIGS. 23 and 25, the sole located SRF (1300) has a SSRF length (1310) between a SSRF toe-most point (1312) and a SSRF heel-most point (1316), a SSRF leading edge (1320), a SSRF trailing edge (1330), a SSRF width (1340), and a SSRF depth (1350).

With reference now to FIG. 24, in embodiments which incorporate both a crown located SRF (1100) and a sole located SRF (1300), a SRF connection plane (1500) passes through a portion of the crown located SRF (1100) and the sole located SRF (1300). To locate the SRF connection plane (1500) a vertical section is taken through the club head (400) in a front-to-rear direction, perpendicular to a vertical plane created by the shaft axis (SA); such a section is seen in FIG. 24. Then a crown SRF midpoint of the crown located SRF (1100) is determined at a location on a crown imaginary line following the natural curvature of the crown (600). The crown imaginary line is illustrated in FIG. 24 with a broken, or hidden, line connecting the CSRF leading edge (1120) to the CSRF trailing edge (1130), and the crown SRF midpoint is illustrated with an X. Similarly, a sole SRF midpoint of the sole located SRF (1300) is determined at a location on a sole imaginary line following the natural curvature of the sole (700). The sole imaginary line is illustrated in FIG. 24 with a broken, or hidden, line connecting the SSRF leading edge

(1320) to the SSRF trailing edge (1330), and the sole SRF midpoint is illustrated with an X. Finally, the SRF connection plane (1500) is a plane in the heel-to-toe direction that passes through both the crown SRF midpoint and the sole SRF midpoint, as seen in FIG. 24. While the SRF connection plane (1500) illustrated in FIG. 24 is approximately vertical, the orientation of the SRF connection plane (1500) depends on the locations of the crown located SRF (1100) and the sole located SRF (1300) and may be angled toward the face, as seen in FIG. 26, or angled away from the face, as seen in FIG. 27.

The SRF connection plane (1500) is oriented at a connection plane angle (1510) from the vertical, seen in FIGS. 26 and 27, which aids in defining the location of the crown located SRF (1100) and the sole located SRF (1300). In one particular embodiment the crown located SRF (1100) and the sole located SRF (1300) are not located vertically directly above and below one another; rather, the connection plane angle (1510) is greater than zero and less than ninety percent of a loft (L) of the club head (400), as seen in FIG. 26. The sole located SRF (1300) could likewise be located in front of, i.e. toward the face (500), the crown located SRF (1100) and still satisfy the criteria of this embodiment; namely, that the connection plane angle (1510) is greater than zero and less than ninety percent of a loft of the club head (400).

In an alternative embodiment, seen in FIG. 27, the SRF connection plane (1500) is oriented at a connection plane angle (1510) from the vertical and the connection plane angle (1510) is at least ten percent greater than a loft (L) of the club head (400). The crown located SRF (1100) could likewise be located in front of, i.e. toward the face (500), the sole located SRF (1300) and still satisfy the criteria of this embodiment; namely, that the connection plane angle (1510) is at least ten percent greater than a loft (L) of the club head (400). In an even further embodiment the SRF connection plane (1500) is oriented at a connection plane angle (1510) from the vertical and the connection plane angle (1510) is at least fifty percent greater than a loft (L) of the club head (400), but less than one hundred percent greater than the loft (L). These three embodiments recognize a unique relationship between the crown located SRF (1100) and the sole located SRF (1300) such that they are not vertically aligned with one another, while also not merely offset in a manner matching the loft (L) of the club head (400).

With reference now to FIGS. 30 and 31, in the event that a crown located SRF (1100) or a sole located SRF (1300), or both, do not exist at the location of the CG section, labeled as section 24-24 in FIG. 22, then the crown located SRF (1100) located closest to the front-to-rear vertical plane passing through the CG is selected. For example, as seen in FIG. 30 the right crown located SRF (1100) is nearer to the front-to-rear vertical CG plane than the left crown located SRF (1100). In other words the illustrated distance "A" is smaller for the right crown located SRF (1100). Next, the face centerline (FC) is translated until it passes through both the CSRFF leading edge (1120) and the CSRFF trailing edge (1130), as illustrated by broken line "B". Then, the midpoint of line "B" is found and labeled "C". Finally, imaginary line "D" is created that is perpendicular to the "B" line.

The same process is repeated for the sole located SRF (1300), as seen in FIG. 31. It is simply a coincidence that both the crown located SRF (1100) and the sole located SRF (1300) located closest to the front-to-rear vertical CG plane are both on the heel side (406) of the golf club head (400). The same process applies even when the crown located SRF (1100) and the sole located SRF (1300) located closest to the

front-to-rear vertical CG plane are on opposite sides of the golf club head (400). Now, still referring to FIG. 31, the process first involves identifying that the right sole located SRF (1300) is nearer to the front-to-rear vertical CG plane than the left sole located SRF (1300). In other words the illustrated distance "E" is smaller for the heel-side sole located SRF (1300). Next, the face centerline (FC) is translated until it passes through both the SSRFF leading edge (1320) and the SSRFF trailing edge (1330), as illustrated by broken line "F". Then, the midpoint of line "F" is found and labeled "G". Finally, imaginary line "H" is created that is perpendicular to the "F" line. The plane passing through both the imaginary line "D" and imaginary line "H" is the SRF connection plane (1500).

Next, referring back to FIG. 24, a CG-to-plane offset (1600) is defined as the shortest distance from the center of gravity (CG) to the SRF connection plane (1500), regardless of the location of the CG. In one particular embodiment the CG-to-plane offset (1600) is at least twenty-five percent less than the club moment arm (CMA) and the club moment arm (CMA) is less than 1.3 inches. The locations of the crown located SRF (1100) and the sole located SRF (1300) described herein, and the associated variables identifying the location, are selected to preferably reduce the stress in the face (500) when impacting a golf ball while accommodating temporary flexing and deformation of the crown located SRF (1100) and sole located SRF (1300) in a stable manner in relation to the CG location, and/or origin point, while maintaining the durability of the face (500), the crown (600), and the sole (700). Experimentation and modeling has shown that the crown located SRF (1100) and the sole located SRF (1300) increase the deflection of the face (500), while also reduce the peak stress on the face (500) at impact with a golf ball. This reduction in stress allows a substantially thinner face to be utilized, permitting the weight savings to be distributed elsewhere in the club head (400). Further, the increased deflection of the face (500) facilitates improvements in the coefficient of restitution (COR) of the club head (400), particularly for club heads having a volume of 300 cc or less.

In fact, further embodiments even more precisely identify the location of the crown located SRF (1100) and/or the sole located SRF (1300) to achieve these objectives. For instance, in one further embodiment the CG-to-plane offset (1600) is at least twenty-five percent of the club moment arm (CMA) and less than seventy-five percent of the club moment arm (CMA). In still a further embodiment, the CG-to-plane offset (1600) is at least forty percent of the club moment arm (CMA) and less than sixty percent of the club moment arm (CMA).

Alternatively, another embodiment relates the location of the crown located SRF (1100) and/or the sole located SRF (1300) to the difference between the maximum top edge height (TEH) and the minimum lower edge (LEH), referred to as the face height, rather than utilizing the CG-to-plane offset (1600) variable as previously discussed to accommodate embodiments in which a single SRF is present. As such, two additional variables are illustrated in FIG. 24, namely the CSRFF leading edge offset (1122) and the SSRFF leading edge offset (1322). The CSRFF leading edge offset (1122) is the distance from any point along the CSRFF leading edge (1120) directly forward, in the Zcg direction, to the point at the top edge (510) of the face (500). Thus, the CSRFF leading edge offset (1122) may vary along the length of the CSRFF leading edge (1120), or it may be constant if the curvature of the CSRFF leading edge (1120) matches the curvature of the top edge (510) of the face (500). Nonetheless, there will

always be a minimum CSRFB leading edge offset (1122) at the point along the CSRFB leading edge (1120) that is the closest to the corresponding point directly in front of it on the face top edge (510), and there will be a maximum CSRFB leading edge offset (1122) at the point along the CSRFB leading edge (1120) that is the farthest from the corresponding point directly in front of it on the face top edge (510). Likewise, the SSRFB leading edge offset (1322) is the distance from any point along the SSRFB leading edge (1320) directly forward, in the Zcg direction, to the point at the lower edge (520) of the face (500). Thus, the SSRFB leading edge offset (1322) may vary along the length of the SSRFB leading edge (1320), or it may be constant if the curvature of SSRFB leading edge (1320) matches the curvature of the lower edge (520) of the face (500). Nonetheless, there will always be a minimum SSRFB leading edge offset (1322) at the point along the SSRFB leading edge (1320) that is the closest to the corresponding point directly in front of it on the face lower edge (520), and there will be a maximum SSRFB leading edge offset (1322) at the point along the SSRFB leading edge (1320) that is the farthest from the corresponding point directly in front of it on the face lower edge (520). Generally, the maximum CSRFB leading edge offset (1122) and the maximum SSRFB leading edge offset (1322) will be less than seventy-five percent of the face height. For the purposes of this application and ease of definition, the face top edge (510) is the series of points along the top of the face (500) at which the vertical face roll becomes less than one inch, and similarly the face lower edge (520) is the series of points along the bottom of the face (500) at which the vertical face roll becomes less than one inch.

In this particular embodiment, the minimum CSRFB leading edge offset (1122) is less than the face height, while the minimum SSRFB leading edge offset (1322) is at least two percent of the face height. In an even further embodiment, the maximum CSRFB leading edge offset (1122) is also less than the face height. Yet another embodiment incorporates a minimum CSRFB leading edge offset (1122) that is at least ten percent of the face height, and the minimum CSRFB width (1140) is at least fifty percent of the minimum CSRFB leading edge offset (1122). A still further embodiment more narrowly defines the minimum CSRFB leading edge offset (1122) as being at least twenty percent of the face height.

Likewise, many embodiments are directed to advantageous relationships of the sole located SRF (1300). For instance, in one embodiment, the minimum SSRFB leading edge offset (1322) is at least ten percent of the face height, and the minimum SSRFB width (1340) is at least fifty percent of the minimum SSRFB leading edge offset (1322). Even further, another embodiment more narrowly defines the minimum SSRFB leading edge offset (1322) as being at least twenty percent of the face height.

Still further building upon the relationships among the CSRFB leading edge offset (1122), the SSRFB leading edge offset (1322), and the face height, one embodiment further includes an engineered impact point (EIP) having a Yeip coordinate such that the difference between Yeip and Ycg is less than 0.5 inches and greater than -0.5 inches; a Xeip coordinate such that the difference between Xeip and Xcg is less than 0.5 inches and greater than -0.5 inches; and a Zeip coordinate such that the total of Zeip and Zcg is less than 2.0 inches. These relationships among the location of the engineered impact point (EIP) and the location of the center of gravity (CG) in combination with the leading edge locations of the crown located SRF (1100) and/or the sole located SRF (1300) promote stability at impact, while accommodating desirable deflection of the SRFs (1100, 1300) and the face

(500), while also maintaining the durability of the club head (400) and reducing the peak stress experienced in the face (500).

While the location of the crown located SRF (1100) and/or the sole located SRF (1300) is important in achieving these objectives, the size of the crown located SRF (1100) and the sole located SRF (1300) also plays a role. In one particular long blade length embodiment directed to fairway wood type golf clubs and hybrid type golf clubs, illustrated in FIGS. 42 and 43, the golf club head (400) has a blade length (BL) of at least 3.0 inches with a heel blade length section (Abl) of at least 0.8 inches. In this embodiment, preferable results are obtained when the CSRFB length (1110) is at least as great as the heel blade length section (Abl) and the maximum CSRFB depth (1150) is at least ten percent of the Ycg distance, thereby permitting adequate compression and/or flexing of the crown located SRF (1100) to significantly reduce the stress on the face (500) at impact. Similarly, in some SSRFB embodiments, preferable results are obtained when the SSRFB length (1310) is at least as great as the heel blade length section (Abl) and the maximum SSRFB depth (1350) is at least ten percent of the Ycg distance, thereby permitting adequate compression and/or flexing of the sole located SRF (1300) to significantly reduce the stress on the face (500) at impact. It should be noted at this point that the cross-sectional profile of the crown located SRF (1100) and the sole mounted SRF (1300) may include any number of shapes including, but not limited to, a box-shape, as seen in FIG. 24, a smooth U-shape, as seen in FIG. 28, and a V-shape, as seen in FIG. 29. Further, the crown located SRF (1100) and the sole located SRF (1300) may include reinforcement areas as seen in FIGS. 40 and 41 to further selectively control the deformation of the SRFs (1100, 1300). Additionally, the CSRFB length (1110) and the SSRFB length (1310) are measured in the same direction as Xcg rather than along the curvature of the SRFs (1100, 1300), if curved.

The crown located SRF (1100) has a CSRFB wall thickness (1160) and sole located SRF (1300) has a SSRFB wall thickness (1360), as seen in FIG. 25. In most embodiments the CSRFB wall thickness (1160) and the SSRFB wall thickness (1360) will be at least 0.010 inches and no more than 0.150 inches. In particular embodiment has found that having the CSRFB wall thickness (1160) and the SSRFB wall thickness (1360) in the range of ten percent to sixty percent of the face thickness (530) achieves the required durability while still providing desired stress reduction in the face (500) and deflection of the face (500). Further, this range facilitates the objectives while not have a dilutive effect, nor overly increasing the weight distribution of the club head (400) in the vicinity of the SRFs (1100, 1300).

Further, the terms maximum CSRFB depth (1150) and maximum SSRFB depth (1350) are used because the depth of the crown located SRF (1100) and the depth of the sole located SRF (1300) need not be constant; in fact, they are likely to vary, as seen in FIGS. 32-35. Additionally, the end walls of the crown located SRF (1100) and the sole located SRF (1300) need not be distinct, as seen on the right and left side of the SRFs (1100, 1300) seen in FIG. 35, but may transition from the maximum depth back to the natural contour of the crown (600) or sole (700). The transition need not be smooth, but rather may be stepwise, compound, or any other geometry. In fact, the presence or absence of end walls is not necessary in determining the bounds of the claimed golf club. Nonetheless, a criteria needs to be established for identifying the location of the CSRFB toe-most point (1112), the CSRFB heel-most point (1116), the SSRFB

toe-most point (1312), and the SSRF heel-most point (1316); thus, when not identifiable via distinct end walls, these points occur where a deviation from the natural curvature of the crown (600) or sole (700) is at least ten percent of the maximum CSRFB depth (1150) or maximum SSRFB depth (1350). In most embodiments a maximum CSRFB depth (1150) and a maximum SSRFB depth (1350) of at least 0.100 inches and no more than 0.500 inches is preferred.

The CSRFB leading edge (1120) may be straight or may include a CSRFB leading edge radius of curvature (1124), as seen in FIG. 36. Likewise, the SSRFB leading edge (1320) may be straight or may include a SSRFB leading edge radius of curvature (1324), as seen in FIG. 37. One particular embodiment incorporates both a curved CSRFB leading edge (1120) and a curved SSRFB leading edge (1320) wherein both the CSRFB leading edge radius of curvature (1124) and the SSRFB leading edge radius of curvature (1324) are within forty percent of the curvature of the bulge of the face (500). In an even further embodiment both the CSRFB leading edge radius of curvature (1124) and the SSRFB leading edge radius of curvature (1324) are within twenty percent of the curvature of the bulge of the face (500). These curvatures further aid in the controlled deflection of the face (500).

One particular embodiment, illustrated in FIGS. 32-35, has a CSRFB depth (1150) that is less at the face centerline (FC) than at a point on the toe side (408) of the face centerline (FC) and at a point on the heel side (406) of the face centerline (FC), thereby increasing the potential deflection of the face (500) at the heel side (406) and the toe side (408), where the COR is generally lower than the USGA permitted limit. In another embodiment, the crown located SRF (1100) and/or the sole located SRF (1300) have reduced depth regions, namely a CSRFB reduced depth region (1152) and a SSRFB reduced depth region (1352), as seen in FIG. 35. Each reduced depth region is characterized as a continuous region having a depth that is at least twenty percent less than the maximum depth for the particular SRF (1100, 1300). The CSRFB reduced depth region (1152) has a CSRFB reduced depth length (1154) and the SSRFB reduced depth region (1352) has a SSRFB reduced depth length (1354). In one particular embodiment, each reduced depth length (1154, 1354) is at least fifty percent of the heel blade length section (Abl). A further embodiment has the CSRFB reduced depth region (1152) and the SSRFB reduced depth region (1352) approximately centered about the face centerline (FC), as seen in FIG. 35. Yet another embodiment incorporates a design wherein the CSRFB reduced depth length (1154) is at least thirty percent of the CSRFB length (1110), and/or the SSRFB reduced depth length (1354) is at least thirty percent of the SSRFB length (1310). In addition to aiding in achieving the objectives set out above, the reduced depth regions (1152, 1352) may improve the life of the SRFs (1100, 1300) and reduce the likelihood of premature failure, while increasing the COR at desirable locations on the face (500).

As seen in FIG. 25, the crown located SRF (1100) has a CSRFB cross-sectional area (1170) and the sole located SRF (1300) has a SSRFB cross-sectional area (1370). The cross-sectional areas are measured in cross-sections that run from the front portion (402) to the rear portion (404) of the club head (400) in a vertical plane. Just as the cross-sectional profiles (1190, 1390) of FIGS. 28 and 29 may change throughout the CSRFB length (1110) and the SSRFB length (1310), the CSRFB cross-sectional area (1170) and/or the SSRFB cross-sectional area (1370) may also vary along the lengths (1110, 1310). In fact, in one particular embodiment, the CSRFB cross-sectional area (1170) is less at the face

centerline (FC) than at a point on the toe side (408) of the face centerline (FC) and a point on the heel side (406) of the face centerline (FC). Similarly, in another embodiment, the SSRFB cross-sectional area (1370) is less at the face centerline than at a point on the toe side (408) of the face centerline (FC) and a point on the heel side (406) of the face centerline (FC); and yet a third embodiment incorporates both of the prior two embodiments related to the CSRFB cross-sectional area (1170) and the SSRFB cross-sectional area (1370). In one particular embodiment, the CSRFB cross-sectional area (1170) and/or the SSRFB cross-sectional area (1370) fall within the range of 0.005 square inches to 0.375 square inches. Additionally, the crown located SRF (1100) has a CSRFB volume and the sole located SRF (1300) has a SSRFB volume. In one embodiment the combined CSRFB volume and SSRFB volume is at least 0.5 percent of the club head volume and less than 10 percent of the club head volume, as this range facilitates the objectives while not have a dilutive effect, nor overly increasing the weight distribution of the club head (400) in the vicinity of the SRFs (1100, 1300). In yet another embodiment directed to single SRF variations, the individual volume of the CSRFB volume or the SSRFB volume is preferably at least 1 percent of the club head volume and less than 5 percent of the club head volume to facilitate the objectives while not have a dilutive effect, nor overly increasing the weight distribution of the club head (400) in the vicinity of the SRFs (1100, 1300). The volumes discussed above are not meant to limit the SRFs (1100, 1300) to being hollow channels, for instance the volumes discussed will still exist even if the SRFs (1100, 1300) are subsequently filled with a secondary material, as seen in FIG. 51, or covered, such that the volume is not visible to a golfer. The secondary material should be elastic, have a compressive strength less than half of the compressive strength of the outer shell, and a density less than 3 g/cm³.

Now, in another separate embodiment seen in FIGS. 36 and 37, a CSRFB origin offset (1118) is defined as the distance from the origin point to the CSRFB heel-most point (1116) in the same direction as the Xcg distance such that the CSRFB origin offset (1118) is a positive value when the CSRFB heel-most point (1116) is located toward the toe side (408) of the golf club head (400) from the origin point, and the CSRFB origin offset (1118) is a negative value when the CSRFB heel-most point (1116) is located toward the heel side (406) of the golf club head (400) from the origin point. Similarly, in this embodiment, a SSRFB origin offset (1318) is defined as the distance from the origin point to the SSRFB heel-most point (1316) in the same direction as the Xcg distance such that the SSRFB origin offset (1318) is a positive value when the SSRFB heel-most point (1316) is located toward the toe side (408) of the golf club head (400) from the origin point, and the SSRFB origin offset (1318) is a negative value when the SSRFB heel-most point (1316) is located toward the heel side (406) of the golf club head (400) from the origin point.

In one particular embodiment, seen in FIG. 37, the SSRFB origin offset (1318) is a positive value, meaning that the SSRFB heel-most point (1316) stops short of the origin point. Further, yet another separate embodiment is created by combining the embodiment illustrated in FIG. 36 wherein the CSRFB origin offset (1118) is a negative value, in other words the CSRFB heel-most point (1116) extends past the origin point, and the magnitude of the CSRFB origin offset (1118) is at least five percent of the heel blade length section (Abl). However, an alternative embodiment incorporates a CSRFB heel-most point (1116) that does not extend past the origin point and therefore the CSRFB origin offset (1118) is a

positive value with a magnitude of at least five percent of the heel blade length section (Abl). In these particular embodiments, locating the CSRF heel-most point (1116) and the SSRF heel-most point (1316) such that they are no closer to the origin point than five percent of the heel blade length section (Abl) is desirable in achieving many of the objectives discussed herein over a wide range of ball impact locations.

Still further embodiments incorporate specific ranges of locations of the CSRF toe-most point (1112) and the SSRF toe-most point (1312) by defining a CSRF toe offset (1114) and a SSRF toe offset (1314), as seen in FIGS. 36 and 37. The CSRF toe offset (1114) is the distance measured in the same direction as the Xcg distance from the CSRF toe-most point (1112) to the most distant point on the toe side (408) of golf club head (400) in this direction, and likewise the SSRF toe offset (1314) is the distance measured in the same direction as the Xcg distance from the SSRF toe-most point (1312) to the most distant point on the toe side (408) of golf club head (400) in this direction. One particular embodiment found to produce preferred face stress distribution and compression and flexing of the crown located SRF (1100) and the sole located SRF (1300) incorporates a CSRF toe offset (1114) that is at least fifty percent of the heel blade length section (Abl) and a SSRF toe offset (1314) that is at least fifty percent of the heel blade length section (Abl). In yet a further embodiment the CSRF toe offset (1114) and the SSRF toe offset (1314) are each at least fifty percent of a golf ball diameter; thus, the CSRF toe offset (1114) and the SSRF toe offset (1314) are each at 0.84 inches. These embodiments also minimally affect the integrity of the club head (400) as a whole, thereby ensuring the desired durability, particularly at the heel side (406) and the toe side (408) while still allowing for improved face deflection during off center impacts.

Even more embodiments now turn the focus to the size of the crown located SRF (1100) and the sole located SRF (1300). One such embodiment has a maximum CSRF width (1140) that is at least ten percent of the Zcg distance, and the maximum SSRF width (1340) is at least ten percent of the Zcg distance, further contributing to increased stability of the club head (400) at impact. Still further embodiments increase the maximum CSRF width (1140) and the maximum SSRF width (1340) such that they are each at least forty percent of the Zcg distance, thereby promoting deflection and selectively controlling the peak stresses seen on the face (500) at impact. An alternative embodiment relates the maximum CSRF depth (1150) and the maximum SSRF depth (1350) to the face height rather than the Zcg distance as discussed above. For instance, yet another embodiment incorporates a maximum CSRF depth (1150) that is at least five percent of the face height, and a maximum SSRF depth (1350) that is at least five percent of the face height. An even further embodiment incorporates a maximum CSRF depth (1150) that is at least twenty percent of the face height, and a maximum SSRF depth (1350) that is at least twenty percent of the face height, again, promoting deflection and selectively controlling the peak stresses seen on the face (500) at impact. In most embodiments a maximum CSRF width (1140) and a maximum SSRF width (1340) of at least 0.0050 inches and no more than 0.750 inches is preferred.

Additional embodiments focus on the location of the crown located SRF (1100) and the sole located SRF (1300) with respect to a vertical plane defined by the shaft axis (SA) and the Xcg direction. One such embodiment has recognized improved stability and lower peak face stress when the crown located SRF (1100) and/or the sole located SRF

(1300) are located behind the shaft axis plane. Further embodiments additionally define this relationship. In one such embodiment, the CSRF leading edge (1120) is located behind the shaft axis plane a distance that is at least twenty percent of the Zcg distance. Yet another embodiment focuses on the location of the sole located SRF (1300) such that the SSRF leading edge (1320) is located behind the shaft axis plane a distance that is at least ten percent of the Zcg distance. An even further embodiment focusing on the crown located SRF (1100) incorporates a CSRF leading edge (1120) that is located behind the shaft axis plane a distance that is at least seventy-five percent of the Zcg distance. A similar embodiment directed to the sole located SRF (1300) has a SSRF leading edge (1320) that is located behind the shaft axis plane a distance that is at least seventy-five percent of the Zcg distance. Similarly, the locations of the CSRF leading edge (1120) and SSRF leading edge (1320) behind the shaft axis plane may also be related to the face height instead of the Zcg distance discussed above. For instance, in one embodiment, the CSRF leading edge (1120) is located a distance behind the shaft axis plane that is at least ten percent of the face height. A further embodiment focuses on the location of the sole located SRF (1300) such that the SSRF leading edge (1320) is located behind the shaft axis plane a distance that is at least five percent of the Zcg distance. An even further embodiment focusing on both the crown located SRF (1100) and the sole located SRF (1300) incorporates a CSRF leading edge (1120) that is located behind the shaft axis plane a distance that is at least fifty percent of the face height, and a SSRF leading edge (1320) that is located behind the shaft axis plane a distance that is at least fifty percent of the face height.

The club head (400) is not limited to a single crown located SRF (1100) and/or a single sole located SRF (1300). In fact, many embodiments incorporating multiple crown located SRFs (1100) and/or multiple sole located SRFs (1300) are illustrated in FIGS. 30, 31, and 39, showing that the multiple SRFs (1100, 1300) may be positioned beside one another in a heel-toe relationship, or may be positioned behind one another in a front-rear orientation. As such, one particular embodiment includes at least two crown located SRFs (1100) positioned on opposite sides of the engineered impact point (EIP) when viewed in a top plan view, as seen in FIG. 31, thereby further selectively increasing the COR and improving the peak stress on the face (500). Traditionally, the COR of the face (500) gets smaller as the measurement point is moved further away from the engineered impact point (EIP); and thus golfers that hit the ball toward the heel side (406) or toe side (408) of the a golf club head do not benefit from a high COR. As such, positioning of the two crown located SRFs (1100) seen in FIG. 30 facilitates additional face deflection for shots struck toward the heel side (406) or toe side (408) of the golf club head (400). Another embodiment, as seen in FIG. 31, incorporates the same principles just discussed into multiple sole located SRFs (1300).

The impact of a club head (400) and a golf ball may be simulated in many ways, both experimentally and via computer modeling. First, an experimental process will be explained because it is easy to apply to any golf club head and is free of subjective considerations. The process involves applying a force to the face (500) distributed over a 0.6 inch diameter centered about the engineered impact point (EIP). A force of 4000 lbf is representative of an approximately 100 mph impact between a club head (400) and a golf ball, and more importantly it is an easy force to

apply to the face and reliably reproduce. The club head boundary condition consists of fixing the rear portion (404) of the club head (400) during application of the force. In other words, a club head (400) can easily be secured to a fixture within a material testing machine and the force applied. Generally, the rear portion (404) experiences almost no load during an actual impact with a golf ball, particularly as the “front-to-back” dimension (FB) increases. The peak deflection of the face (500) under the force is easily measured and is very close to the peak deflection seen during an actual impact, and the peak deflection has a linear correlation to the COR. A strain gauge applied to the face (500) can measure the actual stress. This experimental process takes only minutes to perform and a variety of forces may be applied to any club head (400); further, computer modeling of a distinct load applied over a certain area of a club face (500) is much quicker to simulate than an actual dynamic impact.

A graph of displacement versus load is illustrated in FIG. 44 for a club head having no stress reducing feature (1000), a club head (400) having only a sole located SRF (1300), and a club head (400) having both a crown located SRF (1100) and a sole located SRF (1300), at the following loads of 1000 lbf, 2000 lbf, 3000 lbf, and 4000 lbf, all of which are distributed over a 0.6 inch diameter area centered on the engineered impact point (EIP). The face thickness (530) was held a constant 0.090 inches for each of the three club heads. Incorporation of a crown located SRF (1100) and a sole located SRF (1300) as described herein increases face deflection by over 11% at the 4000 lbf load level, from a value of 0.027 inches to 0.030 inches. In one particular embodiment, the increased deflection resulted in an increase in the characteristic time (CT) of the club head from 187 microseconds to 248 microseconds. A graph of peak face stress versus load is illustrated in FIG. 45 for the same three variations just discussed with respect to FIG. 44. FIG. 45 nicely illustrates that incorporation of a crown located SRF (1100) and a sole located SRF (1300) as described herein reduces the peak face stress by almost 25% at the 4000 lbf load level, from a value of 170.4 ksi to 128.1 ksi. The stress reducing feature (1000) permits the use of a very thin face (500) without compromising the integrity of the club head (400). In fact, the face thickness (530) may vary from 0.050 inches, up to 0.120 inches.

Combining the information seen in FIGS. 44 and 45, a new ratio may be developed; namely, a stress-to-deflection ratio of the peak stress on the face to the displacement at a given load, as seen in FIG. 46. In one embodiment, the stress-to-deflection ratio is less than 5000 ksi per inch of deflection, wherein the approximate impact force is applied to the face (500) over a 0.6 inch diameter, centered on the engineered impact point (EIP), and the approximate impact force is at least 1000 lbf and no more than 4000 lbf, the club head volume is less than 300 cc, and the face thickness (530) is less than 0.120 inches. In yet a further embodiment, the face thickness (530) is less than 0.100 inches and the stress-to-deflection ratio is less than 4500 ksi per inch of deflection; while an even further embodiment has a stress-to-deflection ratio that is less than 4300 ksi per inch of deflection.

In addition to the unique stress-to-deflection ratios just discussed, one embodiment of the present invention further includes a face (500) having a characteristic time of at least 220 microseconds and the head volume is less than 200 cubic centimeters. Even further, another embodiment goes even further and incorporates a face (500) having a characteristic time of at least 240 microseconds, a head volume that

is less than 170 cubic centimeters, a face height between the maximum top edge height (TEH) and the minimum lower edge (LEH) that is less than 1.50 inches, and a vertical roll radius between 7 inches and 13 inches, which further increases the difficulty in obtaining such a high characteristic time, small face height, and small volume golf club head.

Those skilled in the art know that the characteristic time, often referred to as the CT, value of a golf club head is limited by the equipment rules of the United States Golf Association (USGA). The rules state that the characteristic time of a club head shall not be greater than 239 microseconds, with a maximum test tolerance of 18 microseconds. Thus, it is common for golf clubs to be designed with the goal of a 239 microsecond CT, knowing that due to manufacturing variability that some of the heads will have a CT value higher than 239 microseconds, and some will be lower. However, it is critical that the CT value does not exceed 257 microseconds or the club will not conform to the USGA rules. The USGA publication “Procedure for Measuring the Flexibility of a Golf Clubhead,” Revision 2.0, Mar. 25, 2005, is the current standard that sets forth the procedure for measuring the characteristic time.

With reference now to FIGS. 47-49, another embodiment of the crown located SRF (1100) may include a CSRF aperture (1200) recessed from the crown (600) and extending through the outer shell. As seen in FIG. 49, the CSRF aperture (1200) is located at a CSRF aperture depth (1250) measured vertically from the top edge height (TEH) toward the center of gravity (CG), keeping in mind that the top edge height (TEH) varies across the face (500) from the heel side (406) to the toe side (408). Therefore, as illustrated in FIG. 49, to determine the CSRF aperture depth (1250) one must first take a section in the front-to-rear direction of the club head (400), which establishes the top edge height (TEH) at this particular location on the face (500) that is then used to determine the CSRF aperture depth (1250) at this particular location along the CSRF aperture (1200). For instance, as seen in FIG. 47, the section that is illustrated in FIG. 49 is taken through the center of gravity (CG) location, which is just one of an infinite number of sections that can be taken between the origin and the towardmost point on the club head (400). Just slightly to the left of the center of gravity (CG) in FIG. 47 is a line representing the face center (FC), if a section such as that of FIG. 49 were taken along the face center (FC) it would illustrate that the top edge height (TEH) is generally the greatest at this point.

At least a portion of the CSRF aperture depth (1250) is greater than zero. This means that at some point along the CSRF aperture (1200), the CSRF aperture (1200) will be located below the elevation of the top of the face (400) directly in front of the point at issue, as illustrated in FIG. 49. In one particular embodiment the CSRF aperture (1200) has a maximum CSRF aperture depth (1250) that is at least ten percent of the Ycg distance. An even further embodiment incorporates a CSRF aperture (1200) that has a maximum CSRF aperture depth (1250) that is at least fifteen percent of the Ycg distance. Incorporation of a CSRF aperture depth (1250) that is greater than zero, and in some embodiments greater than a certain percentage of the Ycg distance, preferably reduces the stress in the face (500) when impacting a golf ball while accommodating temporary flexing and deformation of the crown located SRF (1100) in a stable manner in relation to the CG location, engineered impact point (EIP), and/or outer shell, while maintaining the durability of the face (500) and the crown (600).

The CSRF aperture (1200) has a CSRF aperture width (1240) separating a CSRF leading edge (1220) from a CSRF aperture trailing edge (1230), again measured in a front-to-rear direction as seen in FIG. 49. In one embodiment the CSRF aperture (1200) has a maximum CSRF aperture width (1240) that is at least twenty-five percent of the maximum CSRF aperture depth (1250) to allow preferred flexing and deformation while maintaining durability and stability upon repeated impacts with a golf ball. An even further variation achieves these goals by maintaining a maximum CSRF aperture width (1240) that is less than maximum CSRF aperture depth (1250). In yet another embodiment the CSRF aperture (1200) also has a maximum CSRF aperture width (1240) that is at least fifty percent of a minimum face thickness (530), while optionally also being less than the maximum face thickness (530).

In furtherance of these desirable properties, the CSRF aperture (1200) has a CSRF aperture length (1210) between a CSRF aperture toe-most point (1212) and a CSRF aperture heel-most point (1216) that is at least fifty percent of the Xcg distance. In yet another embodiment the CSRF aperture length (1210) is at least as great as the heel blade length section (Abl), or even further in another embodiment in which the CSRF aperture length (1210) is also at least fifty percent of the blade length (BL).

Referring again to FIG. 49, the CSRF aperture leading edge (1220) has a CSRF aperture leading edge offset (1222). In one embodiment preferred flexing and deformation occur, while maintaining durability, when the minimum CSRF aperture leading edge offset (1222) is at least ten percent of the difference between the maximum top edge height (TEH) and the minimum lower edge height (LEH). Even further, another embodiment has found preferred characteristics when the minimum CSRF aperture leading edge offset (1222) at least twenty percent of the difference between the maximum top edge height (TEH) and the minimum lower edge height (LEH), and optionally when the maximum CSRF aperture leading edge offset (1222) less than seventy-five percent of the difference between the maximum top edge height (TEH) and the minimum lower edge height (LEH).

Again with reference now to FIGS. 47-49 but now turning our attention to the sole located SRF (1300), an embodiment of the sole located SRF (1300) may include a SSRF aperture (1400) recessed from the sole (700) and extending through the outer shell. As seen in FIG. 49, the SSRF aperture (1400) is located at a SSRF aperture depth (1450) measured vertically from the leading edge height (LEH) toward the center of gravity (CG), keeping in mind that the leading edge height (LEH) varies across the face (500) from the heel side (406) to the toe side (408). Therefore, as illustrated in FIG. 49, to determine the SSRF aperture depth (1450) one must first take a section in the front-to-rear direction of the club head (400), which establishes the leading edge height (LEH) at this particular location on the face (500) that is then used to determine the SSRF aperture depth (1450) at this particular location along the SSRF aperture (1400). For instance, as seen in FIG. 47, the section that is illustrated in FIG. 49 is taken through the center of gravity (CG) location, which is just one of an infinite number of sections that can be taken between the origin and the towardmost point on the club head (400). Just slightly to the left of the center of gravity (CG) in FIG. 47 is a line representing the face center (FC), if a section such as that of FIG. 49 were taken along the face center (FC) it would illustrate that the leading edge height (LEH) is generally the least at this point.

At least a portion of the SSRF aperture depth (1450) is greater than zero. This means that at some point along the SSRF aperture (1400), the SSRF aperture (1400) will be located above the elevation of the bottom of the face (400) directly in front of the point at issue, as illustrated in FIG. 49. In one particular embodiment the SSRF aperture (1400) has a maximum SSRF aperture depth (1450) that is at least ten percent of the Ycg distance. An even further embodiment incorporates a SSRF aperture (1400) that has a maximum SSRF aperture depth (1450) that is at least fifteen percent of the Ycg distance. Incorporation of a SSRF aperture depth (1450) that is greater than zero, and in some embodiments greater than a certain percentage of the Ycg distance, preferably reduces the stress in the face (500) when impacting a golf ball while accommodating temporary flexing and deformation of the sole located SRF (1300) in a stable manner in relation to the CG location, engineered impact point (EIP), and/or outer shell, while maintaining the durability of the face (500) and the sole (700).

The SSRF aperture (1400) has a SSRF aperture width (1420) separating a SSRF leading edge (1420) from a SSRF aperture trailing edge (1430), again measured in a front-to-rear direction as seen in FIG. 49. In one embodiment the SSRF aperture (1400) has a maximum SSRF aperture width (1440) that is at least twenty-five percent of the maximum SSRF aperture depth (1450) to allow preferred flexing and deformation while maintaining durability and stability upon repeated impacts with a golf ball. An even further variation achieves these goals by maintaining a maximum SSRF aperture width (1440) that is less than maximum SSRF aperture depth (1450). In yet another embodiment the SSRF aperture (1400) also has a maximum SSRF aperture width (1440) that is at least fifty percent of a minimum face thickness (530), while optionally also being less than the maximum face thickness (530).

In furtherance of these desirable properties, the SSRF aperture (1400) has a SSRF aperture length (1410) between a SSRF aperture toe-most point (1412) and a SSRF aperture heel-most point (1416) that is at least fifty percent of the Xcg distance. In yet another embodiment the SSRF aperture length (1410) is at least as great as the heel blade length section (Abl), or even further in another embodiment in which the SSRF aperture length (1410) is also at least fifty percent of the blade length (BL).

Referring again to FIG. 49, the SSRF aperture leading edge (1420) has a SSRF aperture leading edge offset (1422). In one embodiment preferred flexing and deformation occur, while maintaining durability, when the minimum SSRF aperture leading edge offset (1422) is at least ten percent of the difference between the maximum top edge height (TEH) and the minimum lower edge height (LEH). Even further, another embodiment has found preferred characteristics when the minimum SSRF aperture leading edge offset (1422) at least twenty percent of the difference between the maximum top edge height (TEH) and the minimum lower edge height (LEH), and optionally when the maximum SSRF aperture leading edge offset (1422) less than seventy-five percent of the difference between the maximum top edge height (TEH) and the minimum lower edge height (LEH).

As previously discussed, the SRFs (1100, 1300) may be subsequently filled with a secondary material, as seen in FIG. 51, or covered, such that the volume is not visible to a golfer, similarly, the apertures (1200, 1400) may be covered or filled so that they are not noticeable to a user, and so that material and moisture is not unintentionally introduced into the interior of the club head. In other words, one need not be

able to view the inside of the club head through the aperture (1200, 1400) in order for the aperture (1200, 1400) to exist. The apertures (1200, 1400) may be covered by a badge extending over the apertures (1200, 1400), or a portion of such cover may extend into the apertures (1200, 1400), as seen in FIG. 52. If a portion of the cover extends into the aperture (1200, 1400) then that portion should be compressible and have a compressive strength that is less than fifty percent of the compressive strength of the outer shell. A badge extending over the aperture (1200, 1400) may be attached to the outer shell on only one side of the aperture (1200, 1400), or on both sides of the aperture (1200, 1400) if the badge is not rigid or utilizes non-rigid connection methods to secure the badge to the outer shell.

The size, location, and configuration of the CSRF aperture (1200) and the SSRF aperture (1400) are selected to preferably reduce the stress in the face (500) when impacting a golf ball while accommodating temporary flexing and deformation of the crown located SRF (1100) and sole located SRF (1300) in a stable manner in relation to the CG location, and/or origin point, while maintaining the durability of the face (500), the crown (600), and the sole (700). While the generally discussed apertures (1200, 1400) of FIGS. 47-49 are illustrated in the bottom wall of the SRF's (1100, 1300), the apertures (1200, 1400) may be located at other locations in the SRF's (1100, 1300) including the front wall as seen in the CSRF aperture (1100) of FIG. 50 and both the CSRF aperture (1200) and SSRF aperture (1400) of FIG. 53, as well as the rear wall as seen in the SSRF aperture (1400) of FIG. 50.

As previously explained, the golf club head (100) has a blade length (BL) that is measured horizontally from the origin point toward the toe side of the golf club head a distance that is parallel to the face and the ground plane (GP) to the most distant point on the golf club head in this direction. In one particular embodiment, the golf club head (100) has a blade length (BL) of at least 3.1 inches, a heel blade length section (Abl) is at least 1.1 inches, and a club moment arm (CMA) of less than 1.3 inches, thereby producing a long blade length golf club having reduced face stress, and improved characteristic time qualities, while not being burdened by the deleterious effects of having a large club moment arm (CMA), as is common in oversized fairway woods. The club moment arm (CMA) has a significant impact on the ball flight of off-center hits. Importantly, a shorter club moment arm (CMA) produces less variation between shots hit at the engineered impact point (EIP) and off-center hits. Thus, a golf ball struck near the heel or toe of the present invention will have launch conditions more similar to a perfectly struck shot. Conversely, a golf ball struck near the heel or toe of an oversized fairway wood with a large club moment arm (CMA) would have significantly different launch conditions than a ball struck at the engineered impact point (EIP) of the same oversized fairway wood. Generally, larger club moment arm (CMA) golf clubs impart higher spin rates on the golf ball when perfectly struck in the engineered impact point (EIP) and produce larger spin rate variations in off-center hits. Therefore, yet another embodiment incorporate a club moment arm (CMA) that is less than 1.1 inches resulting in a golf club with more efficient launch conditions including a lower ball spin rate per degree of launch angle, thus producing a longer ball flight.

Conventional wisdom regarding increasing the Z_{cg} value to obtain club head performance has proved to not recognize that it is the club moment arm (CMA) that plays a much more significant role in golf club performance and ball

flight. Controlling the club moments arm (CMA), along with the long blade length (BL), long heel blade length section (Abl), while improving the club head's ability to distribute the stresses of impact and thereby improving the characteristic time across the face, particularly off-center impacts, yields launch conditions that vary significantly less between perfect impacts and off-center impacts than has been seen in the past. In another embodiment, the ratio of the golf club head front-to-back dimension (FB) to the blade length (BL) is less than 0.925, as seen in FIGS. 6 and 13. In this embodiment, the limiting of the front-to-back dimension (FB) of the club head (100) in relation to the blade length (BL) improves the playability of the club, yet still achieves the desired high improvements in characteristic time, face deflection at the heel and toe sides, and reduced club moment arm (CMA). The reduced front-to-back dimension (FB), and associated reduced Z_{cg} , of the present invention also significantly reduces dynamic lofting of the golf club head. Increasing the blade length (BL) of a fairway wood, while decreasing the front-to-back dimension (FB) and incorporating the previously discussed characteristics with respect to the stress reducing feature (1000), minimum heel blade length section (Abl), and maximum club moment arm (CMA), produces a golf club head that has improved playability that would not be expected by one practicing conventional design principles. In yet a further embodiment a unique ratio of the heel blade length section (Abl) to the golf club head front-to-back dimension (FB) has been identified and is at least 0.32. Yet another embodiment incorporates a ratio of the club moment arm (CMA) to the heel blade length section (Abl). In this embodiment the ratio of club moment arm (CMA) to the heel blade length section (Abl) is less than 0.9. Still a further embodiment uniquely characterizes the present fairway wood golf club head with a ratio of the heel blade length section (Abl) to the blade length (BL) that is at least 0.33. A further embodiment has recognized highly beneficial club head performance regarding launch conditions when the transfer distance (TD) is at least 10 percent greater than the club moment arm (CMA). Even further, a particularly effective range for fairway woods has been found to be when the transfer distance (TD) is 10 percent to 40 percent greater than the club moment arm (CMA). This range ensures a high face closing moment (MOI_{fc}) such that bringing club head square at impact feels natural and takes advantage of the beneficial impact characteristics associated with the short club moment arm (CMA) and CG location.

Referring now to FIG. 10, in one embodiment it was found that a particular relationship between the top edge height (TEH) and the Y_{cg} distance further promotes desirable performance and feel. In this embodiment a preferred ratio of the Y_{cg} distance to the top edge height (TEH) is less than 0.40; while still achieving a long blade length of at least 3.1 inches, including a heel blade length section (Abl) that is at least 1.1 inches, a club moment arm (CMA) of less than 1.1 inches, and a transfer distance (TD) of at least 1.2 inches, wherein the transfer distance (TD) is between 10 percent to 40 percent greater than the club moment arm (CMA). This ratio ensures that the CG is below the engineered impact point (EIP), yet still ensures that the relationship between club moment arm (CMA) and transfer distance (TD) are achieved with club head design having a stress reducing feature (1000), a long blade length (BL), and long heel blade length section (Abl). As previously mentioned, as the CG elevation decreases the club moment arm (CMA) increases by definition, thereby again requiring particular attention to maintain the club moment arm (CMA) at less than 1.1 inches while reducing the Y_{cg} distance, and a significant transfer

distance (TD) necessary to accommodate the long blade length (BL) and heel blade length section (Abl). In an even further embodiment, a ratio of the Ycg distance to the top edge height (TEH) of less than 0.375 has produced even more desirable ball flight properties. Generally the top edge height (TEH) of fairway wood golf clubs is between 1.1 inches and 2.1 inches.

In fact, most fairway wood type golf club heads fortunate to have a small Ycg distance are plagued by a short blade length (BL), a small heel blade length section (Abl), and/or long club moment arm (CMA). With reference to FIG. 3, one particular embodiment achieves improved performance with the Ycg distance less than 0.65 inches, while still achieving a long blade length of at least 3.1 inches, including a heel blade length section (Abl) that is at least 1.1 inches, a club moment arm (CMA) of less than 1.1 inches, and a transfer distance (TD) of at least 1.2 inches, wherein the transfer distance (TD) is between 10 percent to 40 percent greater than the club moment arm (CMA). As with the prior disclosure, these relationships are a delicate balance among many variables, often going against traditional club head design principles, to obtain desirable performance. Still further, another embodiment has maintained this delicate balance of relationships while even further reducing the Ycg distance to less than 0.60 inches.

As previously touched upon, in the past the pursuit of high MOI fairway woods led to oversized fairway woods attempting to move the CG as far away from the face of the club, and as low, as possible. With reference again to FIG. 8, this particularly common strategy leads to a large club moment arm (CMA), a variable that the present embodiment seeks to reduce. Further, one skilled in the art will appreciate that simply lowering the CG in FIG. 8 while keeping the Ycg distance, seen in FIGS. 2 and 6, constant actually increases the length of the club moment arm (CMA). The present invention is maintaining the club moment arm (CMA) at less than 1.1 inches to achieve the previously described performance advantages, while reducing the Ycg distance in relation to the top edge height (TEH); which effectively means that the Ycg distance is decreasing and the CG position moves toward the face, contrary to many conventional design goals.

As explained throughout, the relationships among many variables play a significant role in obtaining the desired performance and feel of a golf club. One of these important relationships is that of the club moment arm (CMA) and the transfer distance (TD). One particular embodiment has a club moment arm (CMA) of less than 1.1 inches and a transfer distance (TD) of at least 1.2 inches; however in a further particular embodiment this relationship is even further refined resulting in a fairway wood golf club having a ratio of the club moment arm (CMA) to the transfer distance (TD) that is less than 0.75, resulting in particularly desirable performance. Even further performance improvements have been found in an embodiment having the club moment arm (CMA) at less than 1.0 inch, and even more preferably, less than 0.95 inches. A somewhat related embodiment incorporates a mass distribution that yields a ratio of the Ycg distance to the Ycg distance of at least two.

A further embodiment achieves a Ycg distance of less than 0.65 inches, thereby requiring a very light weight club head shell so that as much discretionary mass as possible may be added in the sole region without exceeding normally acceptable head weights, as well as maintaining the necessary durability. In one particular embodiment this is accomplished by constructing the shell out of a material having a density of less than 5 g/cm³, such as titanium alloy, non-

metallic composite, or thermoplastic material, thereby permitting over one-third of the final club head weight to be discretionary mass located in the sole of the club head. One such nonmetallic composite may include composite material such as continuous fiber pre-preg material (including thermosetting materials or thermoplastic materials for the resin). In yet another embodiment the discretionary mass is composed of a second material having a density of at least 15 g/cm³, such as tungsten. An even further embodiment obtains a Ycg distance is less than 0.55 inches by utilizing a titanium alloy shell and at least 80 grams of tungsten discretionary mass, all the while still achieving a ratio of the Ycg distance to the top edge height (TEH) is less than 0.40, a blade length (BL) of at least 3.1 inches with a heel blade length section (Abl) that is at least 1.1 inches, a club moment arm (CMA) of less than 1.1 inches, and a transfer distance (TD) of at least 1.2 inches.

A further embodiment recognizes another unusual relationship among club head variables that produces a fairway wood type golf club exhibiting exceptional performance and feel. In this embodiment it has been discovered that a heel blade length section (Abl) that is at least twice the Ycg distance is desirable from performance, feel, and aesthetics perspectives. Even further, a preferable range has been identified by appreciating that performance, feel, and aesthetics get less desirable as the heel blade length section (Abl) exceeds 2.75 times the Ycg distance. Thus, in this one embodiment the heel blade length section (Abl) should be 2 to 2.75 times the Ycg distance.

Similarly, a desirable overall blade length (BL) has been linked to the Ycg distance. In yet another embodiment preferred performance and feel is obtained when the blade length (BL) is at least 6 times the Ycg distance. Such relationships have not been explored with conventional golf clubs because exceedingly long blade lengths (BL) would have resulted. Even further, a preferable range has been identified by appreciating that performance and feel become less desirable as the blade length (BL) exceeds 7 times the Ycg distance. Thus, in this one embodiment the blade length (BL) should be 6 to 7 times the Ycg distance.

Just as new relationships among blade length (BL) and Ycg distance, as well as the heel blade length section (Abl) and Ycg distance, have been identified; another embodiment has identified relationships between the transfer distance (TD) and the Ycg distance that produce a particularly playable golf club. One embodiment has achieved preferred performance and feel when the transfer distance (TD) is at least 2.25 times the Ycg distance. Even further, a preferable range has been identified by appreciating that performance and feel deteriorate when the transfer distance (TD) exceeds 2.75 times the Ycg distance. Thus, in yet another embodiment the transfer distance (TD) should be within the relatively narrow range of 2.25 to 2.75 times the Ycg distance for preferred performance and feel.

All the ratios used in defining embodiments of the present invention involve the discovery of unique relationships among key club head engineering variables that are inconsistent with merely striving to obtain a high MOI or low CG using conventional golf club head design wisdom. Numerous alterations, modifications, and variations of the preferred embodiments disclosed herein will be apparent to those skilled in the art and they are all anticipated and contemplated to be within the spirit and scope of the instant invention. Further, although specific embodiments have been described in detail, those with skill in the art will understand that the preceding embodiments and variations can be modified to incorporate various types of substitute

25

and or additional or alternative materials, relative arrangement of elements, and dimensional configurations. Accordingly, even though only few variations of the present invention are described herein, it is to be understood that the practice of such additional modifications and variations and the equivalents thereof, are within the spirit and scope of the invention as defined in the following claims.

We claim:

1. A hollow golf club having a stress reducing feature with aperture comprising:

(A) a shaft (200) having a proximal end (210) and a distal end (220);

(B) a grip (300) attached to the shaft proximal end (210); and

(C) a golf club head (400) attached to the shaft distal end (220) and having:

(i) a face (500) positioned at a front portion (402) of the golf club head (400) where the golf club head (400) impacts a golf ball, and wherein the face (400) includes a top edge height (TEH) and a lower edge height (LEH);

(ii) a sole (700) positioned at a bottom portion of the golf club head (400);

(iii) a crown (600) positioned at a top portion of the golf club head (400);

(iv) a skirt (800) positioned around a portion of a periphery of the golf club head (400) between the sole (700) and the crown (600), wherein the face (500), sole (700), crown (600), and skirt (800) define an outer shell that further defines a head volume, and wherein the golf club head (400) has a rear portion (404) opposite the face (500);

(v) a bore having a center that defines a shaft axis (SA) which intersects with a horizontal ground plane (GP) to define an origin point, wherein the bore is located at a heel side (406) of the golf club head (400) and receives the shaft distal end (220) for attachment to the golf club head (400), and wherein a toe side (408) of the golf club head (400) is located opposite of the heel side (406);

(vi) a center of gravity (CG) of the golf club head (400) located:

(a) vertically toward the crown (600) of the golf club head (400) from the origin point a distance Y_{cg} ;

(b) horizontally from the origin point toward the toe side (408) of the golf club head (400) a distance X_{cg} that is generally parallel to the face (500) and the ground plane (GP); and

(c) a distance Z_{cg} from the origin toward the rear portion (404) in a direction generally orthogonal to the vertical direction used to measure Y_{cg} and generally orthogonal to the horizontal direction used to measure X_{cg} ;

(vii) a stress reducing feature (1000) including a sole located SRF (1300) located at least partially on the sole (700), wherein:

(a) the sole located SRF (1300) has a SSRF length (1310) between a SSRF toe-most point (1312) and a SSRF heel-most point (1316), a SSRF leading edge (1320) having a SSRF leading edge offset (1322), a SSRF trailing edge (1330), a SSRF volume, a SSRF width (1340), and a SSRF depth (1350), wherein the sole located SRF (1300) has at least one of (a) a portion of the SSRF width (1340) is at least ten percent of the Z_{cg} distance, and (b) a portion of the SSRF depth (1350) is at least ten percent of the Y_{cg} distance; and

26

(b) the sole located SRF (1300) has a SSRF aperture (1400) recessed from the sole (700) and extending through the outer shell, wherein the SSRF aperture (1400) has a SSRF aperture length (1410) between a SSRF aperture toe-most point (1412) and a SSRF aperture heel-most point (1416), and a SSRF aperture width (1440), wherein the SSRF aperture length (1410) is at least fifty percent of the X_{cg} distance; and

(c) the golf club head (400) has a characteristic time of at least 220 microseconds.

2. The golf club of claim 1, wherein the golf club head (400) includes a blade length (BL) measured horizontally from the origin point toward the toe side (408) of the golf club head (400) to the most distant point on the golf club head in this direction, wherein the blade length (BL) includes:

(a) a heel blade length section (Abl) measured in the same direction as the blade length (BL) from the origin point to an engineered impact point (EIP);

(b) a toe blade length section (Bbl); wherein

(c) the SSRF length (1310) and the SSRF aperture length (1410) are at least as great as the heel blade length section (Abl).

3. The golf club of claim 2, wherein the SSRF length (1310) and the SSRF aperture length (1410) are at least 50% of the blade length (BL).

4. The golf club of claim 2, wherein the face (400) has a face thickness that varies from a minimum thickness of at least 0.050" to a maximum thickness that is at least 25% greater than the minimum thickness.

5. The golf club of claim 4, wherein the SSRF aperture width (1440) of the SSRF aperture (1400) is less than the maximum face thickness.

6. The golf club of claim 5, wherein the SSRF aperture width (1440) of at least a portion of the SSRF aperture (1400) is at least fifty percent of the minimum face thickness.

7. The golf club of claim 2, wherein at least a portion of the SSRF aperture (1400) is horizontally separated from the SSRF trailing edge (1330) by a separation distance that is at least ten percent of the Z_{cg} distance.

8. The golf club of claim 2, wherein the SSRF volume is at least 1% of the head volume.

9. The golf club of claim 8, wherein the SSRF volume is no more than 5% of the head volume.

10. The golf club of claim 2, wherein a portion of the outer shell has a density of less than 5 g/cm³.

11. The golf club of claim 10, wherein the portion of the outer shell has the density of less than 5 g/cm³ is a nonmetallic composite.

12. The golf club of claim 10, wherein the Y_{cg} distance is less than 0.65".

13. The golf club of claim 1, wherein the head volume is less than 300 cubic centimeters, the face (500) has a loft of at least 12 degrees and a face height between the maximum top edge height (TEH) and the minimum lower edge (LEH) is less than 1.50".

14. The golf club of claim 13, wherein a club moment arm (CMA) from the CG to an engineered impact point (EIP) is less than 1.1", and a transfer distance (TD) is least 10 percent greater than the club moment arm (CMA).

15. The golf club of claim 14, wherein the transfer distance (TD) is no more than 40 percent greater than the club moment arm (CMA).

16. The golf club of claim 1, wherein at least a portion of the SSRF aperture (1400) is located above the lower edge height (LEH).

17. The golf club of claim 16, wherein the SSRF aperture (1400) is located at a SSRF aperture depth (1450) measured vertically from the lower edge height (LEH) toward the center of gravity (CG), and the SSRF aperture depth (1450) of at least a portion of the SSRF aperture (1400) is greater than zero.

18. A hollow golf club having a stress reducing feature with aperture comprising:

- (A) a shaft (200) having a proximal end (210) and a distal end (220);
- (B) a grip (300) attached to the shaft proximal end (210); and
- (C) a golf club head (400) attached to the shaft distal end (220) and having:
 - (i) a face (500) positioned at a front portion (402) of the golf club head (400) where the golf club head (400) impacts a golf ball, and wherein the face (400) includes a top edge height (TEH) and a lower edge height (LEH), and the face (400) has a face thickness that varies from a minimum thickness of at least 0.050" to a maximum thickness;
 - (ii) a sole (700) positioned at a bottom portion of the golf club head (400);
 - (iii) a crown (600) positioned at a top portion of the golf club head (400);
 - (iv) a skirt (800) positioned around a portion of a periphery of the golf club head (400) between the sole (700) and the crown (600), wherein the face (500), sole (700), crown (600), and skirt (800) define an outer shell that further defines a head volume, and wherein the golf club head (400) has a rear portion opposite the face (500);
 - (v) a bore having a center that defines a shaft axis (SA) which intersects with a horizontal ground plane (GP) to define an origin point, wherein the bore is located at a heel side (406) of the golf club head (400) and receives the shaft distal end (220) for attachment to the golf club head (400), and wherein a toe side (408) of the golf club head (400) is located opposite of the heel side (406);
 - (vi) a center of gravity (CG) of the golf club head (400) located:
 - (a) vertically toward the crown (600) of the golf club head (400) from the origin point a distance Ycg;

- (b) horizontally from the origin point toward the toe side (408) of the golf club head (400) a distance Xcg that is generally parallel to the face (500) and the ground plane (GP); and
- (c) a distance Zcg from the origin toward the rear portion (404) in a direction generally orthogonal to the vertical direction used to measure Ycg and generally orthogonal to the horizontal direction used to measure Xcg;
- (vii) a stress reducing feature (1000) including a sole located SRF (1300) located at least partially on the sole (700), wherein:
 - (a) the sole located SRF (1300) has a SSRF length (1310) between a SSRF toe-most point (1312) and a SSRF heel-most point (1316), a SSRF leading edge (1320) having a SSRF leading edge offset (1322), a SSRF trailing edge (1330), a SSRF volume, a SSRF width (1340), and a SSRF depth (1350), wherein the sole located SRF (1300) has at least one of (a) a portion of the SSRF width (1340) is at least ten percent of the Zcg distance, and (b) a portion of the SSRF depth (1350) is at least ten percent of the Ycg distance; and
 - (b) the sole located SRF (1300) has a SSRF aperture (1400) recessed from the sole (700) and extending through the outer shell, wherein the SSRF aperture (1400) has a SSRF aperture length (1410) between a SSRF aperture toe-most point (1412) and a SSRF aperture heel-most point (1416), and a SSRF aperture width (1440) that is less than the maximum face thickness, wherein the SSRF aperture length (1410) is at least fifty percent of the Xcg distance; and
 - (c) the golf club head (400) has a characteristic time of at least 220 microseconds.

19. The golf club of claim 18, wherein at least a portion of the SSRF aperture (1400) is horizontally separated from the SSRF trailing edge (1330) by a separation distance that is at least ten percent of the Zcg distance.

20. The golf club of claim 18, wherein the head volume is less than 300 cubic centimeters, the face (500) has a loft of at least 12 degrees and a face height between the maximum top edge height (TEH) and the minimum lower edge (LEH) is less than 1.50".

* * * * *