



US011045694B2

(12) **United States Patent**
Willett et al.

(10) **Patent No.:** **US 11,045,694 B2**

(45) **Date of Patent:** ***Jun. 29, 2021**

(54) **AERODYNAMIC GOLF CLUB HEAD**

(71) Applicant: **Taylor Made Golf Company, Inc.**,
Carlsbad, CA (US)

(72) Inventors: **Kraig Alan Willett**, Fallbrook, CA
(US); **Jeffrey J. Albertsen**, Plano, TX
(US); **Michael Scott Burnett**,
McKinney, TX (US)

(73) Assignee: **TAYLOR MADE GOLF COMPANY,
INC.**, Carlsbad, CA (US)

(*) Notice: Subject to any disclaimer, the term of this
patent is extended or adjusted under 35
U.S.C. 154(b) by 0 days.

This patent is subject to a terminal dis-
claimer.

(21) Appl. No.: **16/524,854**

(22) Filed: **Jul. 29, 2019**

(65) **Prior Publication Data**

US 2019/0381373 A1 Dec. 19, 2019

Related U.S. Application Data

(63) Continuation of application No. 15/959,467, filed on
Apr. 23, 2018, now Pat. No. 10,363,463, which is a
(Continued)

(51) **Int. Cl.**

A63B 53/04 (2015.01)

F15D 1/10 (2006.01)

(52) **U.S. Cl.**

CPC **A63B 53/0466** (2013.01); **F15D 1/10**
(2013.01); **A63B 53/042** (2020.08);
(Continued)

(58) **Field of Classification Search**

CPC A63B 53/0466; A63B 2053/042; A63B
2053/0437; A63B 2053/0412; A63B
2053/0408; A63B 225/01; A63B 53/042;
A63B 53/0408; A63B 53/0412; A63B
53/0437; A63B 2225/01; F15D 1/10

See application file for complete search history.

(56) **References Cited**

U.S. PATENT DOCUMENTS

1,526,438 A 2/1925 Scott
2,083,189 A 6/1937 Crooker
(Continued)

FOREIGN PATENT DOCUMENTS

EP 0446935 9/1991
JP H06190088 7/1994

(Continued)

OTHER PUBLICATIONS

International Searching Authority (USPTO), International Search
Report and Written Opinion for International Application No.
PCT/US 09149742, dated Aug. 27, 2009, 11 pages.

(Continued)

Primary Examiner — Michael D Dennis

(74) *Attorney, Agent, or Firm* — Dawsey Co., LPA;
David J. Dawsey

(57) **ABSTRACT**

An aerodynamic golf club head with a low center of gravity
and producing reduced aerodynamic drag forces. The club
head has crown section attributes and material attributes that
impart beneficial aerodynamic properties and performance.

20 Claims, 34 Drawing Sheets

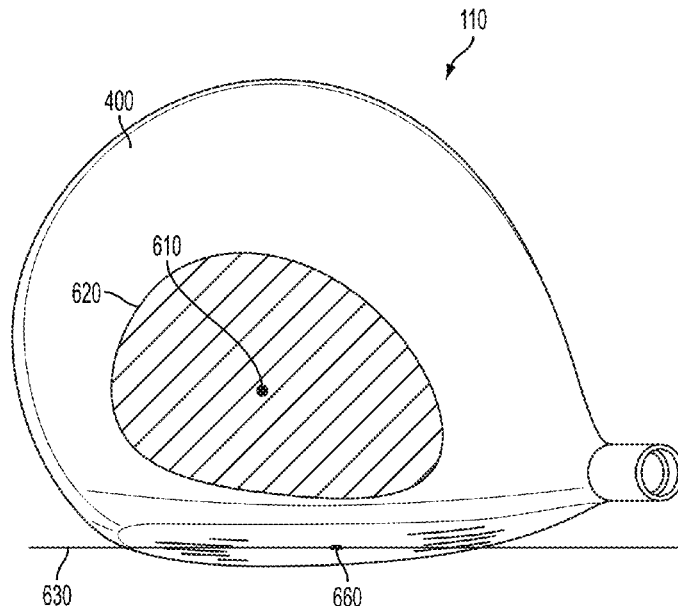

Related U.S. Application Data

continuation of application No. 15/456,630, filed on Mar. 13, 2017, now Pat. No. 9,950,224, which is a continuation of application No. 15/002,471, filed on Jan. 21, 2016, now Pat. No. 9,623,295, which is a continuation of application No. 14/488,354, filed on Sep. 17, 2014, now Pat. No. 9,259,628, which is a continuation of application No. 13/718,107, filed on Dec. 18, 2012, now Pat. No. 8,858,359, which is a continuation-in-part of application No. 13/683,299, filed on Nov. 21, 2012, now Pat. No. 8,540,586, which is a continuation of application No. 13/305,978, filed on Nov. 29, 2011, now abandoned, which is a continuation of application No. 12/409,998, filed on Mar. 24, 2009, now Pat. No. 8,088,021, which is a continuation-in-part of application No. 12/367,839, filed on Feb. 9, 2009, now Pat. No. 8,083,609.

(60) Provisional application No. 61/080,892, filed on Jul. 15, 2008, provisional application No. 61/101,919, filed on Oct. 1, 2008.

(52) **U.S. Cl.**
 CPC A63B 53/0408 (2020.08); A63B 53/0412 (2020.08); A63B 53/0437 (2020.08); A63B 2225/01 (2013.01)

(56) **References Cited**

U.S. PATENT DOCUMENTS

2,460,435	A	2/1949	Schaffer	
3,085,804	A	4/1963	Pieper	
3,166,320	A	1/1965	Onions	
3,266,805	A	8/1966	Bulla	
3,468,544	A	9/1969	Antonious	
3,637,218	A	1/1972	Carlino	
3,893,672	A	7/1975	Schonher	
3,941,390	A	3/1976	Hussey	
3,985,363	A	10/1976	Jepson et al.	
3,997,170	A	12/1976	Goldberg	
4,043,563	A	8/1977	Churchward	
4,065,133	A	12/1977	Gordos	
4,077,633	A	3/1978	Studen	
4,139,196	A	2/1979	Riley	
4,147,349	A	4/1979	Jeghers	
4,165,076	A	8/1979	Cella	
4,193,601	A	3/1980	Reid, Jr. et al.	
D256,709	S	9/1980	Reid, Jr. et al.	
4,247,105	A	1/1981	Jeghers	
D265,112	S	6/1982	Lyons	
4,431,192	A	2/1984	Stuff, Jr.	
4,432,549	A	2/1984	Zebelean	
4,471,961	A	9/1984	Masghati et al.	
4,527,799	A	7/1985	Solheim	
4,592,552	A	6/1986	Garber	
4,754,974	A	7/1988	Kobayashi	
4,787,636	A	11/1988	Honma	
4,811,950	A	3/1989	Kobayashi	
4,881,739	A	11/1989	Garcia	
4,895,367	A	1/1990	Kajita et al.	
4,919,428	A	4/1990	Perkins	
5,000,454	A	3/1991	Soda	
5,054,784	A	10/1991	Collins	
5,092,599	A	3/1992	Okumoto et al.	
5,116,054	A	5/1992	Johnson	
5,120,061	A *	6/1992	Tsuchida A63B 53/04 473/305	
5,190,289	A	3/1993	Nagai et al.	
5,193,810	A	3/1993	Antonious	
5,193,811	A	3/1993	Okumoto et al.	
5,219,408	A	6/1993	Sun	
5,221,086	A	6/1993	Antonious	

5,255,919	A	10/1993	Johnson	
5,301,944	A	4/1994	Koehler	
5,318,297	A	6/1994	Davis et al.	
D349,543	S	8/1994	MacDougall	
5,340,106	A	8/1994	Ravaris	
5,435,558	A	7/1995	Iriarte	
5,482,280	A	1/1996	Yamawaki	
5,499,814	A	3/1996	Lu	
5,501,459	A	3/1996	Endo	
5,511,786	A	4/1996	Antonious	
5,518,243	A	5/1996	Redman	
5,547,427	A	8/1996	Rigal et al.	
5,558,332	A	9/1996	Cook	
D375,130	S	10/1996	Hlinka et al.	
D378,770	S	4/1997	Hlinka et al.	
5,632,695	A	5/1997	Hlinka et al.	
5,676,606	A	10/1997	Schaeffer et al.	
5,695,412	A	12/1997	Cook	
5,700,208	A	12/1997	Nelms	
5,720,674	A	2/1998	Galy	
5,759,114	A	6/1998	Bluto et al.	
5,785,608	A	7/1998	Collins	
5,797,807	A	8/1998	Moore	
RE35,931	E	10/1998	Schroder et al.	
D401,650	S	11/1998	Burrows	
5,851,160	A	12/1998	Rugge et al.	
5,876,293	A	3/1999	Musty	
5,885,166	A	3/1999	Shiraishi	
5,890,971	A	4/1999	Shiraishi	
5,935,020	A	8/1999	Stites et al.	
5,954,595	A	9/1999	Antonious	
5,967,905	A	10/1999	Nakahara et al.	
6,001,029	A	12/1999	Kobayashi	
6,033,319	A	3/2000	Farrar	
6,074,308	A	6/2000	Domas	
6,083,115	A	7/2000	King	
6,093,113	A	7/2000	Mertens	
6,123,627	A	9/2000	Antonious	
6,139,445	A	10/2000	Werner et al.	
6,162,132	A	12/2000	Yoneyama	
6,168,537	B1	1/2001	Ezawa	
6,248,025	B1	6/2001	Murphy et al.	
6,332,848	B1	12/2001	Long et al.	
6,344,002	B1	2/2002	Kajita	
6,402,639	B1	6/2002	Iwata et al.	
6,458,042	B1	10/2002	Chen	
6,464,598	B1	10/2002	Miller	
6,471,604	B2	10/2002	Hocknell et al.	
6,491,592	B2	12/2002	Cackett et al.	
6,530,847	B1	3/2003	Antonious	
6,565,452	B2	5/2003	Helmstetter et al.	
6,575,845	B2	6/2003	Galloway et al.	
6,582,323	B2	6/2003	Soracco et al.	
6,592,466	B2	7/2003	Helmstetter et al.	
6,607,452	B2	8/2003	Helmstetter et al.	
D482,420	S	11/2003	Burrows	
6,645,086	B1	11/2003	Chen	
6,648,773	B1	11/2003	Evans	
6,663,504	B2	12/2003	Hocknell et al.	
6,669,578	B1	12/2003	Evans	
6,676,536	B1	1/2004	Jacobson	
6,723,002	B1	4/2004	Barlow	
6,739,982	B2	5/2004	Murphy et al.	
6,739,983	B2	5/2004	Helmstetter et al.	
6,758,763	B2	7/2004	Murphy et al.	
6,773,359	B1	8/2004	Lee	
6,776,723	B2	8/2004	Bliss et al.	
D501,903	S	2/2005	Tanaka	
6,855,068	B2	2/2005	Antonious	
6,860,818	B2	3/2005	Mahaffey et al.	
6,860,824	B2	3/2005	Evans	
6,875,129	B2	4/2005	Erickson et al.	
6,881,159	B2	4/2005	Galloway et al.	
6,890,267	B2	5/2005	Mahaffey et al.	
6,926,619	B2	8/2005	Helmstetter et al.	
6,929,565	B2	8/2005	Nakahara et al.	
6,939,247	B1	9/2005	Schweigert et al.	
6,955,612	B2	10/2005	Lu	
6,988,960	B2	1/2006	Mahaffey et al.	

(56)

References Cited

U.S. PATENT DOCUMENTS

6,991,558 B2	1/2006	Beach et al.	7,766,765 B2	8/2010	Oyama
D515,643 S	2/2006	Ortiz	7,771,291 B1	8/2010	Willett et al.
6,994,636 B2	2/2006	Hocknell et al.	7,785,212 B2	8/2010	Lukasiewicz, Jr. et al.
6,994,637 B2	2/2006	Murphy et al.	7,803,065 B2	9/2010	Breier et al.
7,004,849 B2	2/2006	Cameron	7,811,178 B2	10/2010	Davis
7,025,692 B2	4/2006	Erickson et al.	7,846,038 B2	12/2010	Foster et al.
7,025,695 B2	4/2006	Mitsuba	7,927,229 B2	4/2011	Jertson et al.
D522,601 S	6/2006	Schweigert	7,931,546 B2	4/2011	Bennett et al.
7,066,835 B2	6/2006	Evans et al.	7,934,998 B2	5/2011	Yokota
7,070,517 B2	7/2006	Cackett et al.	7,938,740 B2	5/2011	Breier et al.
7,086,962 B2	8/2006	Galloway et al.	7,980,964 B2	7/2011	Soracco
7,097,573 B2	8/2006	Erickson et al.	7,993,216 B2	8/2011	Lee
7,118,493 B2	10/2006	Galloway	8,007,371 B2	8/2011	Breier et al.
7,121,957 B2	10/2006	Hocknell et al.	8,012,038 B1	9/2011	Beach et al.
7,125,344 B2	10/2006	Hocknell et al.	8,012,039 B2	9/2011	Greaney et al.
7,128,661 B2	10/2006	Soracco et al.	8,038,545 B2	10/2011	Soracco
7,128,664 B2	10/2006	Onoda et al.	8,043,167 B2	10/2011	Boyd et al.
7,144,333 B2	12/2006	Murphy et al.	8,062,151 B2	11/2011	Boyd et al.
7,163,470 B2	1/2007	Galloway et al.	8,083,609 B2	12/2011	Burnett et al.
7,166,038 B2	1/2007	Williams et al.	8,088,021 B2	1/2012	Albertsen et al.
7,169,058 B1	1/2007	Fagan	8,100,781 B2	1/2012	Burnett et al.
D537,495 S	2/2007	Schweigert	8,133,135 B2	3/2012	Stites et al.
7,175,541 B2	2/2007	Lo	8,147,354 B2	4/2012	Hartwell et al.
7,189,165 B2	3/2007	Yamamoto	8,167,739 B2	5/2012	Lukasiewicz, Jr. et al.
D543,600 S	5/2007	Oldknow	8,187,115 B2	5/2012	Bennett et al.
D544,939 S	6/2007	Radcliffe et al.	8,187,119 B2	5/2012	Rae et al.
7,229,362 B2	6/2007	Tavares	8,216,087 B2	7/2012	Breier et al.
D549,792 S	8/2007	Parise	8,221,260 B2	7/2012	Stites et al.
7,252,599 B2	8/2007	Hasegawa	8,226,499 B2	7/2012	Soracco
7,258,625 B2	8/2007	Kawaguchi et al.	8,303,433 B2	11/2012	Roach et al.
7,258,630 B2	8/2007	Erickson et al.	8,337,326 B2	12/2012	Lukasiewicz, Jr. et al.
7,258,631 B2	8/2007	Galloway et al.	8,409,032 B2	4/2013	Myrhum et al.
7,273,419 B2	9/2007	Evans et al.	8,419,569 B2	4/2013	Bennett et al.
D552,198 S	10/2007	Schweigert	8,425,827 B2	4/2013	Lee
D554,720 S	11/2007	Barez et al.	8,435,134 B2	5/2013	Tang et al.
7,291,074 B2	11/2007	Kouno et al.	8,460,592 B2	6/2013	Breier et al.
7,291,075 B2	11/2007	Williams et al.	D686,679 S	7/2013	Greensmith et al.
7,294,064 B2	11/2007	Tsurumaki et al.	8,475,292 B2	7/2013	Rahrig et al.
7,306,527 B2	12/2007	Williams et al.	8,496,544 B2	7/2013	Curtis et al.
7,311,614 B2	12/2007	Kumamoto	8,506,421 B2	8/2013	Stites et al.
D564,611 S	3/2008	Llewellyn	8,523,705 B2	9/2013	Breier et al.
7,338,390 B2	3/2008	Lindsay	8,529,368 B2	9/2013	Rice et al.
7,344,452 B2	3/2008	Imamoto et al.	D692,077 S	10/2013	Greensmith et al.
7,371,191 B2	5/2008	Sugimoto	8,550,935 B2	10/2013	Stites et al.
7,377,860 B2	5/2008	Breier et al.	D696,366 S	12/2013	Milo et al.
7,390,266 B2	6/2008	Gwon	D696,367 S	12/2013	Taylor et al.
7,402,113 B2	7/2008	Mori et al.	D697,152 S	1/2014	Harbert et al.
7,413,520 B1	8/2008	Hocknell et al.	8,622,847 B2	1/2014	Beach et al.
7,416,496 B2	8/2008	Galloway et al.	8,663,029 B2	3/2014	Beach et al.
7,431,667 B2	10/2008	Vincent et al.	8,715,109 B2	5/2014	Bennett et al.
7,435,190 B2	10/2008	Sugimoto	8,747,252 B2	6/2014	Lukasiewicz, Jr. et al.
7,452,286 B2	11/2008	Lin et al.	8,784,232 B2	7/2014	Jertson et al.
7,462,109 B2	12/2008	Erickson et al.	8,834,289 B2	9/2014	de la Cruz et al.
7,470,201 B2	12/2008	Nakahara et al.	8,834,290 B2	9/2014	Bezilla et al.
7,476,161 B2	1/2009	Williams et al.	8,834,294 B1	9/2014	Seluga et al.
7,481,720 B2	1/2009	Tavares	8,894,508 B2	11/2014	Myrhum et al.
D589,103 S	3/2009	Kohno	8,938,871 B2	1/2015	Roach et al.
7,497,789 B2	3/2009	Burnett et al.	8,986,133 B2	3/2015	Bennett et al.
7,503,854 B2	3/2009	Galloway et al.	9,044,653 B2	6/2015	Wahl et al.
7,524,249 B2	4/2009	Breier et al.	9,205,311 B2	12/2015	Stokke
7,549,935 B2	6/2009	Foster et al.	9,308,423 B1	4/2016	Tang et al.
7,607,991 B2	10/2009	Sorenson	9,320,949 B2	4/2016	Golden et al.
7,628,713 B2	12/2009	Tavares	9,393,471 B2	7/2016	Beno et al.
7,632,193 B2	12/2009	Thielen	9,421,438 B2	8/2016	Beno et al.
7,637,822 B2	12/2009	Foster et al.	9,440,123 B2	9/2016	Beno et al.
7,658,686 B2	2/2010	Soracco	9,457,245 B2	10/2016	Lee
7,674,187 B2	3/2010	Cackett et al.	9,474,946 B2	10/2016	Bennett et al.
7,674,189 B2	3/2010	Beach et al.	9,498,688 B2	11/2016	Galvan et al.
7,674,190 B2	3/2010	Galloway et al.	9,504,889 B2	11/2016	Mitzel et al.
7,691,008 B2	4/2010	Oyama	9,616,301 B2	4/2017	Clausen et al.
7,731,603 B2	6/2010	Beach et al.	9,636,559 B2	5/2017	de la Cruz et al.
7,749,097 B2	7/2010	Foster et al.	9,682,299 B2	6/2017	Tang et al.
7,758,454 B2	7/2010	Burnett et al.	9,821,198 B2	11/2017	Stokke
D622,338 S	8/2010	Kohno	9,855,474 B2	1/2018	Beno et al.
D622,795 S	8/2010	Furutate	9,901,794 B2	2/2018	Beno et al.
			9,908,013 B2	3/2018	Hettinger et al.
			10,004,958 B2	6/2018	Tang et al.
			10,076,689 B2	9/2018	de la Cruz et al.
			10,076,694 B2	9/2018	Galvan et al.

(56)

References Cited

FOREIGN PATENT DOCUMENTS

JP	5264899	8/2013
JP	5280914	9/2013
JP	5280975	9/2013
JP	5324992	10/2013
JP	5341993	11/2013
JP	5342393	11/2013
JP	5349006	11/2013
JP	5359782	12/2013
JP	5374108	12/2013
JP	5377299	12/2013
JP	5952655	1/2014
JP	5152431	2/2014
JP	5421147	2/2014
JP	5427598	2/2014
JP	5451187	3/2014
JP	5601726	10/2014
JP	5637864	12/2014
JP	5671507	2/2015
JP	5690766	3/2015
JP	5785893	9/2015
JP	5785895	9/2015
JP	5795919	10/2015
JP	5823121	11/2015
JP	5823122	11/2015
JP	5886595	3/2016
JP	5886652	3/2016
JP	5996573	9/2016
JP	6002713	10/2016
JP	6011044	10/2016
JP	6074924	2/2017
JP	6082366	2/2017
JP	6476226	2/2019
WO	2005009543	2/2005

OTHER PUBLICATIONS

Excerpts from Golf Digest; magazine; Feb. 2004; Article entitled: "The Hot List", cover page from magazine and article on pp. 82-88.

Excerpts from Golf Digest; magazine; Feb. 2005; Article entitled: "The Hot List", cover page from magazine and article on pp. 119-130. (Part 1).

Excerpts from Golf Digest; magazine; Feb. 2005; Article entitled: "The Hot List", article on pp. 131-143. (Part 2).

Excerpts from Golf Digest; magazine; Feb. 2006; Article entitled: "The Hot List", cover page from magazine and article on pp. 122-132. (Part 1).

Excerpts from Golf Digest; magazine; Feb. 2006; Article entitled: "The Hot List", article on pp. 133-143. (Part 2).

Excerpts from Golf Digest; magazine; Feb. 2007; Article entitled: "The Hot List", cover page from magazine and article on pp. 130-151.

Excerpts from Golf Digest; magazine; Feb. 2008; Article entitled: "The Hot List", cover page from magazine and article on pp. 114-139.

Excerpts from Golf Digest; magazine; Feb. 2009; Article entitled: "The Hot List", cover page from magazine and article on pp. 101-127.

International Searching Authority (USPTO), International Search Report and Written Opinion for International Application No. PCT/US2009/049418, dated Aug. 26, 2009, 10 pages.

Declaration.

"Cleveland HiBore Driver Review," <http://thesandtrip.com>, 7 pages, May 19, 2006.

"Invalidity Search Report for Japanese Registered Patent No. 4128970," 4pg. (dated Nov. 29, 2013.).

* cited by examiner

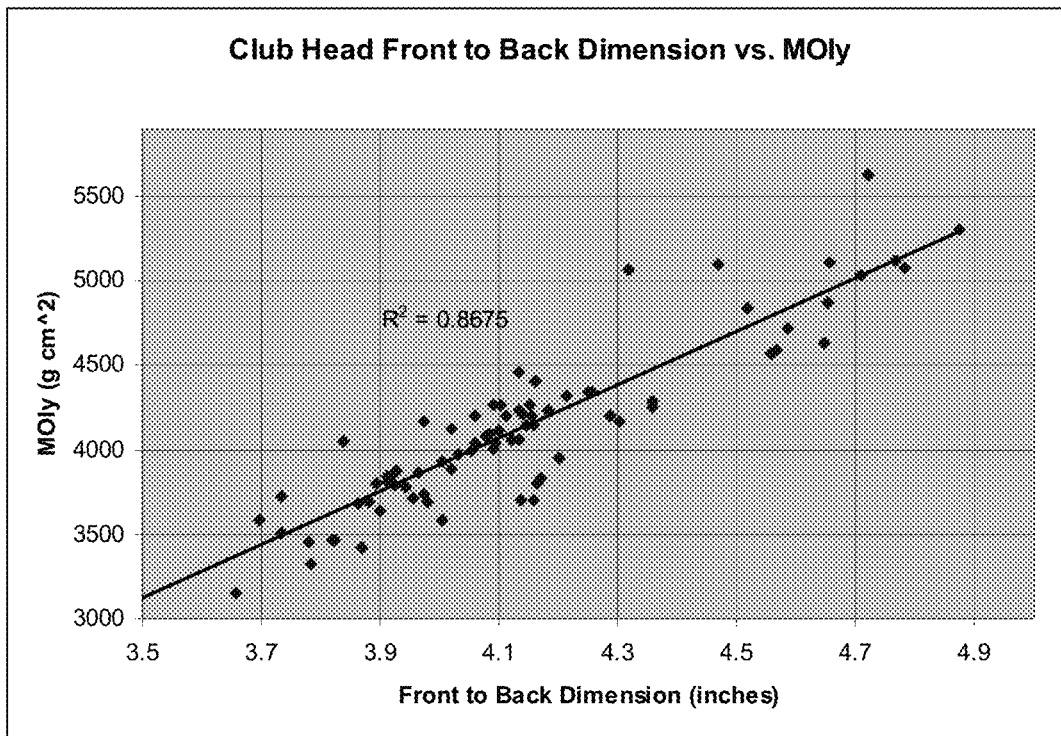

Fig. 1

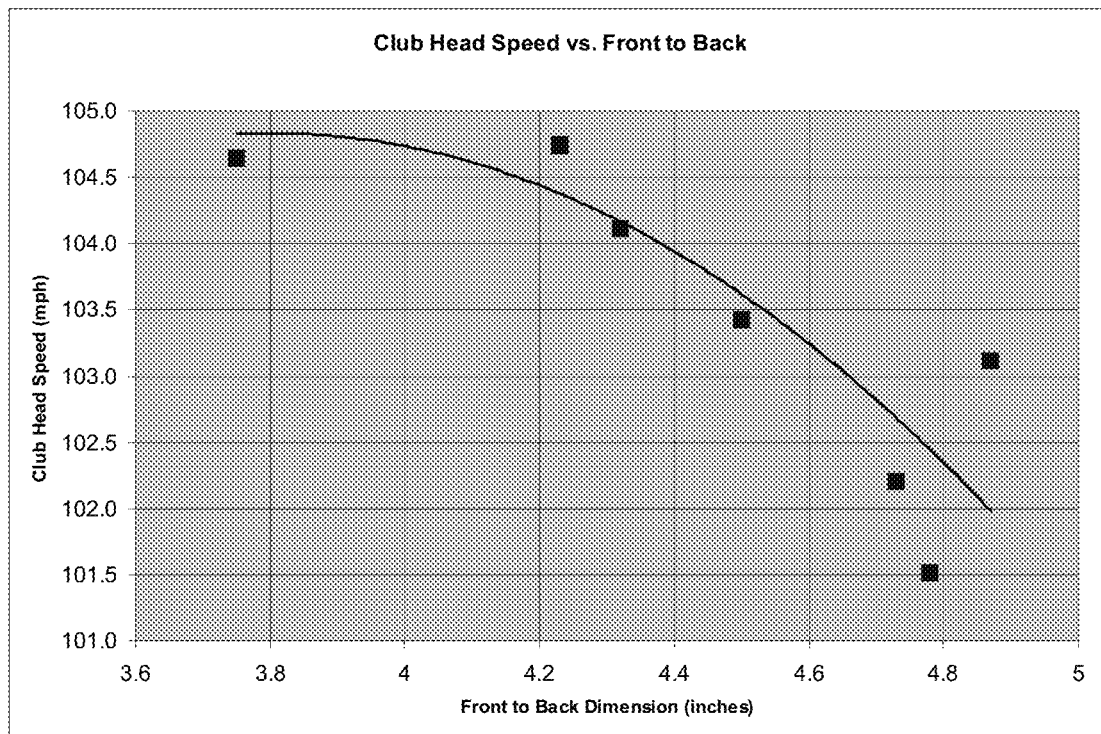

Fig. 2

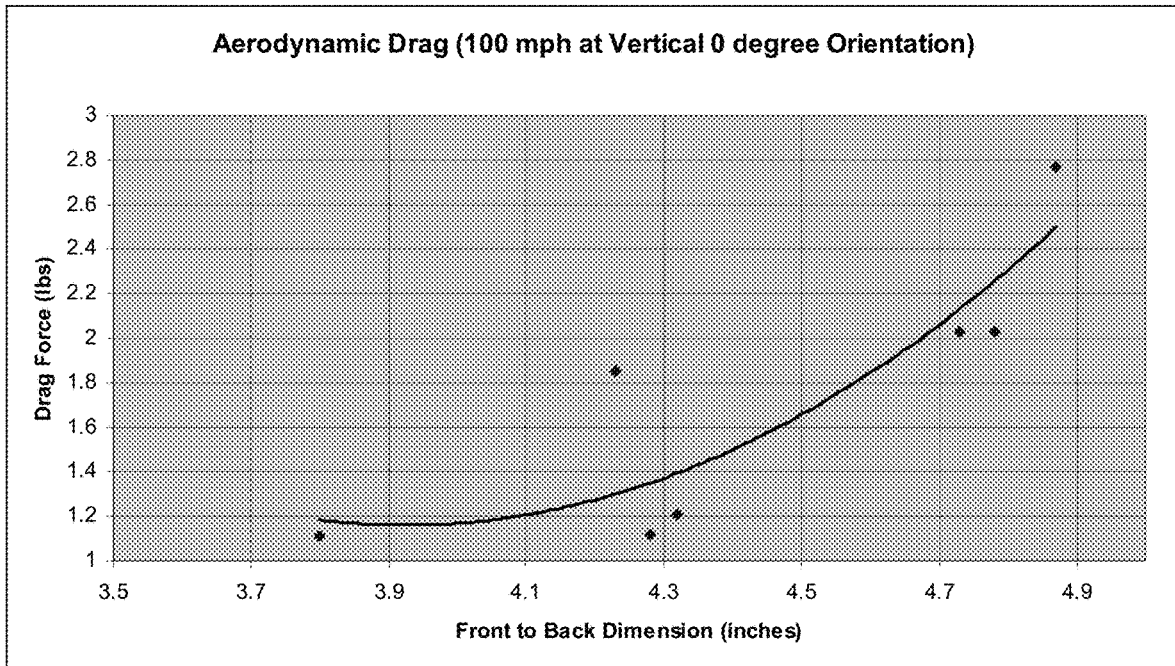

Fig. 3

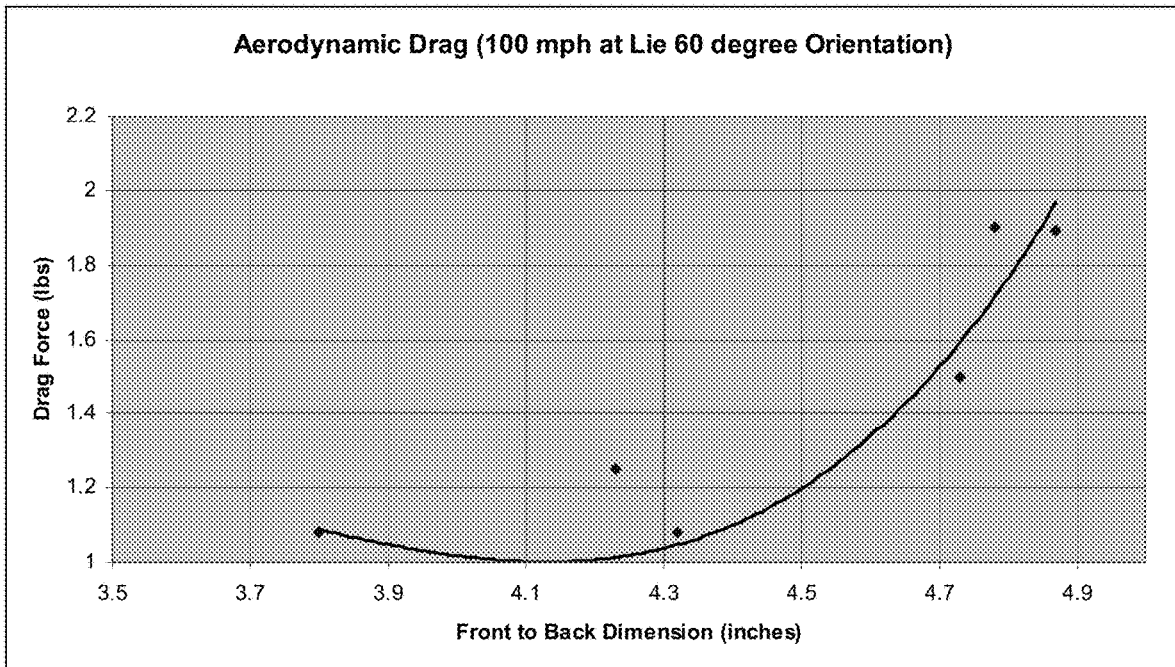

Fig. 4

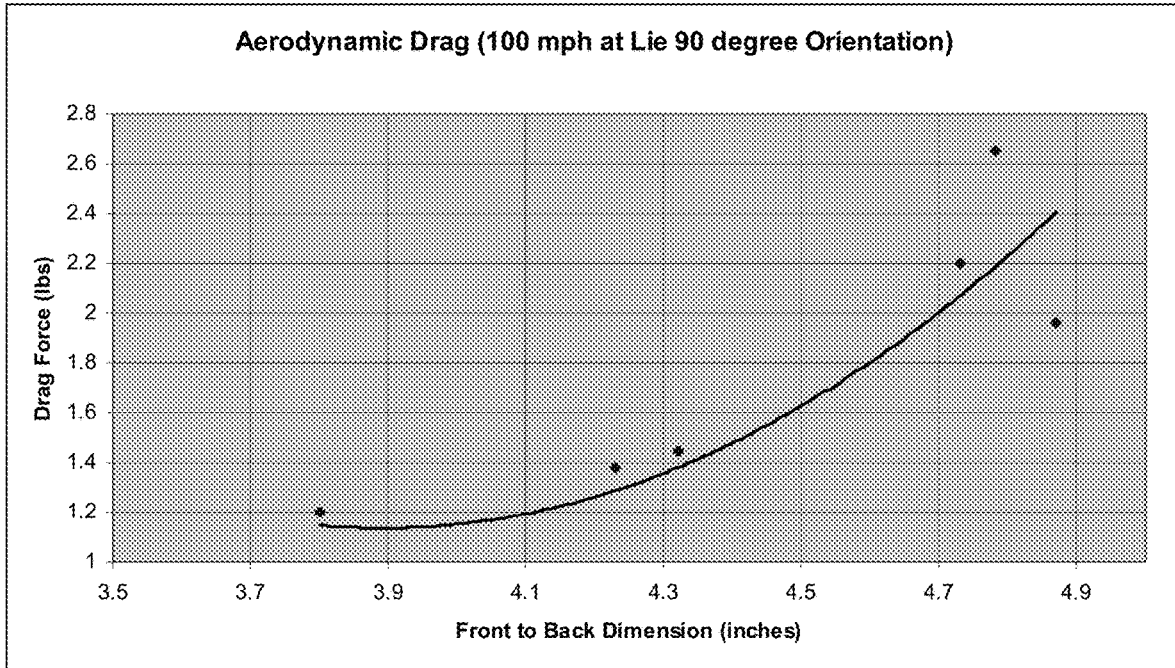

Fig. 5

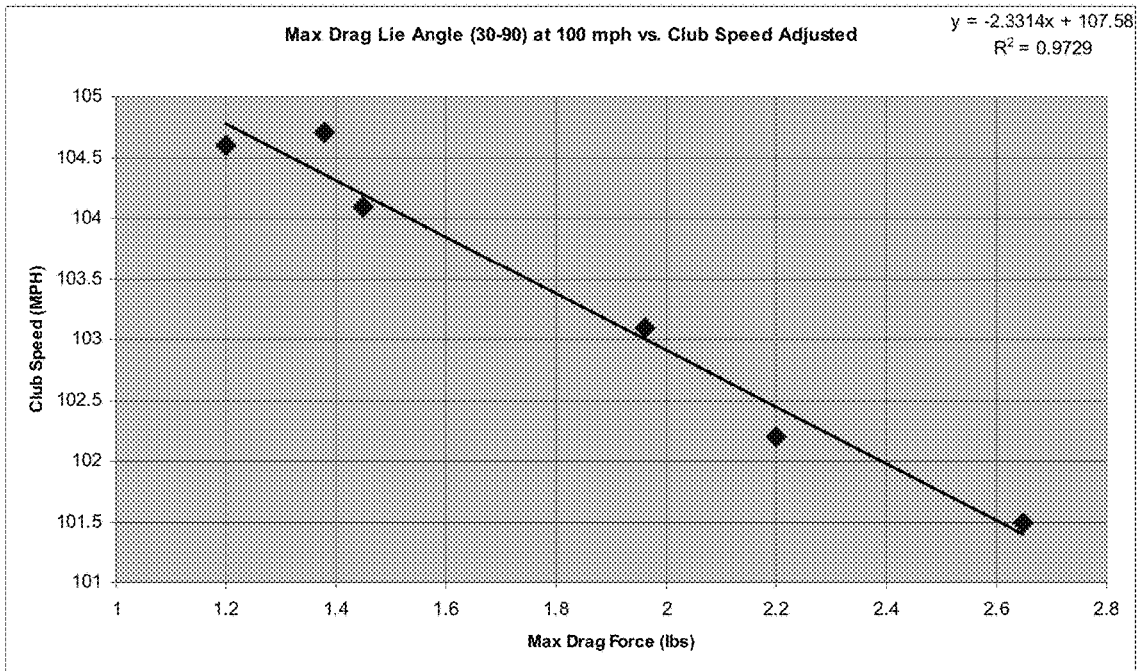

Fig. 6

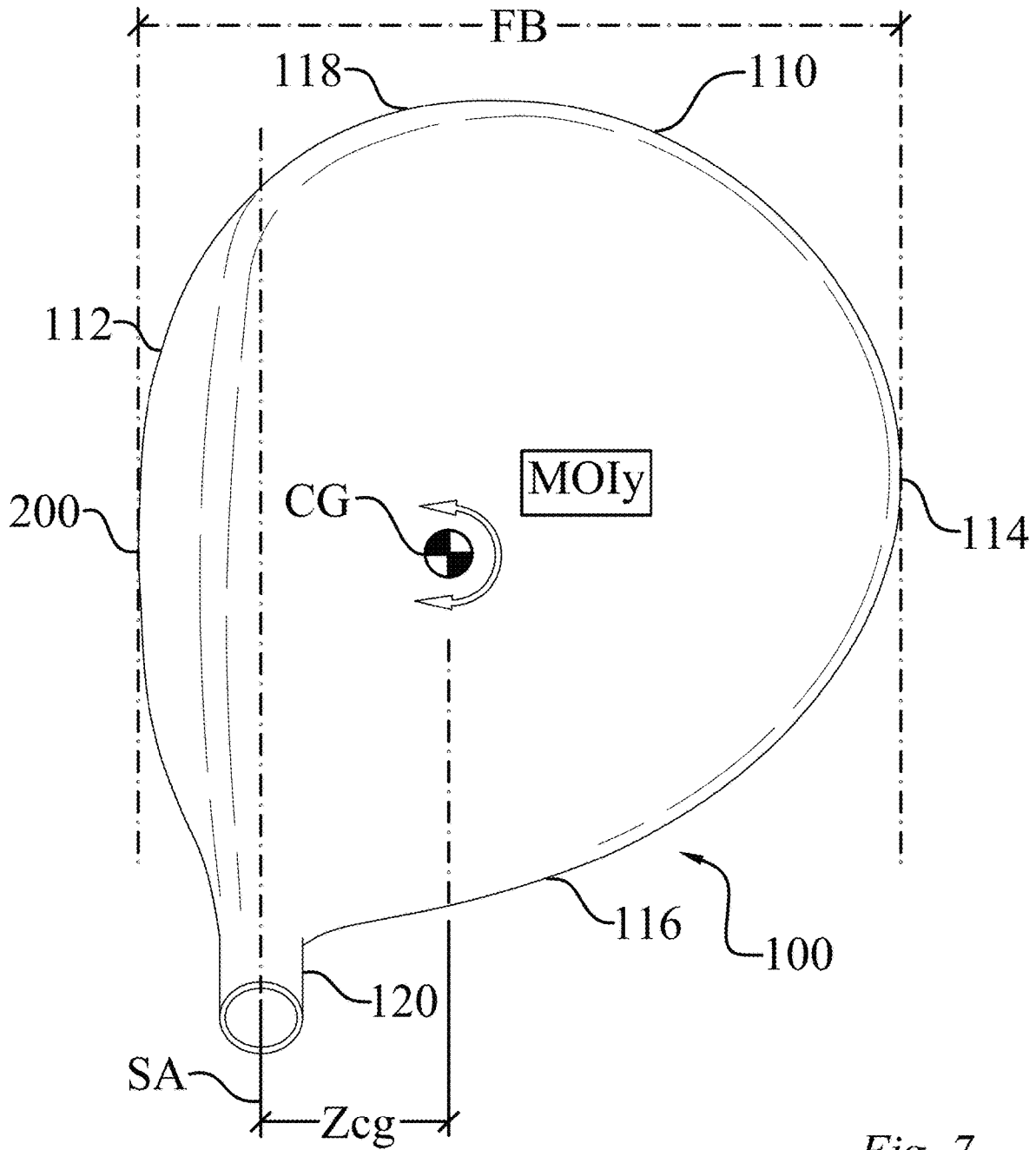

Fig. 7

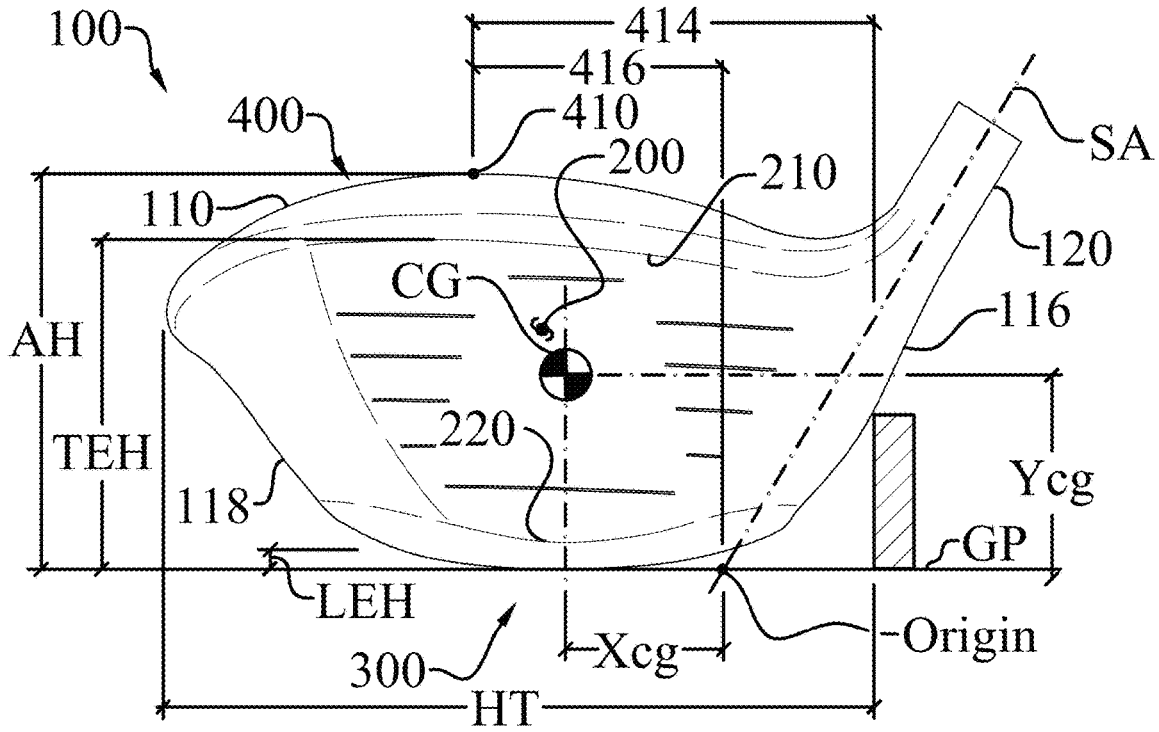

Fig. 8

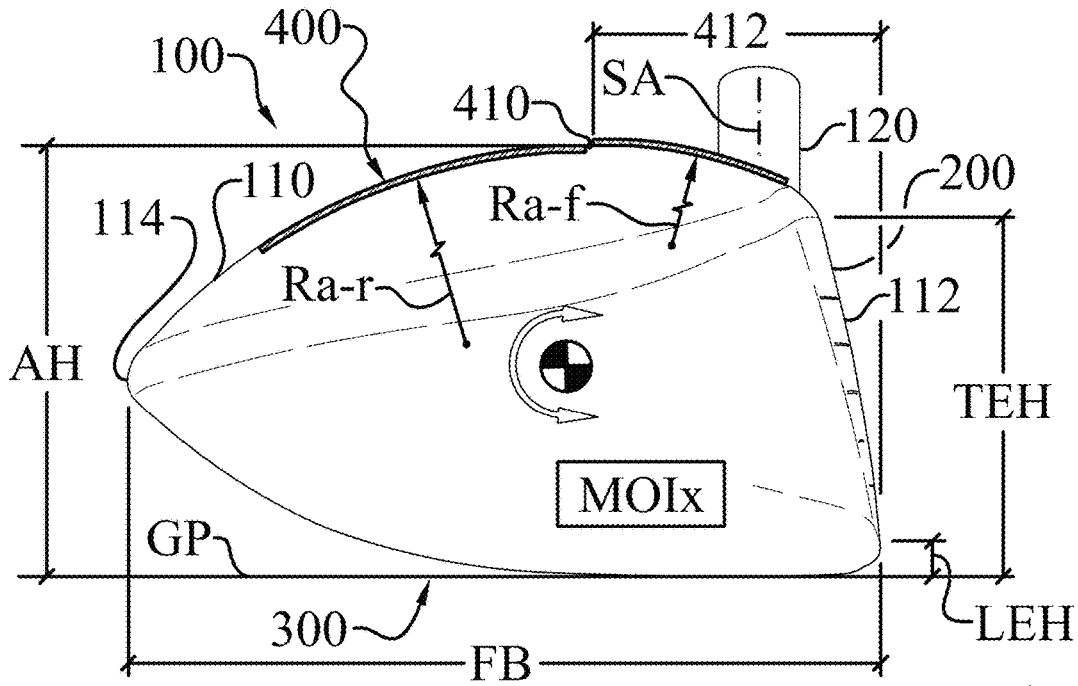

Fig. 9

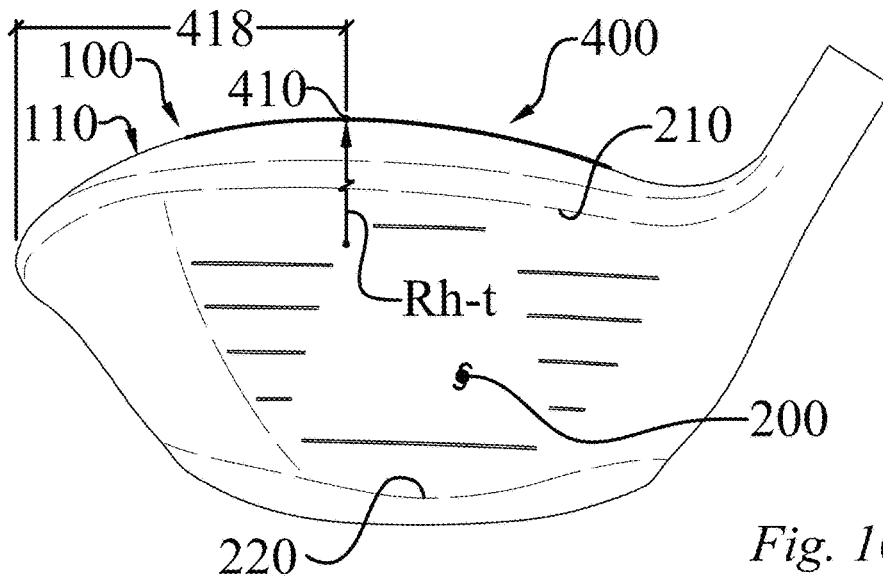

Fig. 10

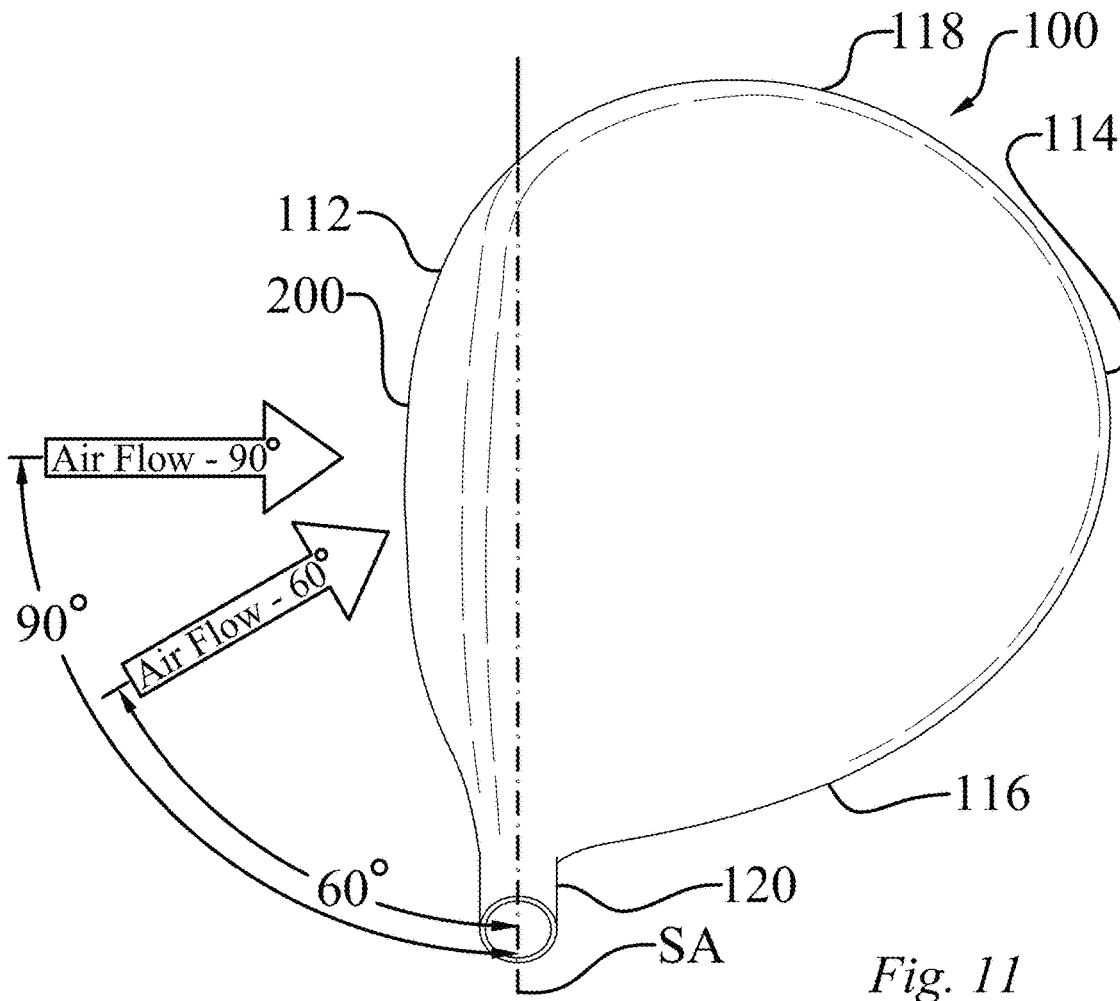

Fig. 11

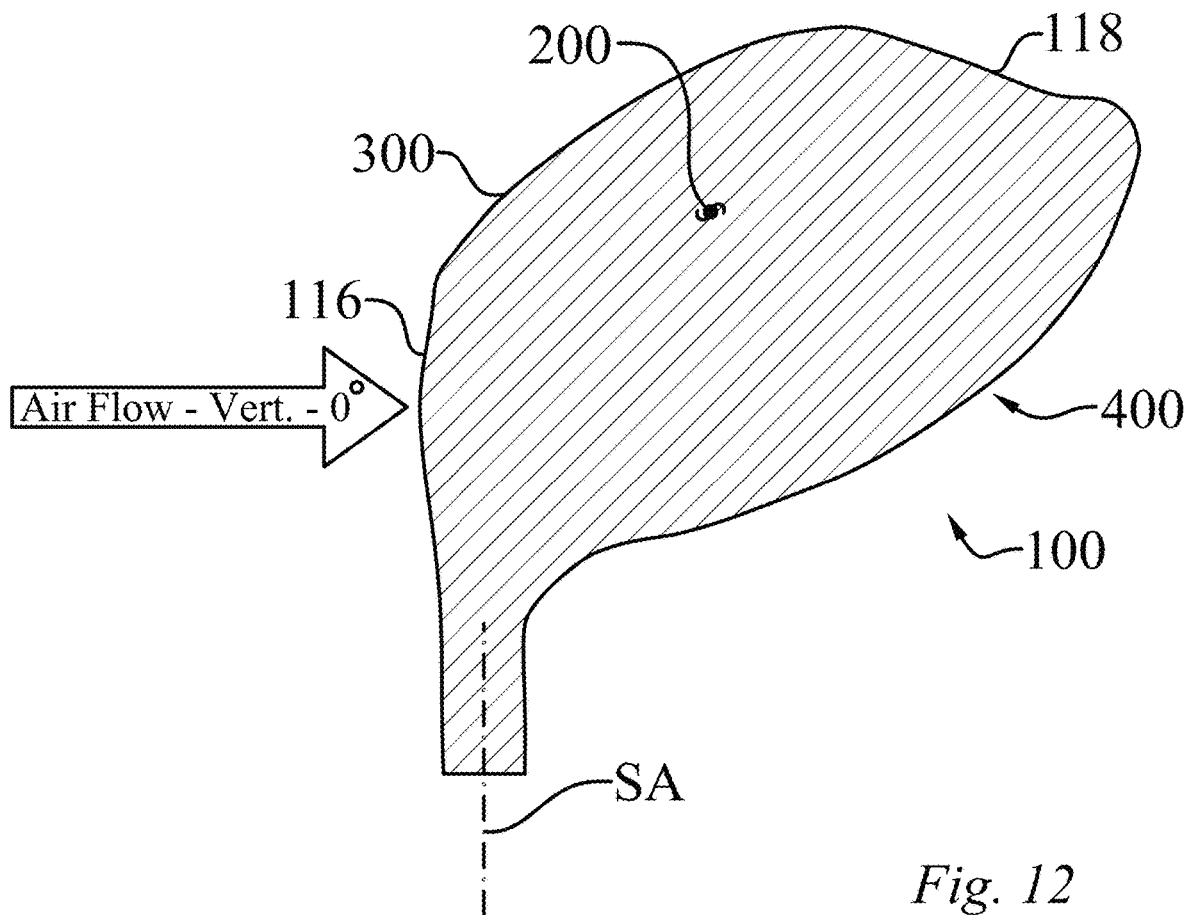

Fig. 12

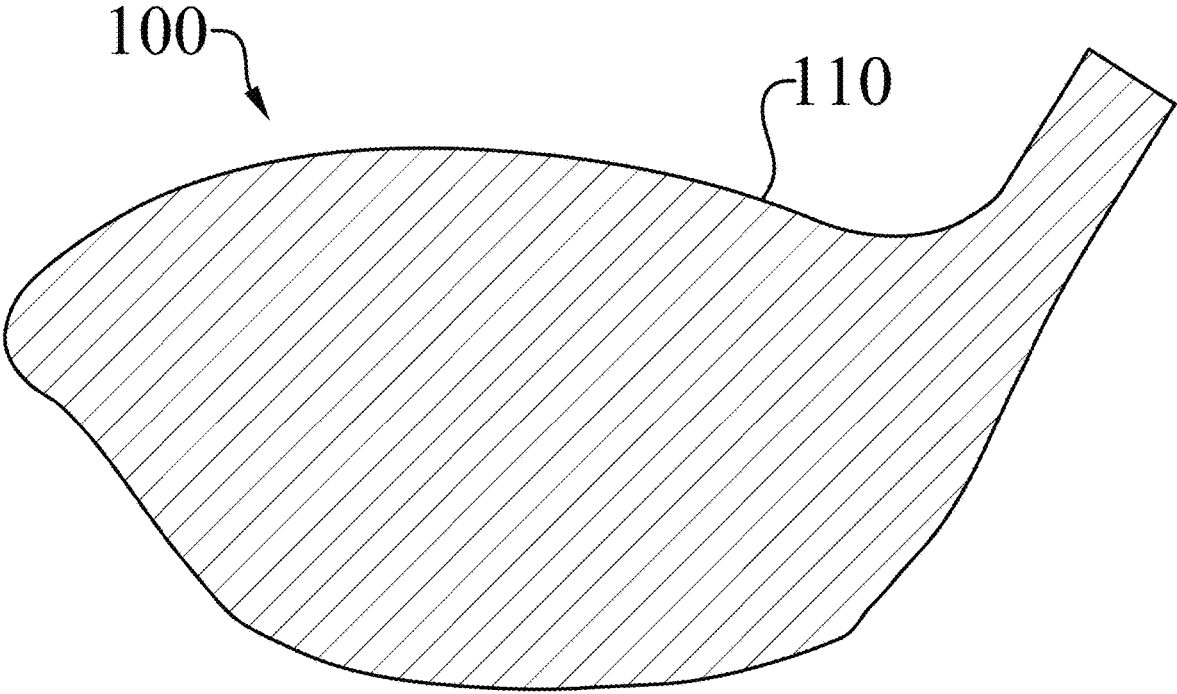

Fig. 13

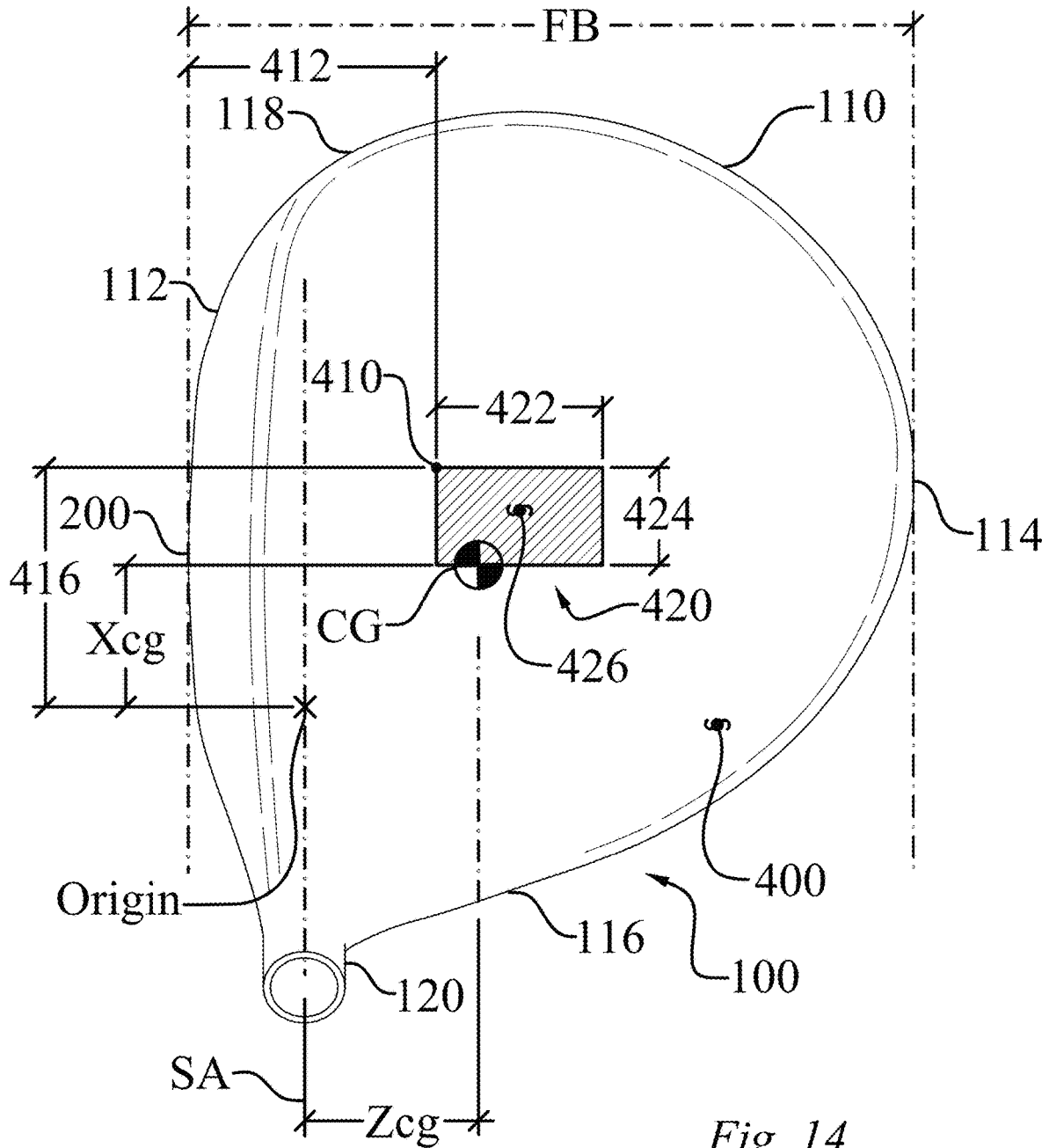

Fig. 14

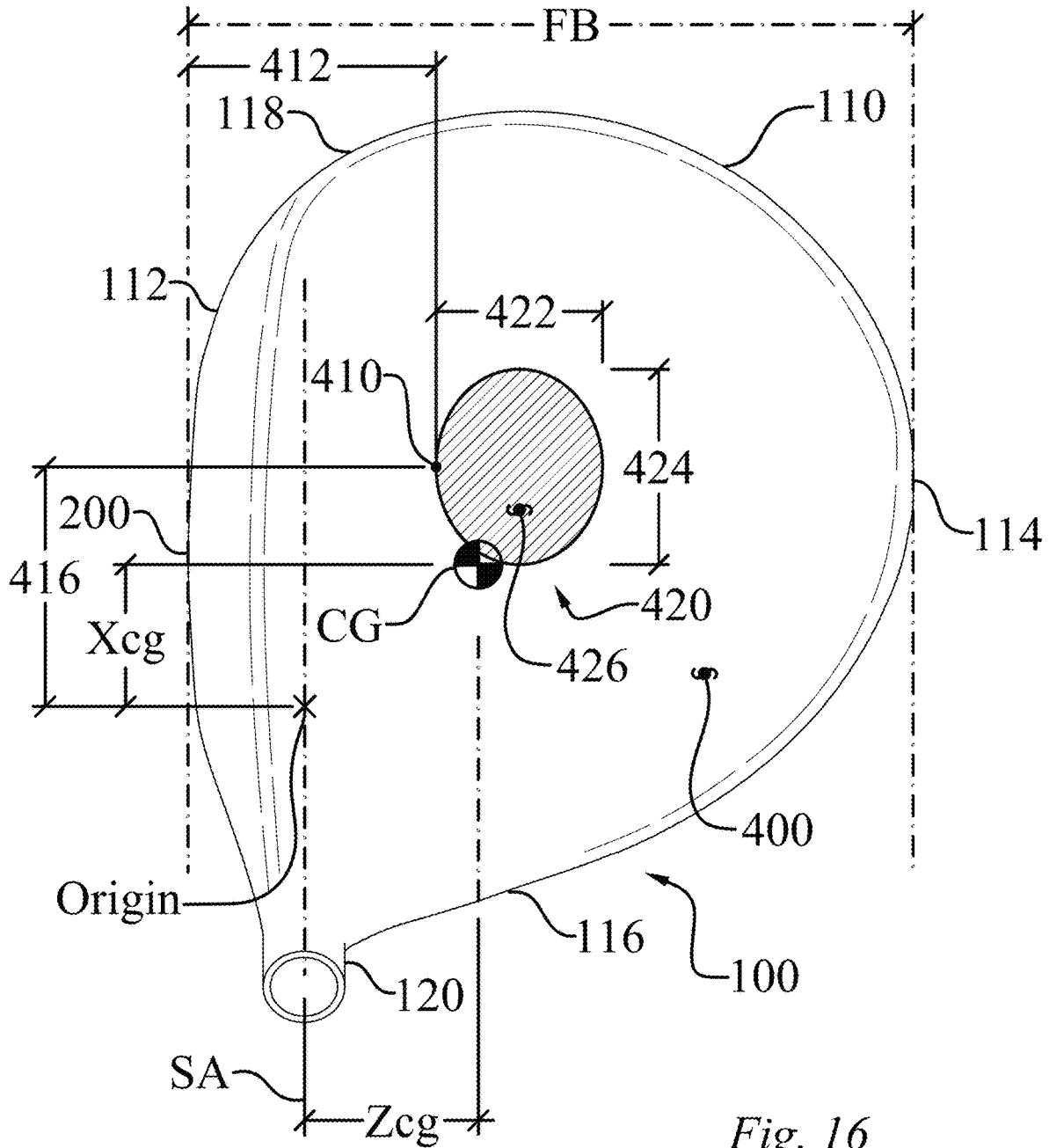

Fig. 16

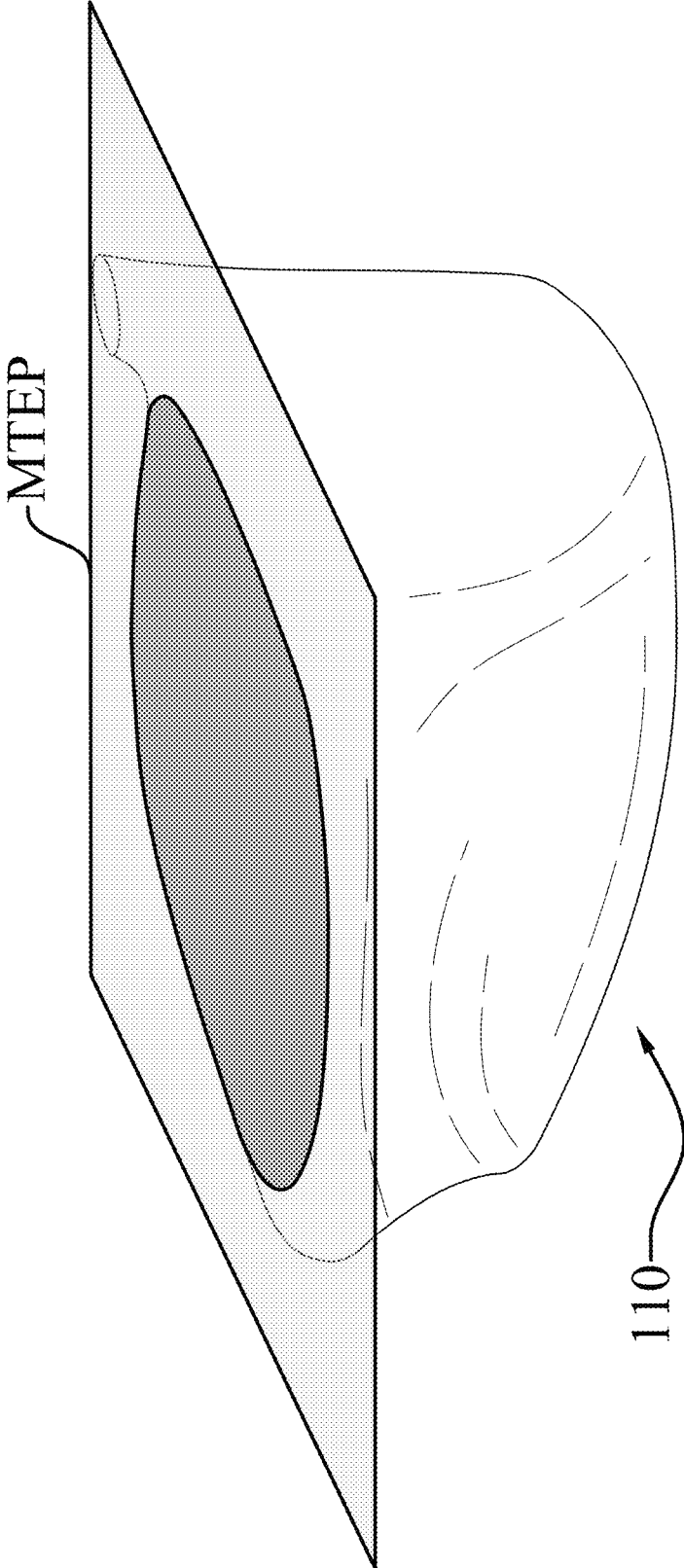

Fig. 18

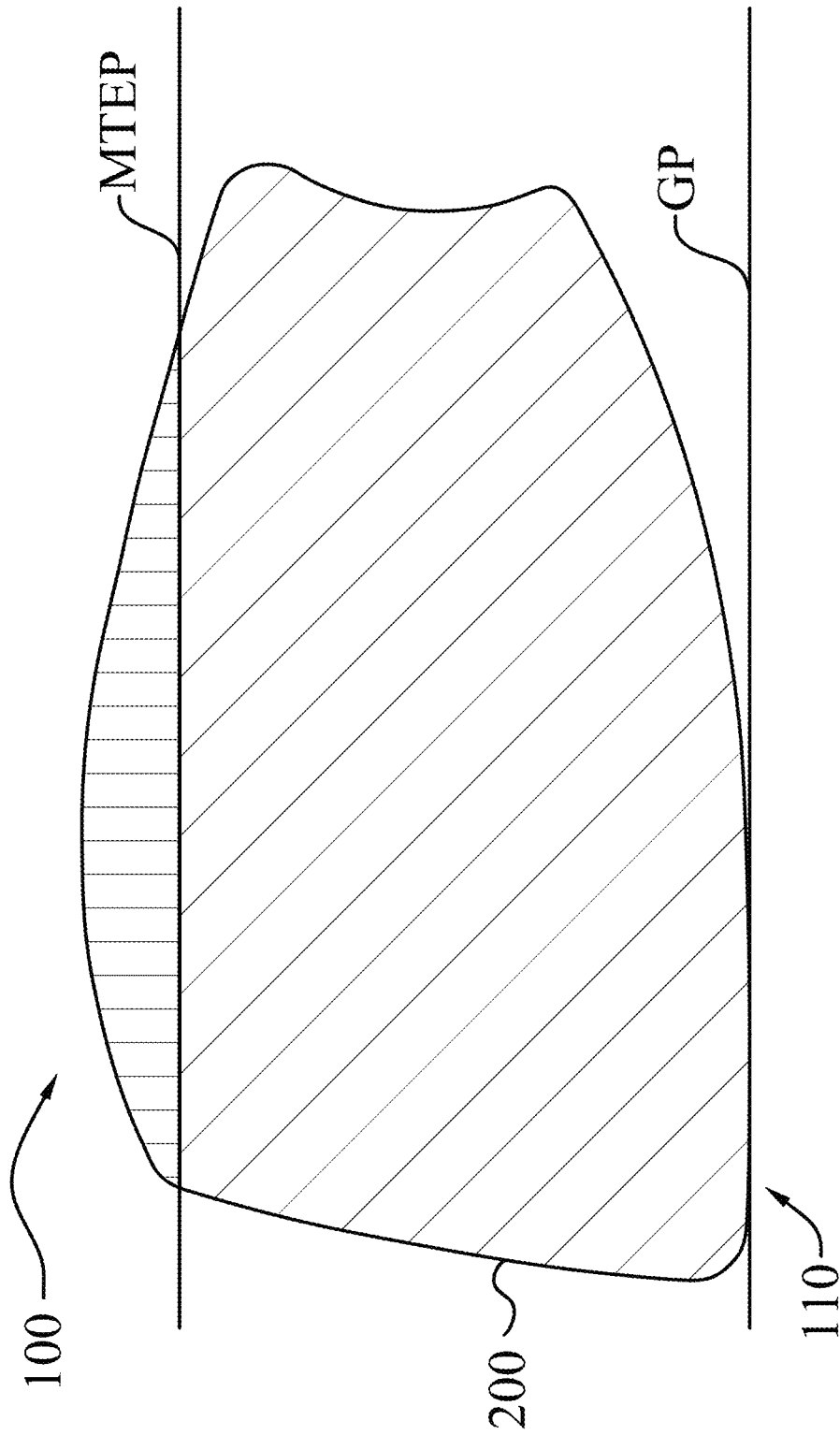

Fig. 19

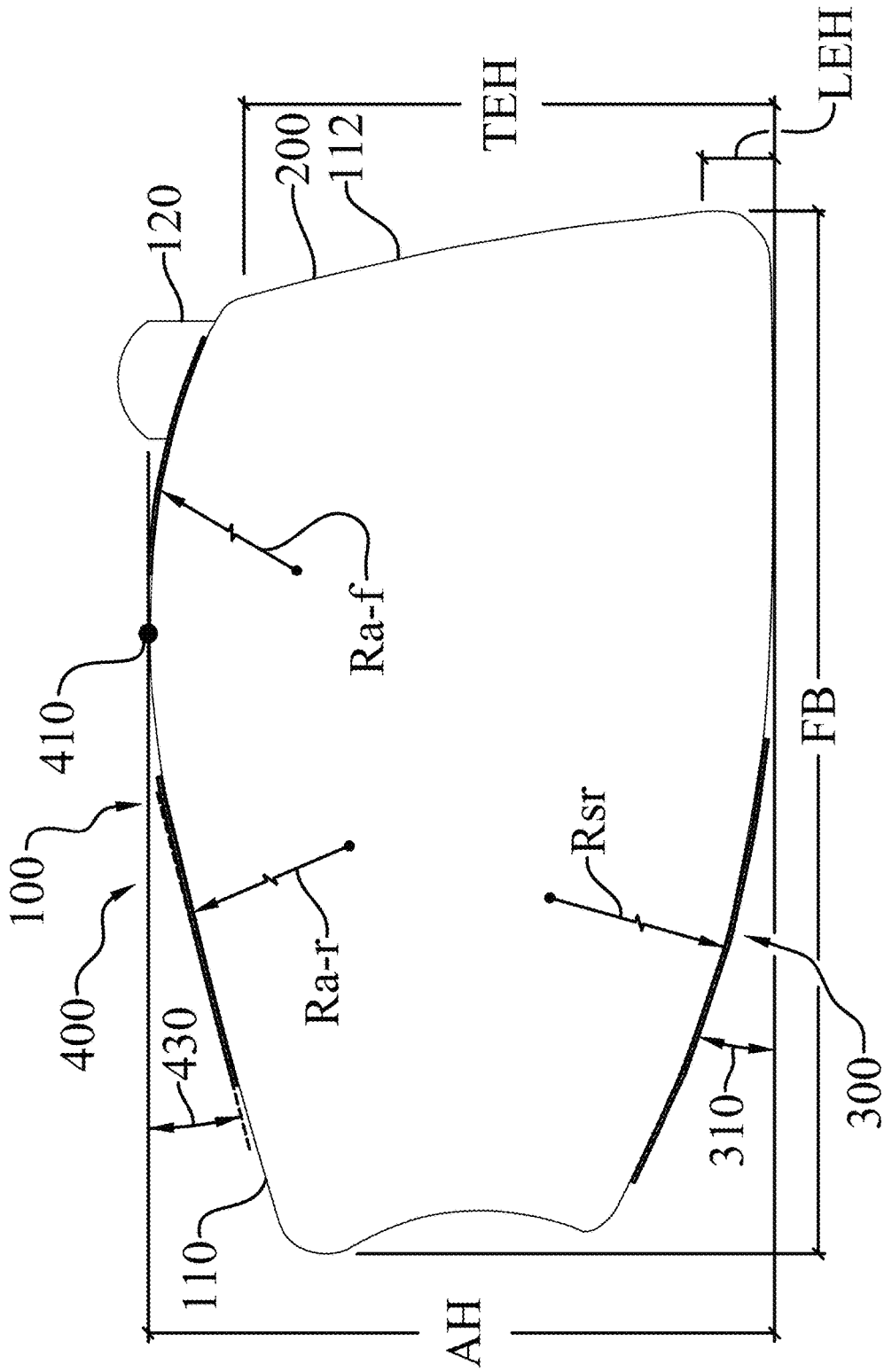

Fig. 20

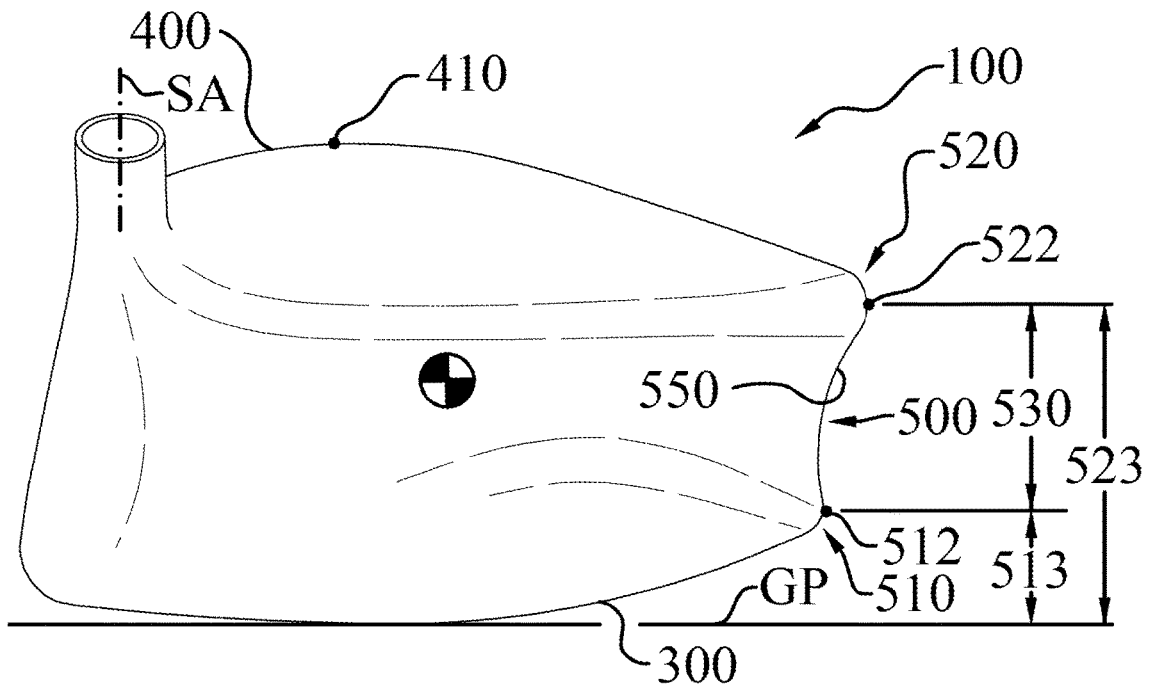

Fig. 21

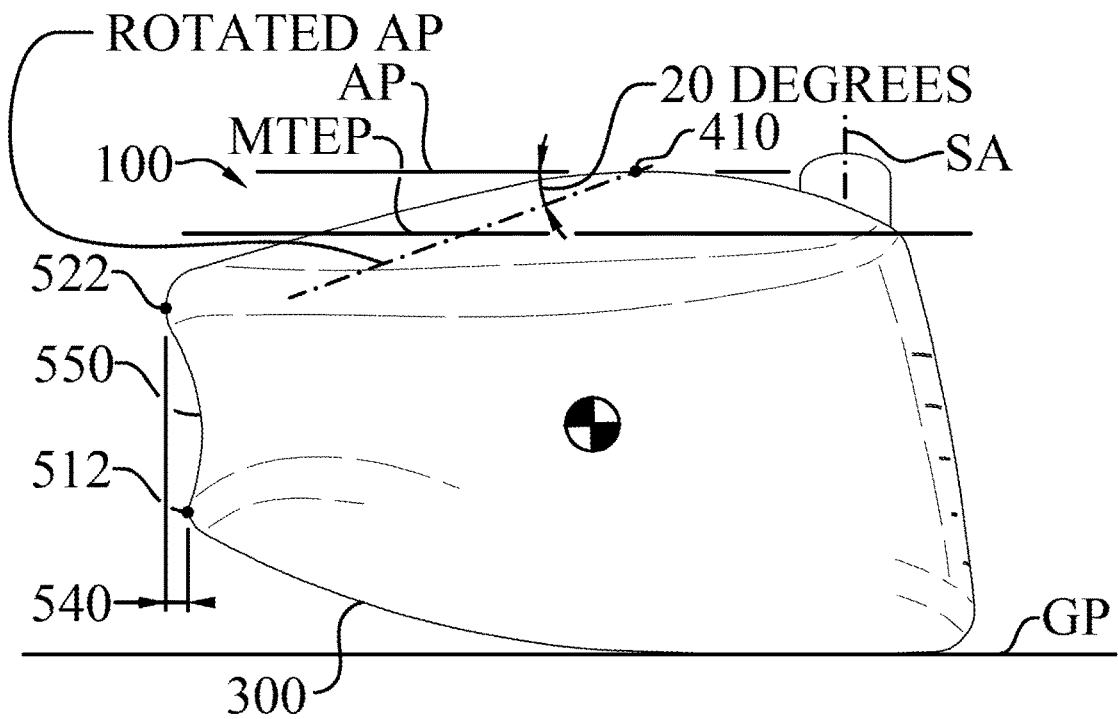

Fig. 22

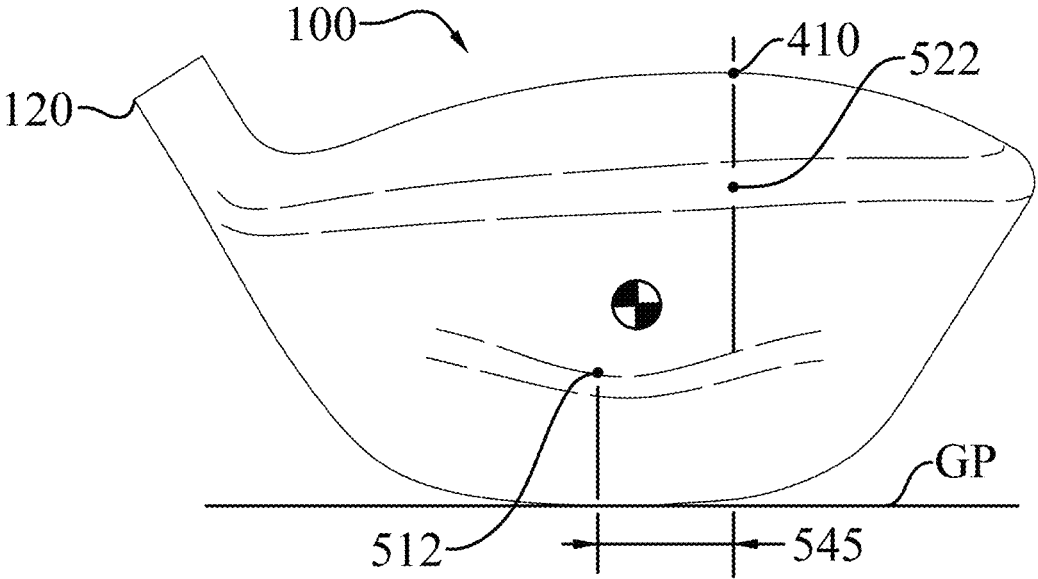

Fig. 23

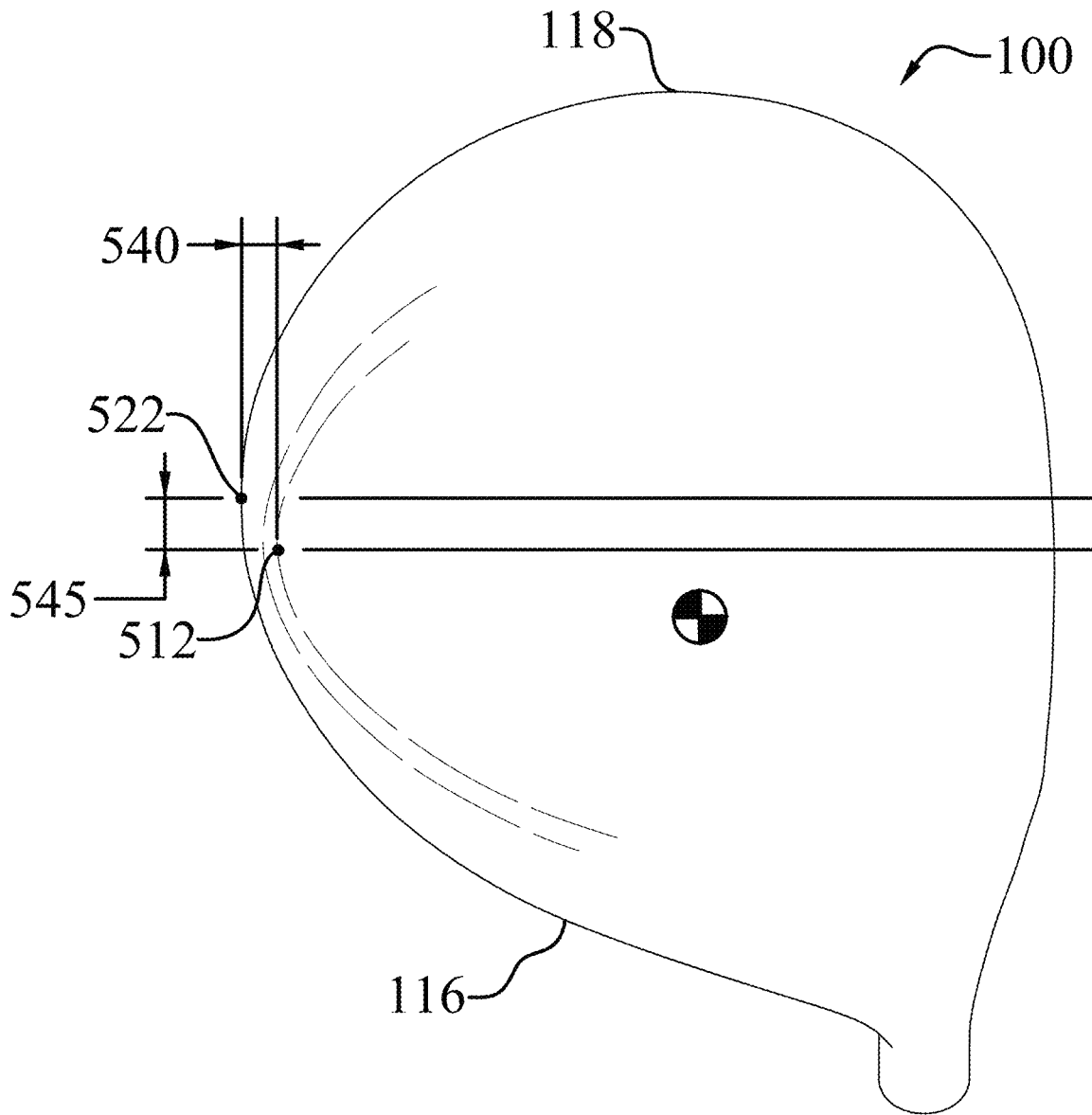

Fig. 24

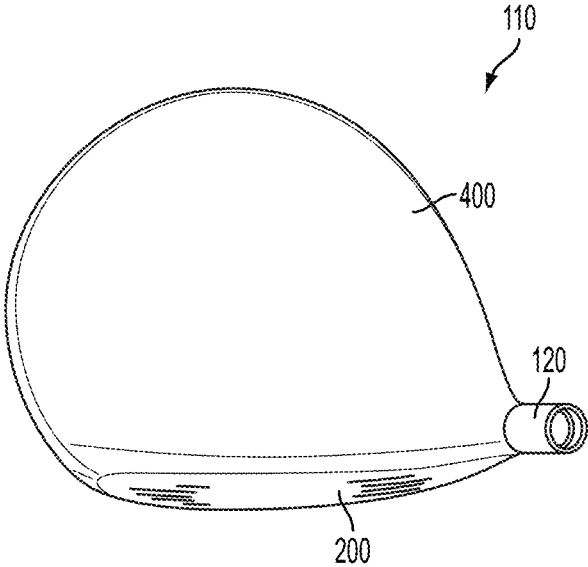

FIG. 26A

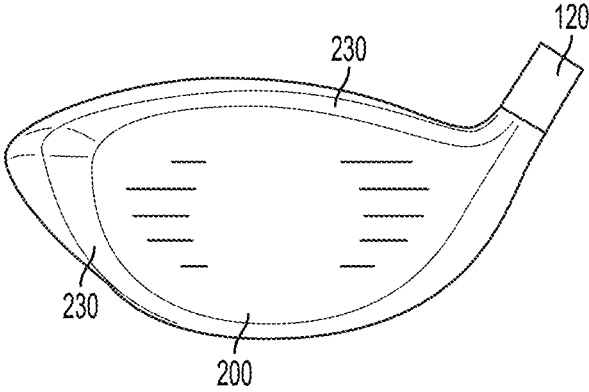

FIG. 26B

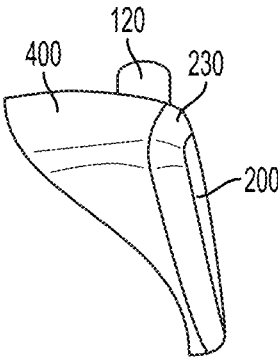

FIG. 26C

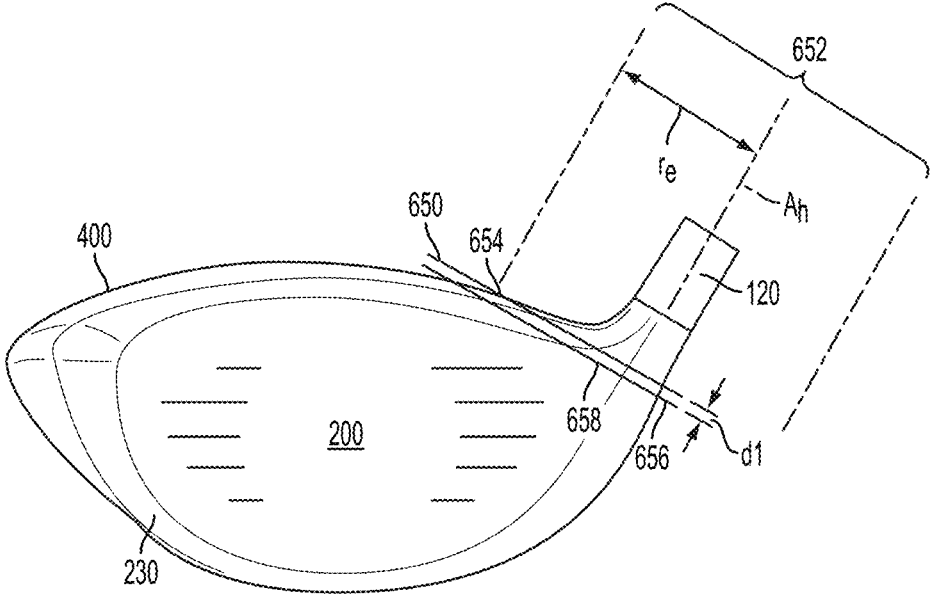

FIG. 27

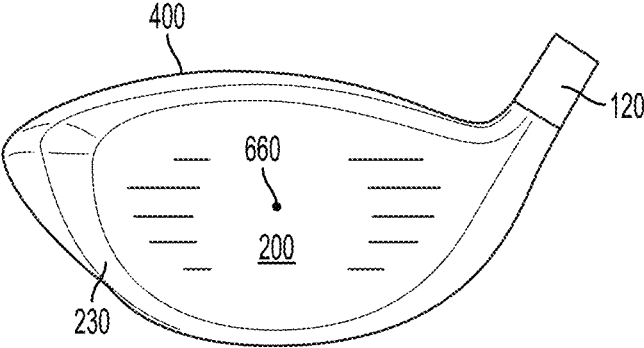

FIG. 28

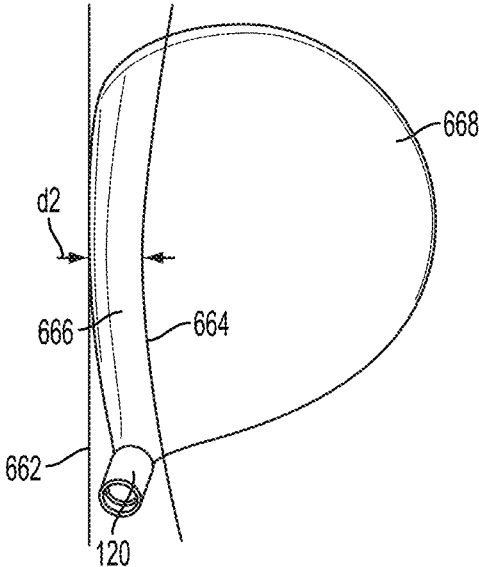

FIG. 29

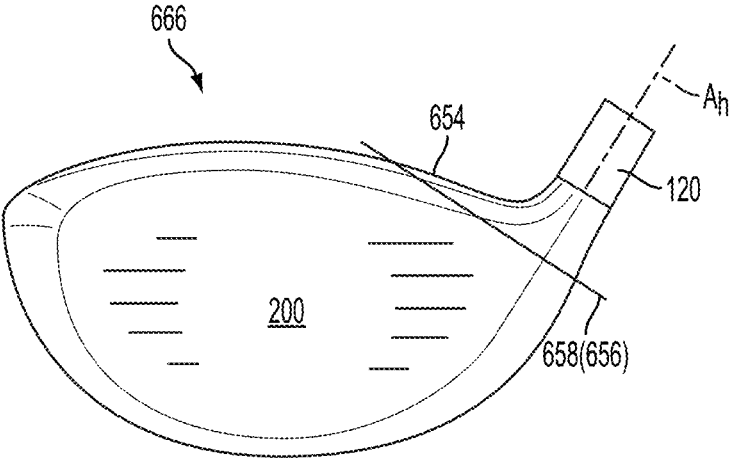

FIG. 30A

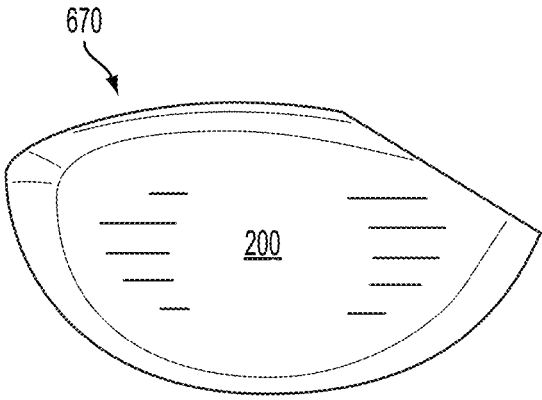

FIG. 30B

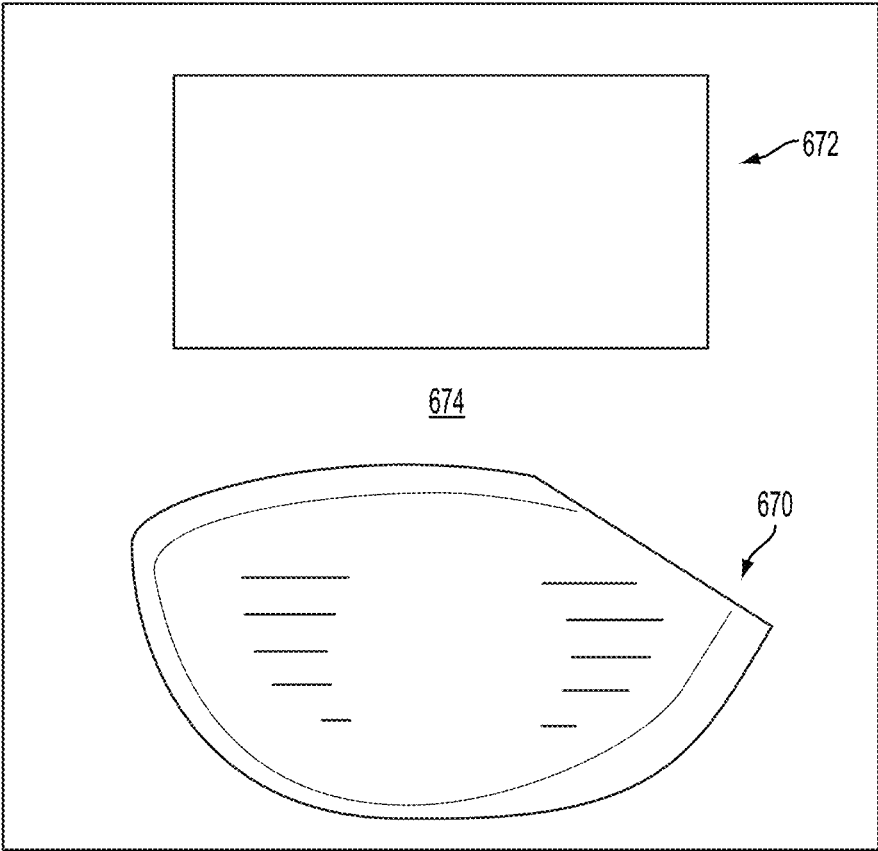

FIG. 31

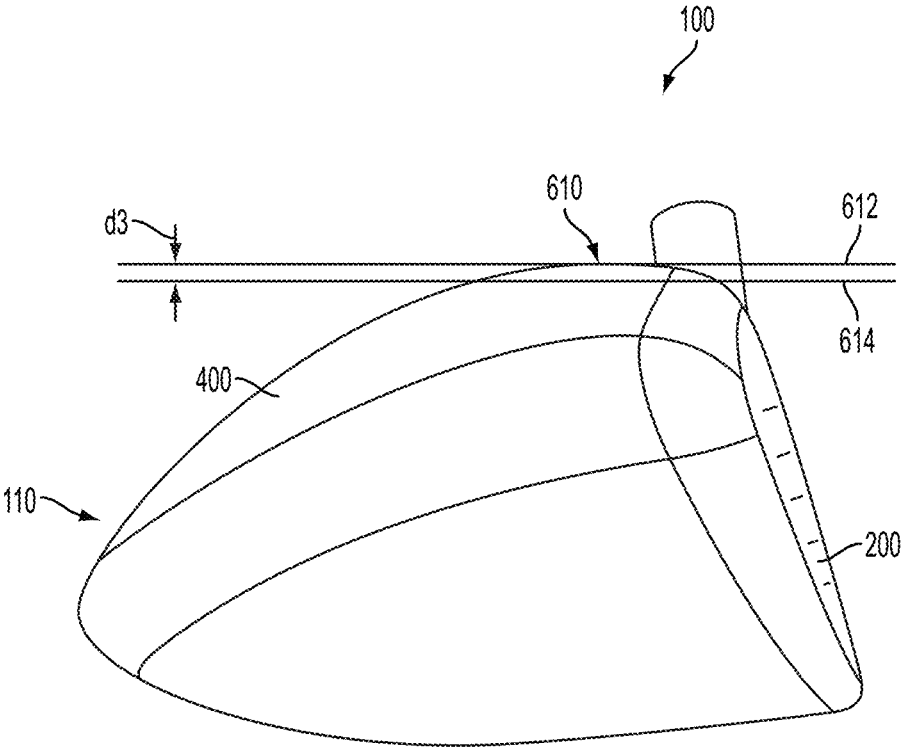

FIG. 32A

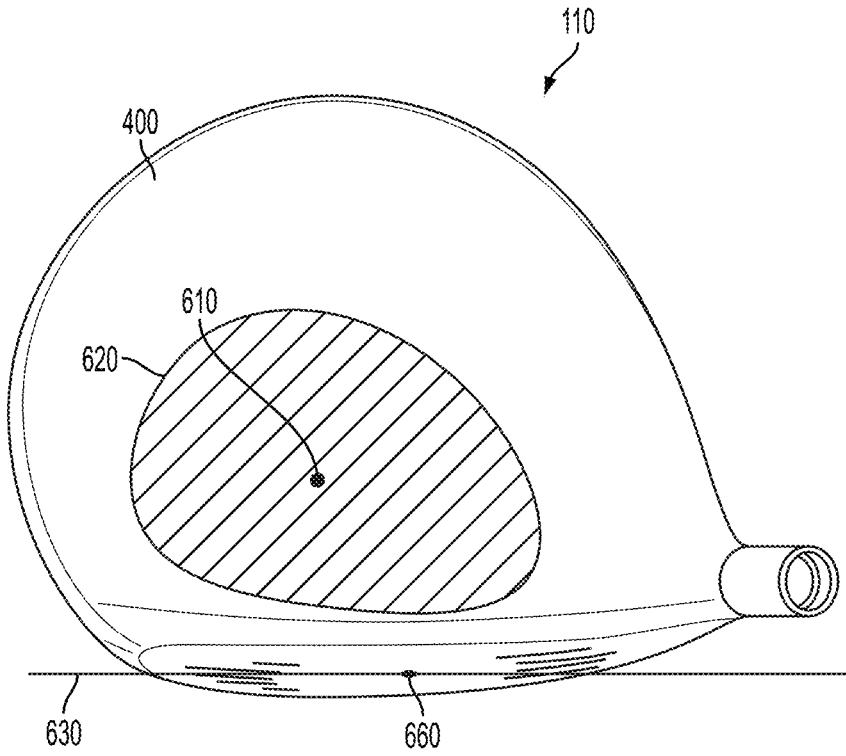

FIG. 32B

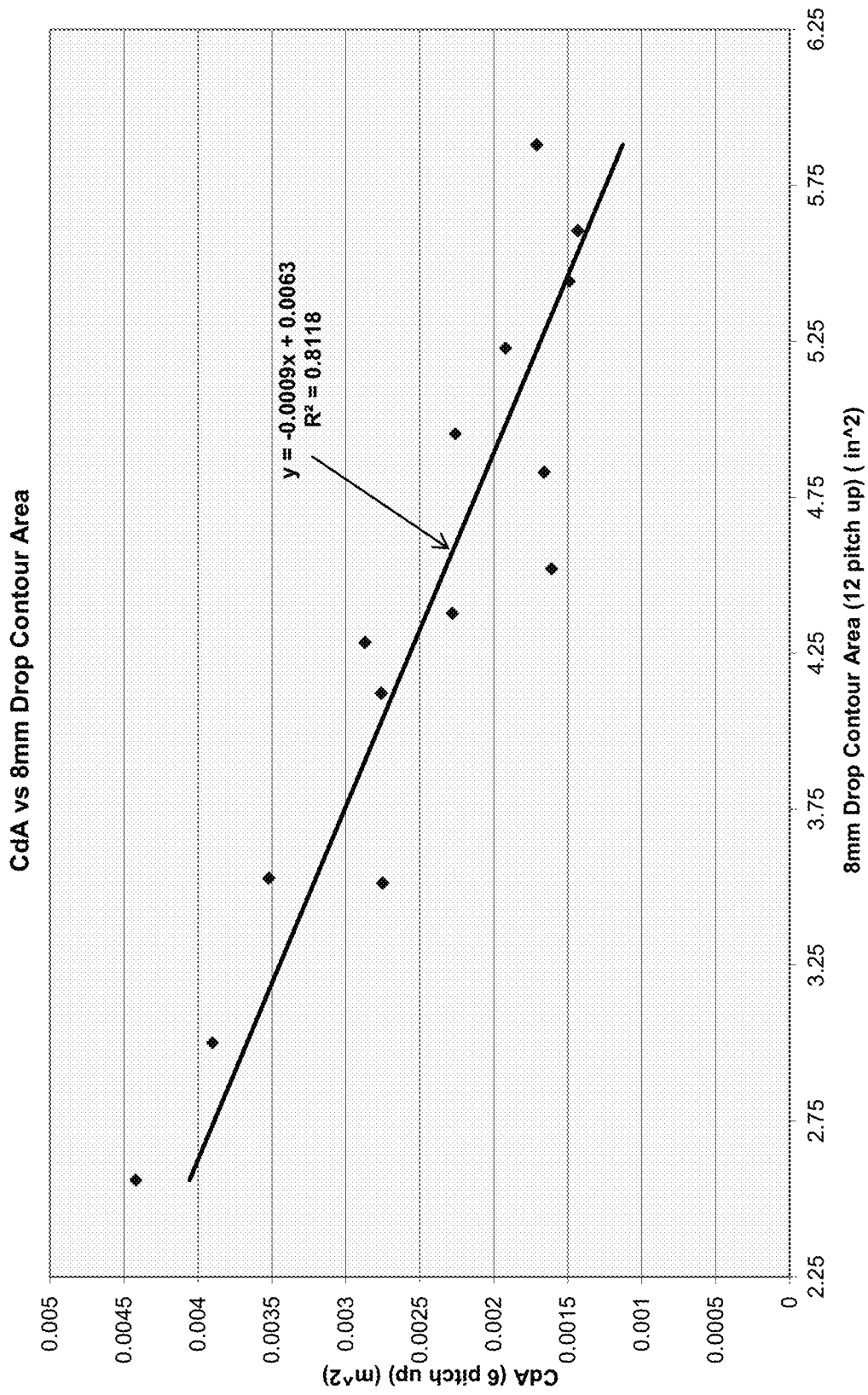

FIG. 33

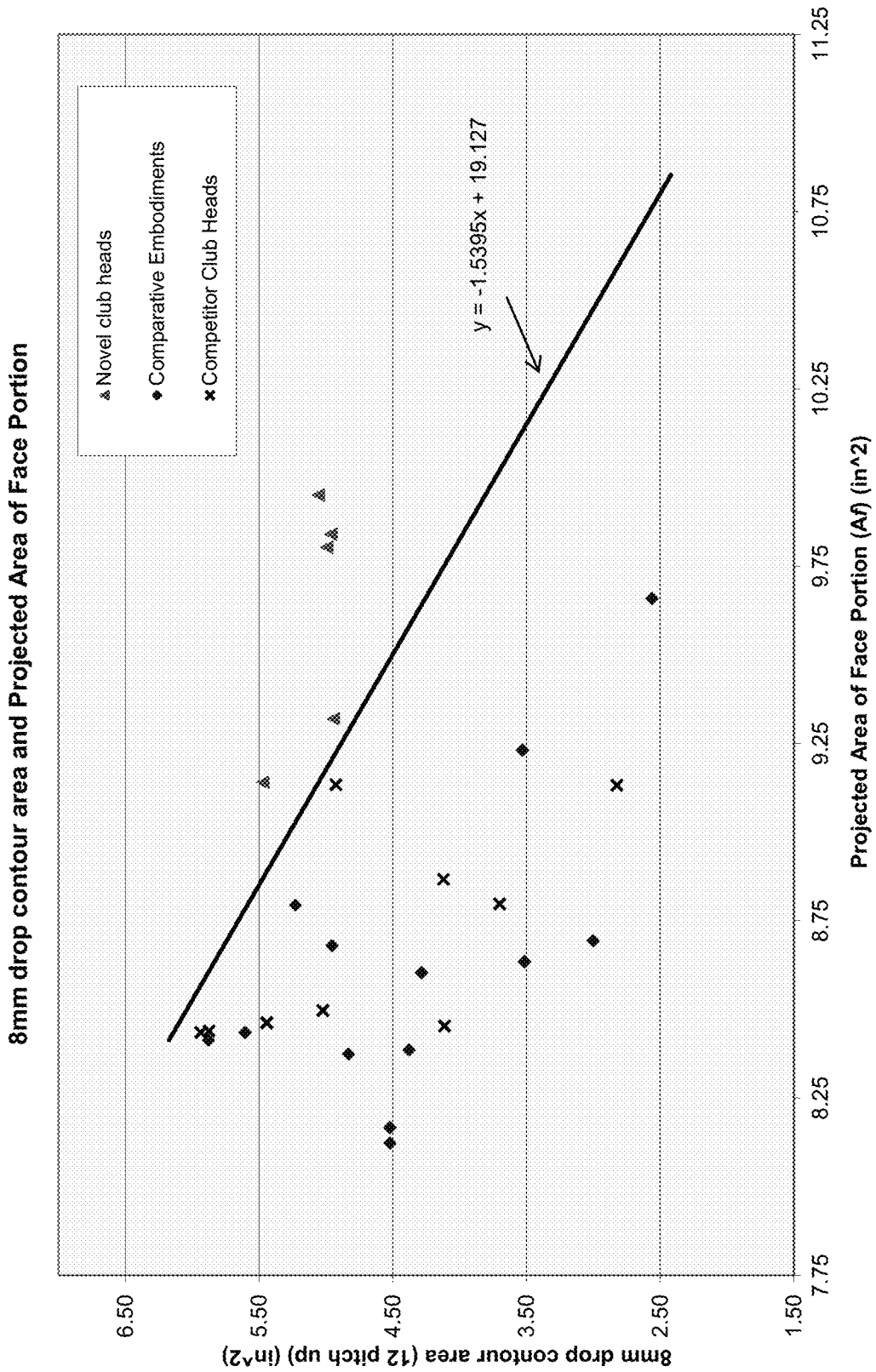

FIG. 34

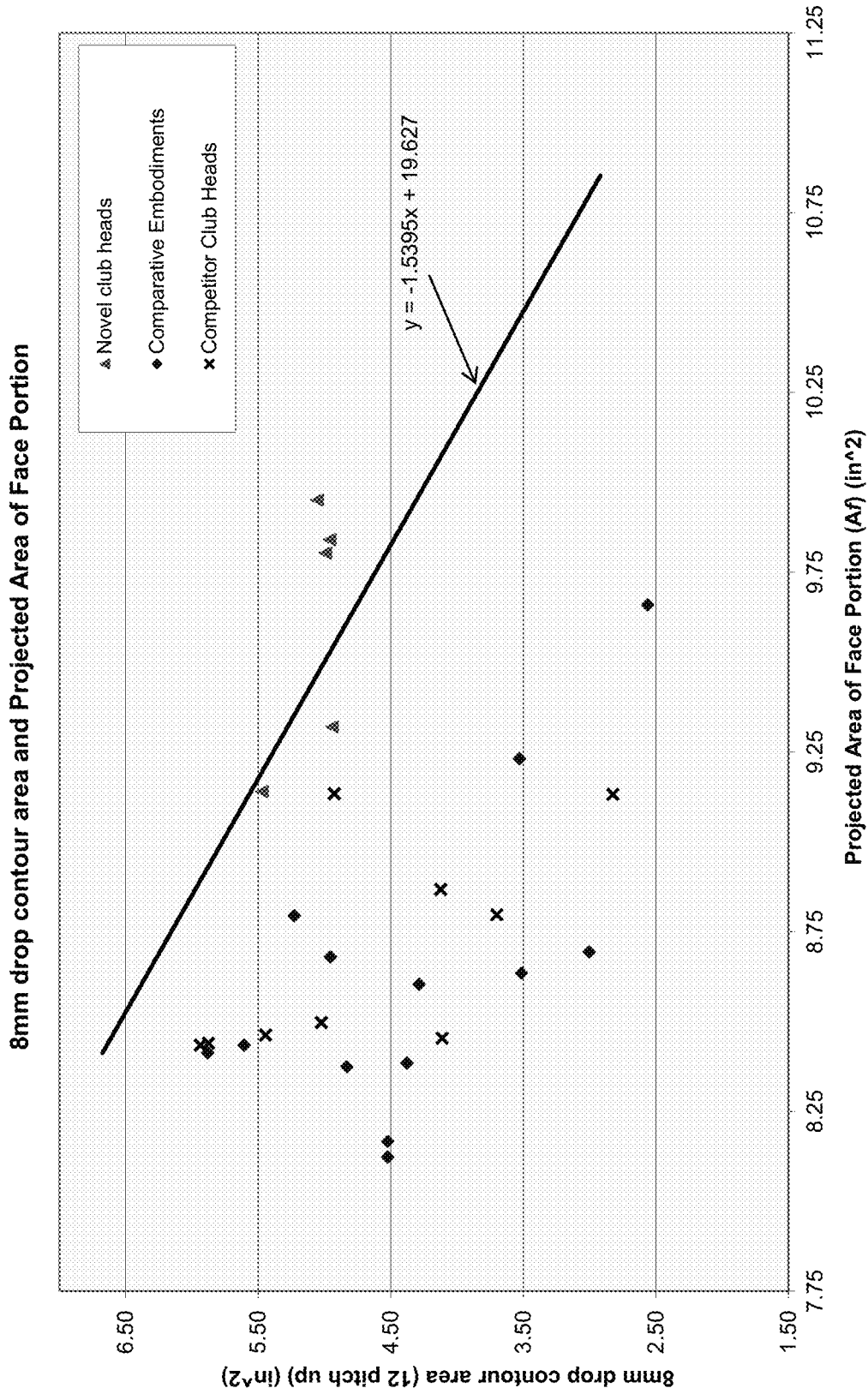

FIG. 35

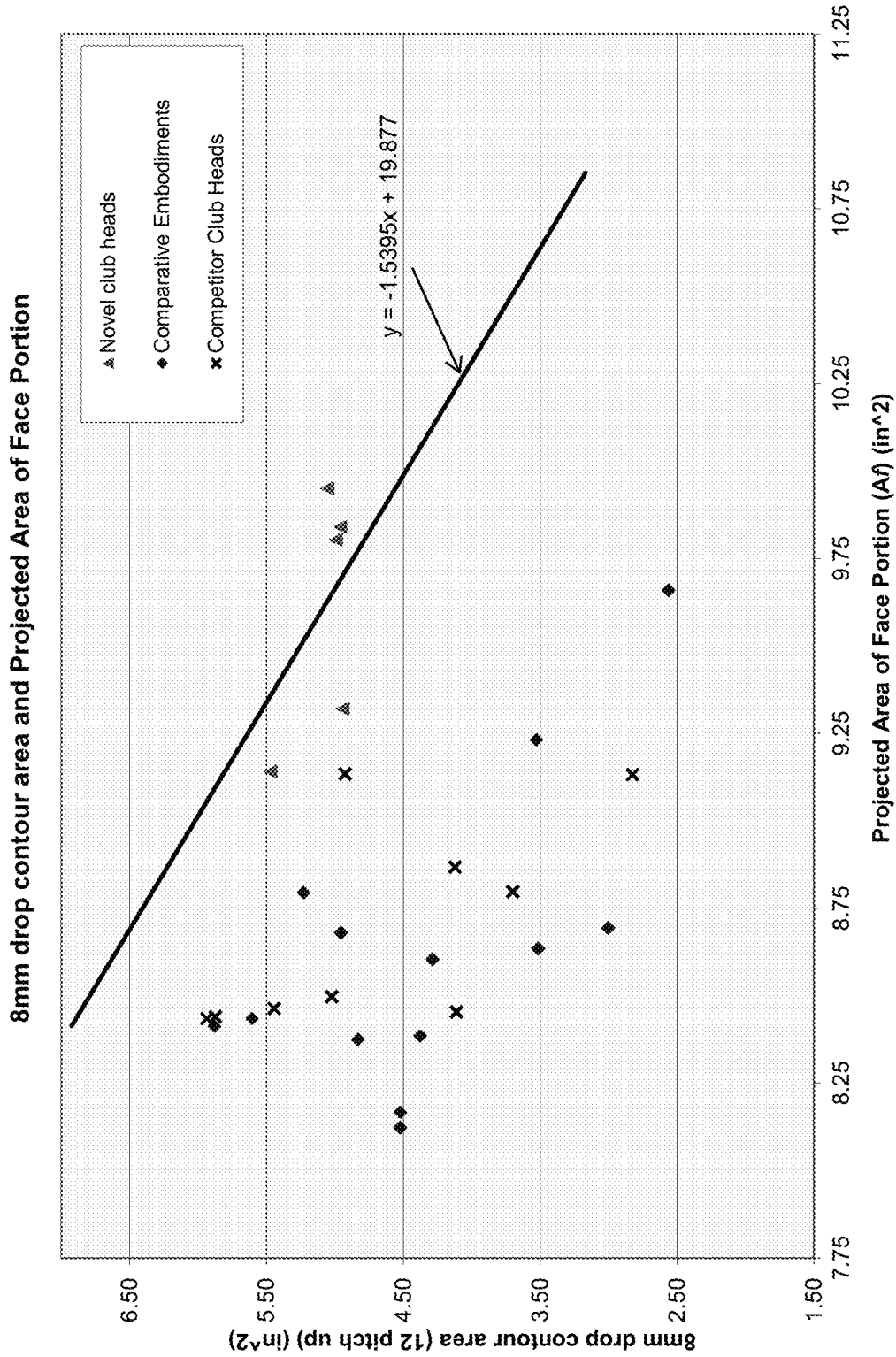

FIG. 36

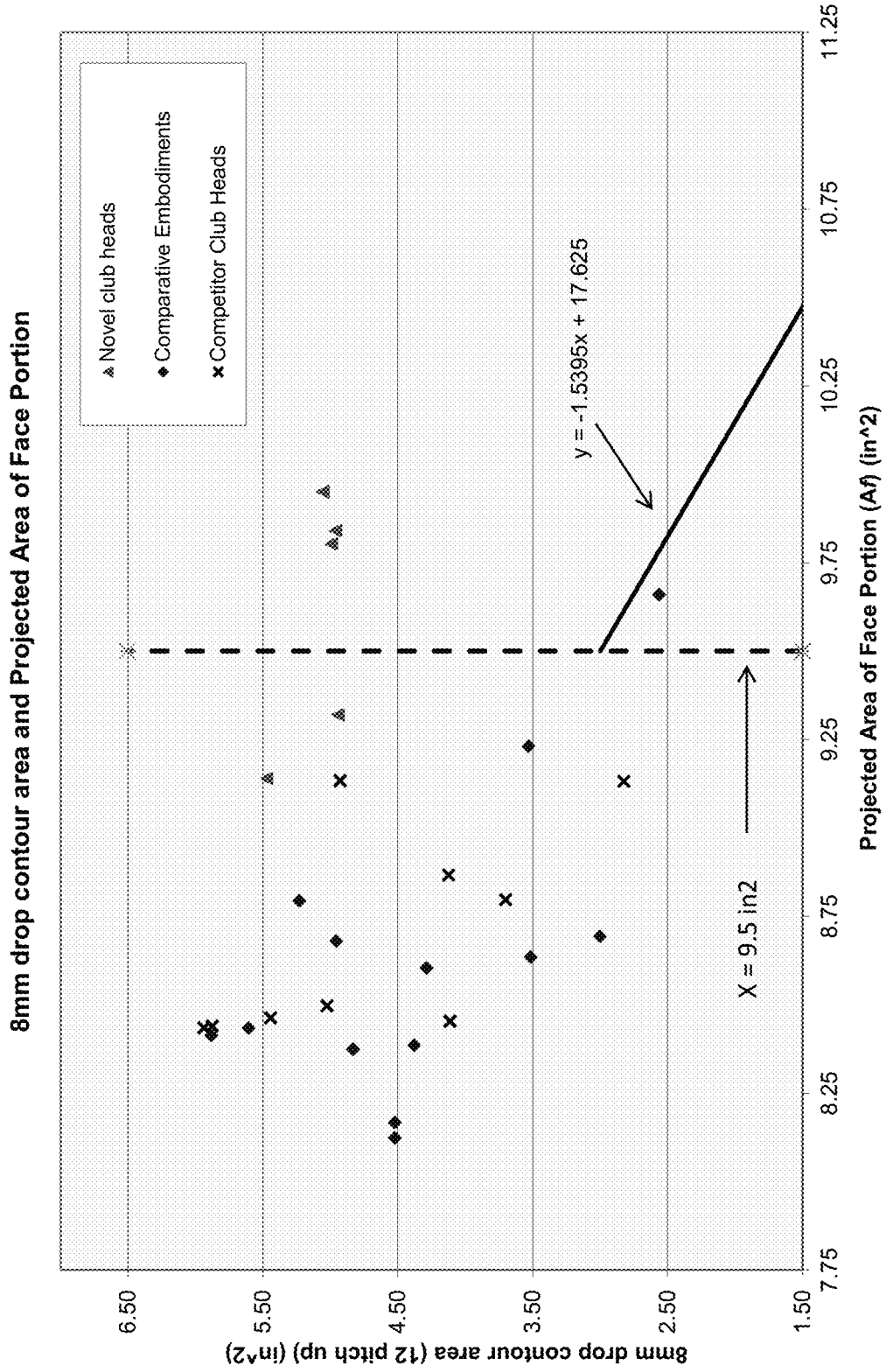

FIG. 37

8mm drop contour area and Projected Area of Face Portion

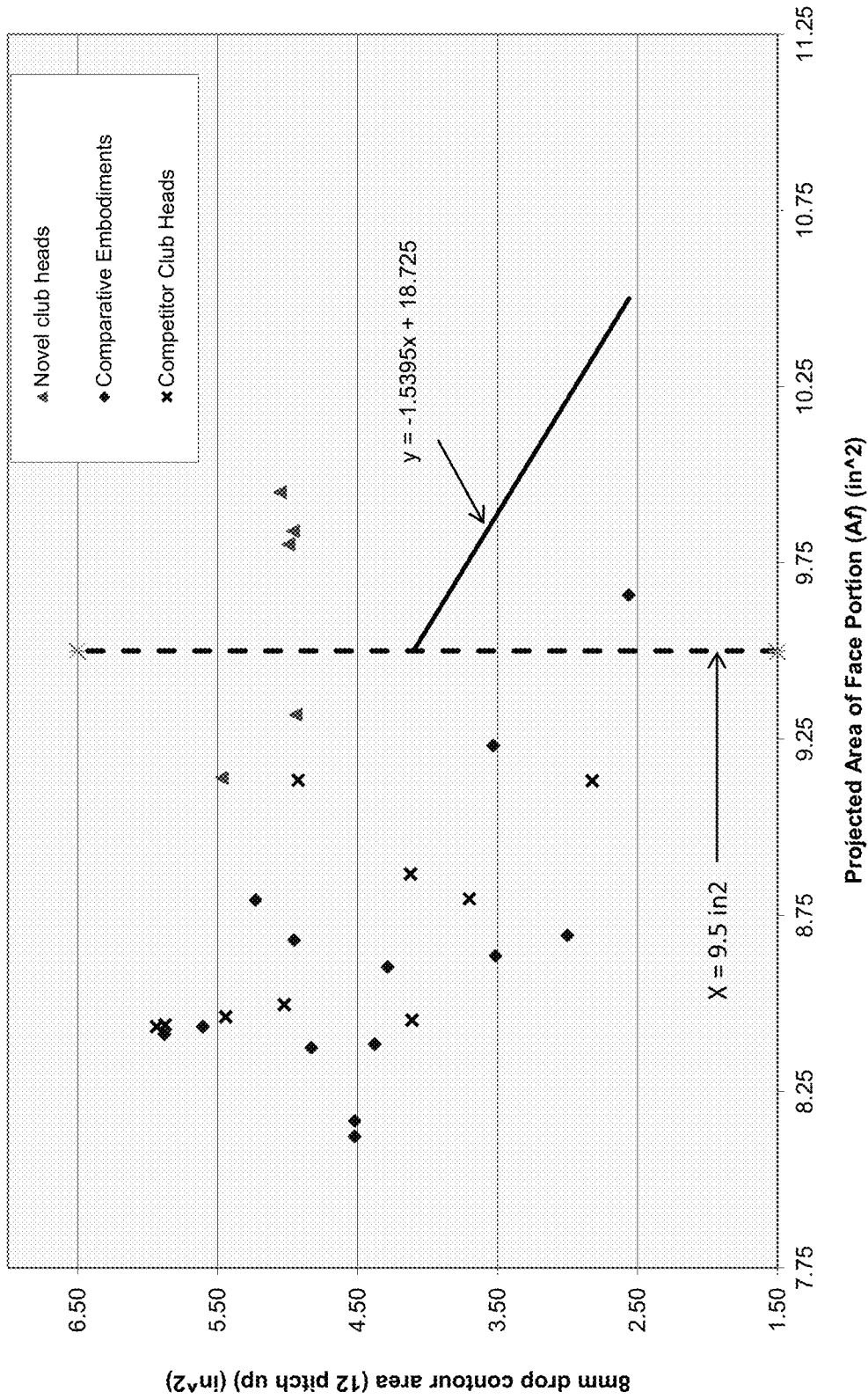

FIG. 38

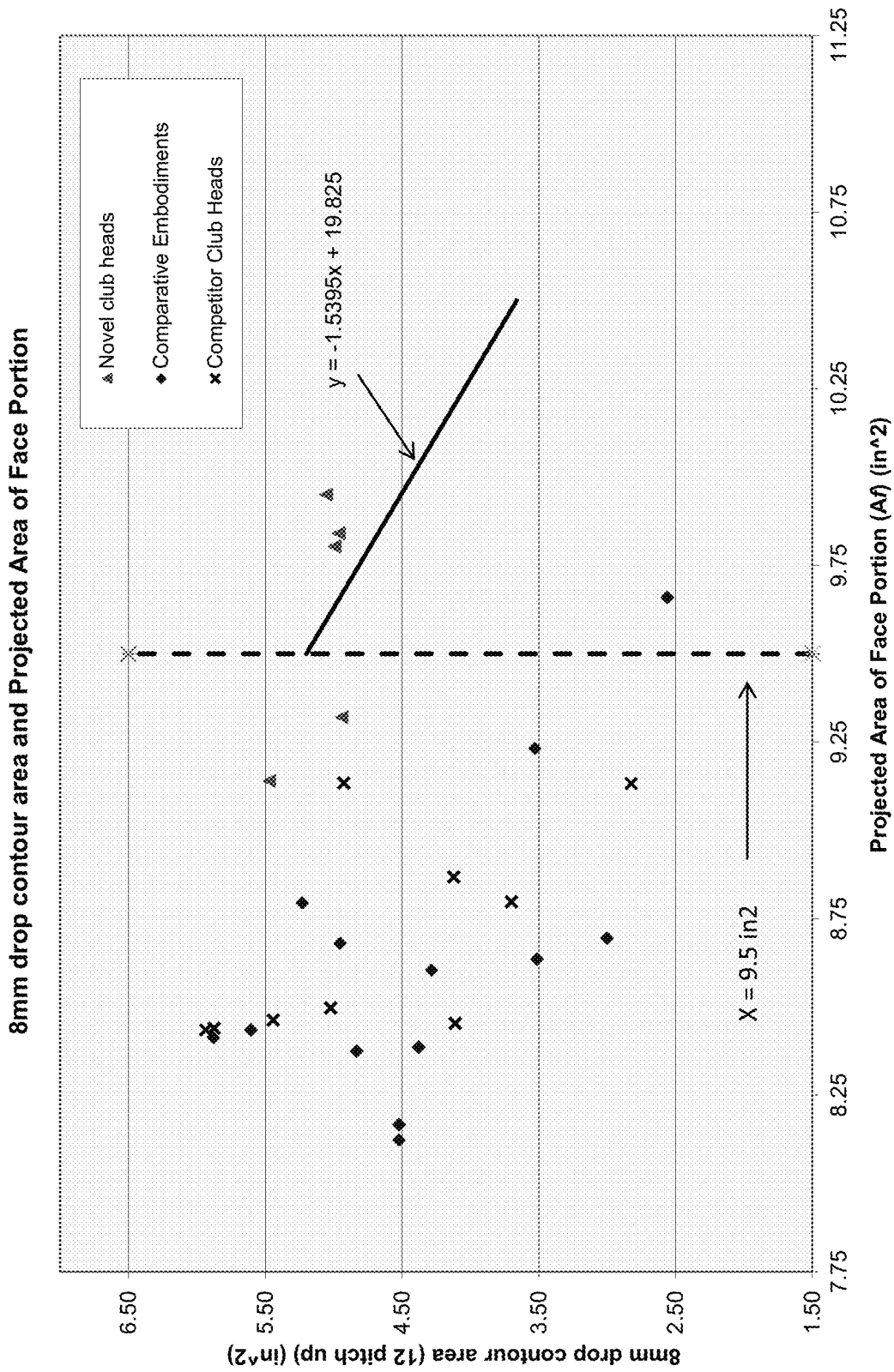

FIG. 39

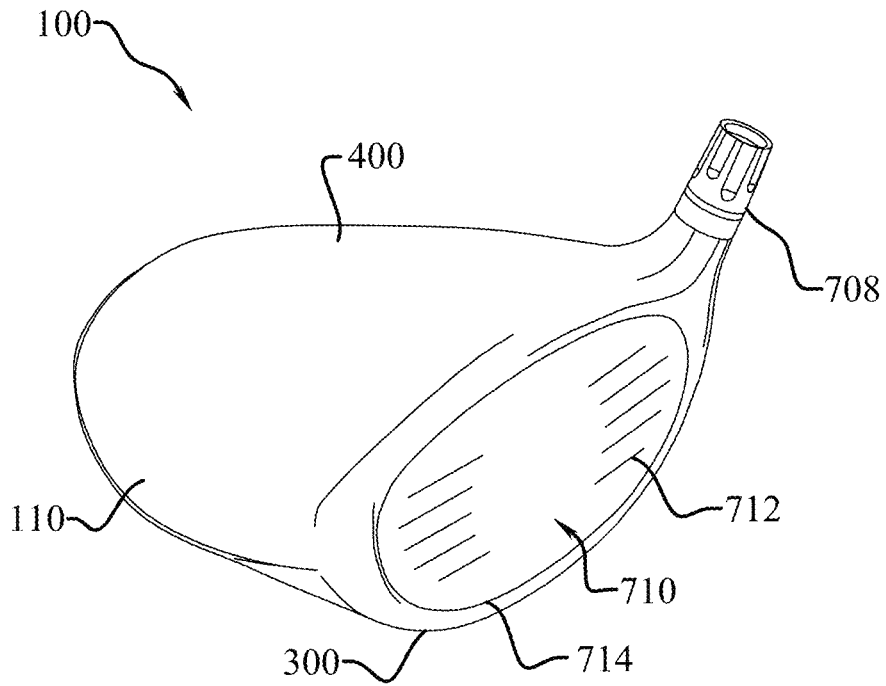

Fig. 40A

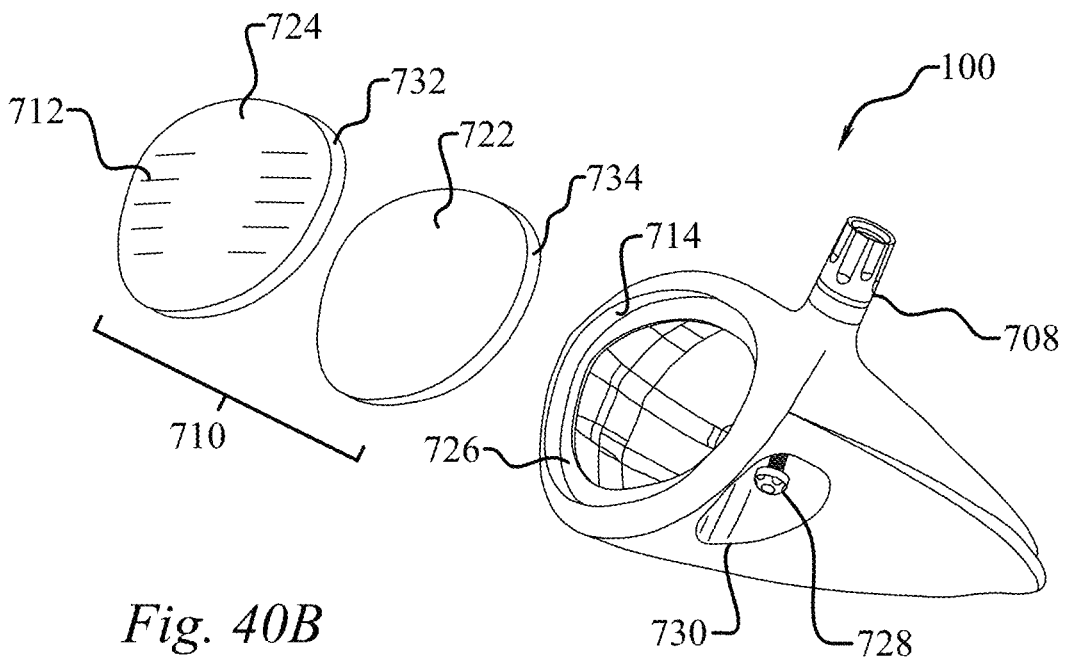

Fig. 40B

AERODYNAMIC GOLF CLUB HEAD

CROSS-REFERENCE TO RELATED APPLICATIONS

This application is a continuation of U.S. patent application Ser. No. 15/959,467, filed on Apr. 23, 2018, which is a continuation of U.S. patent application Ser. No. 15/456,630, filed on Mar. 13, 2017 (now U.S. Pat. No. 9,950,224), which is a continuation of U.S. patent application Ser. No. 15/002,471, filed on Jan. 21, 2016 (now U.S. Pat. No. 9,623,295), which is a continuation of U.S. patent application Ser. No. 14/488,354, filed on Sep. 17, 2014 (now U.S. Pat. No. 9,259,628), which is a continuation of U.S. patent application Ser. No. 13/718,107, filed on Dec. 18, 2012 (now U.S. Pat. No. 8,858,359), which is a continuation-in-part of U.S. patent application Ser. No. 13/683,299, filed on Nov. 21, 2012 (now U.S. Pat. No. 8,540,586), which is a continuation application of U.S. patent application Ser. No. 13/305,978, filed on Nov. 29, 2011, which is a continuation application of U.S. patent application Ser. No. 12/409,998, filed on Mar. 24, 2009 (now U.S. Pat. No. 8,088,021), which is a continuation-in-part of U.S. patent application Ser. No. 12/367,839, filed on Feb. 9, 2009 (now U.S. Pat. No. 8,083,609), which claims the benefit of U.S. provisional patent application Ser. No. 61/080,892, filed on Jul. 15, 2008, and U.S. provisional patent application Ser. No. 61/101,919, filed on Oct. 1, 2008, all of which are incorporated by reference as if completely written herein.

STATEMENT REGARDING FEDERALLY SPONSORED RESEARCH OR DEVELOPMENT

This invention was not made as part of a federally sponsored research or development project.

TECHNICAL FIELD

The present invention relates to sports equipment; particularly, to a high volume aerodynamic golf club head.

BACKGROUND OF THE INVENTION

Modern high volume golf club heads, namely drivers, are being designed with little, if any, attention paid to the aerodynamics of the golf club head. This stems in large part from the fact that in the past the aerodynamics of golf club heads were studied and it was found that the aerodynamics of the club head had only minimal impact on the performance of the golf club.

The drivers of today have club head volumes that are often double the volume of the most advanced club heads from just a decade ago. In fact, virtually all modern drivers have club head volumes of at least 400 cc, with a majority having volumes right at the present USGA mandated limit of 460 cc. Still, golf club designers pay little attention to the aerodynamics of these large golf clubs; often instead focusing solely on increasing the club head's resistance to twisting during off-center shots.

The modern race to design golf club heads that greatly resist twisting, meaning that the club heads have large moments of inertia, has led to club heads having very long front-to-back dimensions. The front-to-back dimension of a golf club head, often annotated the FB dimension, is measured from the leading edge of the club face to the furthest back portion of the club head. Currently, in addition to the USGA limit on the club head volume, the USGA limits the

front-to-back dimension (FB) to 5 inches and the moment of inertia about a vertical axis passing through the club head's center of gravity (CG), referred to as MOI_y, to 5900 g*cm². One of skill in the art will know the meaning of "center of gravity," referred to herein as CG, from an entry level course on mechanics. With respect to wood-type golf clubs, which are generally hollow and/or having non-uniform density, the CG is often thought of as the intersection of all the balance points of the club head. In other words, if you balance the head on the face and then on the sole, the intersection of the two imaginary lines passing straight through the balance points would define the point referred to as the CG.

Until just recently the majority of drivers had what is commonly referred to as a "traditional shape" and a 460 cc club head volume. These large volume traditional shape drivers had front-to-back dimensions (FB) of approximately 4.0 inches to 4.3 inches, generally achieving an MOI_y in the range of 4000-4600 g*cm². As golf club designers strove to increase MOI_y as much as possible, the FB dimension of drivers started entering the range of 4.3 inches to 5.0 inches. The graph of FIG. 1 shows the FB dimension and MOI_y of 83 different club head designs and nicely illustrates that high MOI_y values come with large FB dimensions.

While increasing the FB dimension to achieve higher MOI_y values is logical, significant adverse effects have been observed in these large FB dimension clubs. One significant adverse effect is a dramatic reduction in club head speed, which appears to have gone unnoticed by many in the industry. The graph of FIG. 2 illustrates player test data with drivers having an FB dimension greater than 3.6 inches. The graph illustrates considerably lower club head speeds for large FB dimension drivers when compared to the club head speeds of drivers having FB dimensions less than 4.4 inches. In fact, a club head speed of 104.6 mph was achieved when swinging a driver having a FB dimension of less than 3.8 inches, while the swing speed dropped over 3% to 101.5 mph when swinging a driver with a FB dimension of slightly less than 4.8 inches.

This significant decrease in club head speed is the result of the increase in aerodynamic drag forces associated with large FB dimension golf club heads. Data obtained during extensive wind tunnel testing shows a strong correlation between club head FB dimension and the aerodynamic drag measured at several critical orientations. First, orientation one is identified in FIG. 11 with a flow arrow labeled as "Air Flow—90°" and is referred to in the graphs of the figures as "lie 90 degree orientation." This orientation can be thought of as the club head resting on the ground plane (GP) with the shaft axis (SA) at the club head's design lie angle, as seen in FIG. 8. Then a 100 mph wind is directed parallel to the ground plane (GP) directly at the club face (200), as illustrated by the flow arrow labeled "Air Flow—90°" in FIG. 11. Secondly, orientation two is identified in FIG. 11 with a flow arrow labeled as "Air Flow—60°" and is referred to in the graphs of the figures as "lie 60 degree orientation." This orientation can be thought of as the club head resting on the ground plane (GP) with the shaft axis (SA) at the club head's design lie angle, as seen in FIG. 8. Then a 100 mph wind is wind is oriented thirty degrees from a vertical plane normal to the face (200) with the wind originating from the heel (116) side of the club head, as illustrated by the flow arrow labeled "Air Flow—60°" in FIG. 11.

Thirdly, orientation three is identified in FIG. 12 with a flow arrow labeled as "Air Flow—Vert.—0°" and is referred to in the graphs of the figures as "vertical 0 degree orientation." This orientation can be thought of as the club head being oriented upside down with the shaft axis (SA) vertical

while being exposed to a horizontal 100 mph wind directed at the heel (116), as illustrated by the flow arrow labeled "Air Flow—Vert.—0°" in FIG. 12. Thus, the air flow is parallel to the vertical plane created by the shaft axis (SA) seen in FIG. 11, blowing from the heel (116) to the toe (118) but with the club head oriented as seen in FIG. 12.

Now referring back to orientation one, namely the orientation identified in FIG. 11 with a flow arrow labeled as "Air Flow—90°." Normalized aerodynamic drag data has been gathered for six different club heads and is illustrated in the graph of FIG. 5. At this point it is important to understand that all of the aerodynamic drag forces mentioned herein, unless otherwise stated, are aerodynamic drag forces normalized to a 120 mph airstream velocity. Thus, the illustrated aerodynamic drag force values are the actual measured drag force at the indicated airstream velocity multiplied by the square of the reference velocity, which is 120 mph, then divided by the square of the actual airstream velocity. Therefore, the normalized aerodynamic drag force plotted in FIG. 5 is the actual measured drag force when subjected to a 100 mph wind at the specified orientation, multiplied by the square of the 120 mph reference velocity, and then divided by the square of the 100 mph actual airstream velocity.

Still referencing FIG. 5, the normalized aerodynamic drag force increases non-linearly from a low of 1.2 lbf with a short 3.8 inch FB dimension club head to a high of 2.65 lbf for a club head having a FB dimension of almost 4.8 inches. The increase in normalized aerodynamic drag force is in excess of 120% as the FB dimension increases slightly less than one inch, contributing to the significant decrease in club head speed previously discussed.

The results are much the same in orientation two, namely the orientation identified in FIG. 11 with a flow arrow labeled as "Air Flow—60°." Again, normalized aerodynamic drag data has been gathered for six different club heads and is illustrated in the graph of FIG. 4. The normalized aerodynamic drag force increases non-linearly from a low of approximately 1.1 lbf with a short 3.8 inch FB dimension club head to a high of approximately 1.9 lbf for a club head having a FB dimension of almost 4.8 inches. The increase in normalized aerodynamic drag force is almost 73% as the FB dimension increases slightly less than one inch, also contributing to the significant decrease in club head speed previously discussed.

Again, the results are much the same in orientation three, namely the orientation identified in FIG. 12 with a flow arrow labeled as "Air Flow—Vert.—0°." Again, normalized aerodynamic drag data has been gathered for several different club heads and is illustrated in the graph of FIG. 3. The normalized aerodynamic drag force increases non-linearly from a low of approximately 1.15 lbf with a short 3.8 inch FB dimension club head to a high of approximately 2.05 lbf for a club head having a FB dimension of almost 4.8 inches. The increase in normalized aerodynamic drag force is in excess of 78% as the FB dimension increases slightly less than one inch, also contributing to the significant decrease in club head speed previously discussed.

Further, the graph of FIG. 6 correlates the player test club head speed data of FIG. 2 with the maximum normalized aerodynamic drag force for each club head from FIG. 3, 4, or 5. Thus, FIG. 6 shows that the club head speed drops from 104.6 mph, when the maximum normalized aerodynamic drag force is only 1.2 lbf, down to 101.5 mph, when the maximum normalized aerodynamic drag force is 2.65 lbf.

The drop in club head speed just described has a significant impact on the speed at which the golf ball leaves the

club face after impact and thus the distance that the golf ball travels. In fact, for a club head speed of approximately 100 mph, each 1 mph reduction in club head speed results in approximately a 1% loss in distance. The present golf club head has identified these relationships, the reason for the drop in club head speed associated with long FB dimension clubs, and several ways to reduce the aerodynamic drag force of golf club heads.

SUMMARY OF THE INVENTION

The claimed aerodynamic golf club head having a large projected area of the face portion (A_f) and large drop contour area (CA) has recognized that the poor aerodynamic performance of large FB dimension drivers is not due solely to the large FB dimension; rather, in an effort to create large FB dimension drivers with a high MOI_y value and low center of gravity (CG) dimension, golf club designers have generally created clubs that have very poor aerodynamic shaping. Several problems are the lack of proper shaping to account for airflow reattachment in the crown area trailing the face, the lack of proper shaping to promote airflow attachment after it passes the highest point on the crown, and the lack of proper trailing edge design. In addition, current driver designs have failed to obtain improved aerodynamic performance for golf club head designs that include a large projected area of the face portion (A_f).

The present aerodynamic golf club head having a large projected area of the face portion (A_f) and large drop contour area (CA) solves these issues and results in a high volume aerodynamic golf club head having a relatively large FB dimension with beneficial moment of inertia values, while also obtaining superior aerodynamic properties unseen by other large volume, large FB dimension, high MOI_y golf club heads. The golf club head obtains superior aerodynamic performance through the use of unique club head shapes and the incorporation of crown section having a drop contour area (CA) that is sufficiently large in relation to the projected area of the face portion (A_f) of the golf club head.

The club head has a large projected area of the face portion (A_f) and a crown having a large drop contour area (CA). The drop contour area (CA) is an area defined by the intersection of the crown with a plane that is offset toward the ground plane from the crown apex. In several embodiments, the relationship between the projected area of the face portion (A_f) and the drop contour area (CA) is defined in part by linear boundary equation. The relatively large drop contour area (CA) for a given relatively large projected area of the face portion (A_f) aids in keeping airflow attached to the club head once it flows past the crown apex thereby resulting in reduced aerodynamic drag forces and producing higher club head speeds.

BRIEF DESCRIPTION OF THE DRAWINGS

Without limiting the scope of the present aerodynamic golf club head as claimed below and referring now to the drawings and figures:

FIG. 1 shows a graph of FB dimensions versus MOI_y;

FIG. 2 shows a graph of FB dimensions versus club head speed;

FIG. 3 shows a graph of FB dimensions versus club head normalized aerodynamic drag force;

FIG. 4 shows a graph of FB dimensions versus club head normalized aerodynamic drag force;

FIG. 5 shows a graph of FB dimensions versus club head normalized aerodynamic drag force;

5

FIG. 6 shows a graph of club head normalized aerodynamic drag force versus club head speed;

FIG. 7 shows a top plan view of a high volume aerodynamic golf club head, not to scale;

FIG. 8 shows a front elevation view of a high volume aerodynamic golf club head, not to scale;

FIG. 9 shows a toe side elevation view of a high volume aerodynamic golf club head, not to scale;

FIG. 10 shows a front elevation view of a high volume aerodynamic golf club head, not to scale;

FIG. 11 shows a top plan view of a high volume aerodynamic golf club head, not to scale;

FIG. 12 shows a rotated front elevation view of a high volume aerodynamic golf club head with a vertical shaft axis orientation, not to scale;

FIG. 13 shows a front elevation view of a high volume aerodynamic golf club head, not to scale;

FIG. 14 shows a top plan view of a high volume aerodynamic golf club head having a post apex attachment promoting region, not to scale;

FIG. 15 shows a top plan view of a high volume aerodynamic golf club head having a post apex attachment promoting region, not to scale;

FIG. 16 shows a top plan view of a high volume aerodynamic golf club head having a post apex attachment promoting region, not to scale;

FIG. 17 shows a top plan view of a high volume aerodynamic golf club head having a post apex attachment promoting region, not to scale;

FIG. 18 shows a partial isometric view of a high volume aerodynamic golf club head having a post apex attachment promoting region intersected by the maximum top edge plane, not to scale;

FIG. 19 shows a cross-sectional view taken through a center of the face of a high volume aerodynamic golf club head having a post apex attachment promoting region, not to scale;

FIG. 20 shows a cross-sectional view taken through a center of the face of a high volume aerodynamic golf club head having a post apex attachment promoting region, not to scale;

FIG. 21 shows a heel-side elevation view of a high volume aerodynamic golf club head having a post apex attachment promoting region, not to scale;

FIG. 22 shows a toe-side elevation view of a high volume aerodynamic golf club head having a post apex attachment promoting region, not to scale;

FIG. 23 shows a rear elevation view of a high volume aerodynamic golf club head having a post apex attachment promoting region, not to scale;

FIG. 24 shows a bottom plan view of a high volume aerodynamic golf club head having a post apex attachment promoting region, not to scale;

FIG. 25 shows a top plan view of a high volume aerodynamic golf club head having a post apex attachment promoting region, not to scale;

FIGS. 26A-C show respective orthogonal views depicting a high volume aerodynamic golf club head having a face and depicting a manner in which the face transitions into the contour of the body of the club head, not to scale;

FIG. 27 shows a front elevational view of a high volume aerodynamic golf club head, depicting the manner of defining a first cut plane in the method for obtaining a face portion of the club head for obtaining a standard measurement, as disclosed herein, of projected area of the face portion, not to scale;

6

FIG. 28 shows a front elevational view of the club head of FIG. 27, depicting a face on which a face center has been defined as part of the method for obtaining a face portion, not to scale;

FIG. 29 shows a top view of the club head of FIG. 27, depicting the manner of defining a second cut plane in the method for obtaining a face portion, not to scale;

FIG. 30A shows a front elevational view of the club head of FIG. 27, depicting the first cut plane, used in the method for obtaining a face portion, not to scale;

FIG. 30B shows a front elevational view of the face portion produced according to the method, not to scale;

FIG. 31 shows a schematic view of a reference surface (having a precisely known area) and a face portion positioned for obtaining a determination of the projected area of the face portion, not to scale;

FIG. 32A shows a toe-side elevation view of a high volume aerodynamic golf club head in a 12 degree pitched up orientation, not to scale;

FIG. 32B shows a top plan view of the high volume aerodynamic golf club head of FIG. 32A illustrating an 8 mm drop contour area, not to scale;

FIG. 33 shows a graph of 8 mm drop contour area (CA) versus the product of the drag coefficient (Cd) and the effective cross-sectional area (A);

FIGS. 34-39 show graphs of projected area of the face portion (Af) versus 8 mm drop contour area (CA);

FIG. 40A is an isometric view of a high volume aerodynamic golf club head having a composite face insert, not to scale; and

FIG. 40B is an exploded view of the high volume aerodynamic golf club head of FIG. 40A, not to scale.

These drawings are provided to assist in the understanding of the exemplary embodiments of the high volume aerodynamic golf club head as described in more detail below and should not be construed as unduly limiting the present golf club head. In particular, the relative spacing, positioning, sizing and dimensions of the various elements illustrated in the drawings are not drawn to scale and may have been exaggerated, reduced or otherwise modified for the purpose of improved clarity. Those of ordinary skill in the art will also appreciate that a range of alternative configurations have been omitted simply to improve the clarity and reduce the number of drawings.

DETAILED DESCRIPTION OF THE INVENTION

The claimed high volume aerodynamic golf club head (100) enables a significant advance in the state of the art. The preferred embodiments of the club head (100) accomplish this by new and novel arrangements of elements and methods that are configured in unique and novel ways and which demonstrate previously unavailable but preferred and desirable capabilities. The description set forth below in connection with the drawings is intended merely as a description of the presently preferred embodiments of the club head (100), and is not intended to represent the only form in which the club head (100) may be constructed or utilized. The description sets forth the designs, functions, means, and methods of implementing the club head (100) in connection with the illustrated embodiments. It is to be understood, however, that the same or equivalent functions and features may be accomplished by different embodiments that are also intended to be encompassed within the spirit and scope of the club head (100).

The present high volume aerodynamic golf club head (100) has recognized that the poor aerodynamic performance of large FB dimension drivers is not due solely to the large FB dimension; rather, in an effort to create large FB dimension drivers with a high MOI_y value and low center of gravity (CG) dimension, golf club designers have generally created clubs that have very poor aerodynamic shaping. The main problems are the significantly flat surfaces on the body, the lack of proper shaping to account for airflow reattachment in the crown area trailing the face, and the lack of proper trailing edge design. In addition, current large FB dimension driver designs have ignored, or even tried to maximize in some cases, the frontal cross sectional area of the golf club head which increases the aerodynamic drag force. The present aerodynamic golf club head (100) solves these issues and results in a high volume aerodynamic golf club head (100) having a large FB dimension and a high MOI_y.

The present high volume aerodynamic golf club head (100) has a volume of at least 400 cc. It is characterized by a face-on normalized aerodynamic drag force of less than 1.5 lbf when exposed to a 100 mph wind parallel to the ground plane (GP) when the high volume aerodynamic golf club head (100) is positioned in a design orientation and the wind is oriented at the front (112) of the high volume aerodynamic golf club head (100), as previously described with respect to FIG. 11 and the flow arrow labeled "air flow—90°." As explained in the "Background" section, but worthy of repeating in this section, all of the aerodynamic drag forces mentioned herein, unless otherwise stated, are aerodynamic drag forces normalized to a 120 mph airstream velocity. Thus, the above mentioned normalized aerodynamic drag force of less than 1.5 lbf when exposed to a 100 mph wind is the actual measured drag force at the indicated 100 mph airstream velocity multiplied by the square of the reference velocity, which is 120 mph, then divided by the square of the actual airstream velocity, which is 100 mph.

With general reference to FIGS. 7-9, the high volume aerodynamic golf club head (100) includes a hollow body (110) having a face (200), a sole section (300), and a crown section (400). The hollow body (110) may be further defined as having a front (112), a back (114), a heel (116), and a toe (118). Further, the hollow body (110) has a front-to-back dimension (FB) of at least 4.4 inches, as previously defined and illustrated in FIG. 7.

The relatively large FB dimension of the present high volume aerodynamic golf club head (100) aids in obtaining beneficial moment of inertia values while also obtaining superior aerodynamic properties unseen by other large volume, large FB dimension, high MOI golf club heads. Specifically, an embodiment of the high volume aerodynamic golf club head (100) obtains a first moment of inertia (MOI_y) about a vertical axis through a center of gravity (CG) of the golf club head (100), illustrated in FIG. 7, that is at least 4000 g*cm². MOI_y is the moment of inertia of the golf club head (100) that resists opening and closing moments induced by ball strikes towards the toe side or heel side of the face. Further, this embodiment obtains a second moment of inertia (MOI_x) about a horizontal axis through the center of gravity (CG), as seen in FIG. 9, that is at least 2000 g*cm². MOI_x is the moment of inertia of the golf club head (100) that resists lofting and delofting moments induced by ball strikes high or low on the face (200).

The golf club head (100) obtains superior aerodynamic performance through the use of unique club head shapes. Referring now to FIG. 8, the crown section (400) has a crown apex (410) located an apex height (AH) above a

ground plane (GP). The apex height (AH), as well as the location of the crown apex (410), play important roles in obtaining desirable airflow reattachment as close to the face (200) as possible, as well as improving the airflow attachment to the crown section (400). With reference now to FIGS. 9 and 10, the crown section (400) has three distinct radii that improve the aerodynamic performance of the present club head (100). First, as seen in FIG. 9, a portion of the crown section (400) between the crown apex (410) and the front (112) has an apex-to-front radius of curvature (Ra-f) that is less than 3 inches. The apex-to-front radius of curvature (Ra-f) is measured in a vertical plane that is perpendicular to a vertical plane passing through the shaft axis (SA), and the apex-to-front radius of curvature (Ra-f) is further measured at the point on the crown section (400) between the crown apex (410) and the front (112) that has the smallest the radius of curvature. In one particular embodiment, at least fifty percent of the vertical plane cross sections taken perpendicular to a vertical plane passing through the shaft axis (SA), which intersect a portion of a face top edge (210), are characterized by an apex-to-front radius of curvature (Ra-f) of less than 3 inches. In still a further embodiment, at least ninety percent of the vertical plane cross sections taken perpendicular to a vertical plane passing through the shaft axis (SA), which intersect a portion of the face top edge (210), are characterized by an apex-to-front radius of curvature (Ra-f) of less than 3 inches. In yet another embodiment, at least fifty percent of the vertical plane cross sections taken perpendicular to a vertical plane passing through the shaft axis (SA), which intersect a portion of the face top edge (210) between the center of the face (200) and the toward most point on the face (200), are characterized by an apex-to-front radius of curvature (Ra-f) of less than 3 inches. Still further, another embodiment has at least fifty percent of the vertical plane cross sections taken perpendicular to a vertical plane passing through the shaft axis (SA), which intersect a portion of the face top edge (210) between the center of the face (200) and the toward most point on the face (200), are characterized by an apex-to-front radius of curvature (Ra-f) of less than 3 inches.

The center of the face (200) shall be determined in accordance with the USGA "Procedure for Measuring the Flexibility of a Golf Clubhead," Revision 2.0, Mar. 25, 2005, which is incorporated herein by reference. This USGA procedure identifies a process for determining the impact location on the face of a golf club that is to be tested, also referred therein as the face center. The USGA procedure utilizes a template that is placed on the face of the golf club to determine the face center.

Secondly, a portion of the crown section (400) between the crown apex (410) and the back (114) of the hollow body (110) has an apex-to-rear radius of curvature (Ra-r) that is less than 3.75 inches. The apex-to-rear radius of curvature (Ra-r) is also measured in a vertical plane that is perpendicular to a vertical plane passing through the shaft axis (SA), and the apex-to-rear radius of curvature (Ra-r) is further measured at the point on the crown section (400) between the crown apex (410) and the back (114) that has the smallest the radius of curvature. In one particular embodiment, at least fifty percent of the vertical plane cross sections taken perpendicular to a vertical plane passing through the shaft axis (SA), which intersect a portion of the face top edge (210), are characterized by an apex-to-rear radius of curvature (Ra-r) of less than 3.75 inches. In still a further embodiment, at least ninety percent of the vertical plane cross sections taken perpendicular to a vertical plane passing through the shaft axis (SA), which intersect a

portion of the face top edge (210), are characterized by an apex-to-rear radius of curvature (Ra-r) of less than 3.75 inches. In yet another embodiment, one hundred percent of the vertical plane cross sections taken perpendicular to a vertical plane passing through the shaft axis (SA), which intersect a portion of the face top edge (210) between the center of the face (200) and the toward most point on the face (200), are characterized by an apex-to-rear radius of curvature (Ra-r) of less than 3.75 inches.

Lastly, as seen in FIG. 10, a portion of the crown section (400) has a heel-to-toe radius of curvature (Rh-t) at the crown apex (410) in a direction parallel to the vertical plane created by the shaft axis (SA) that is less than 4 inches. In a further embodiment, at least ninety percent of the crown section (400) located between the most heelward point on the face (200) and the most toward point on the face (200) has a heel-to-toe radius of curvature (Rh-t) at the crown apex (410) in a direction parallel to the vertical plane created by the shaft axis (SA) that is less than 4 inches. A further embodiment has one hundred percent of the crown section (400) located between the most heelward point on the face (200) and the most toward point on the face (200) exhibiting a heel-to-toe radius of curvature (Rh-t), at the crown apex (410) in a direction parallel to the vertical plane created by the shaft axis (SA), that is less than 4 inches.

Such small radii of curvature exhibited in the embodiments described herein have traditionally been avoided in the design of high volume golf club heads, especially in the design of high volume golf club heads having FB dimensions of 4.4 inches and greater. However, it is these tight radii produce a bulbous crown section (400) that facilitates airflow reattachment as close to the face (200) as possible, thereby resulting in reduced aerodynamic drag forces and facilitating higher club head speeds.

Conventional high volume large MOly golf club heads having large FB dimensions, such as those seen in U.S. Pat. No. D544,939 and U.S. Pat. No. D543,600, have relatively flat crown sections that often never extend above the face. While these designs appear as though they should cut through the air, the opposite is often true with such shapes achieving poor airflow reattachment characteristics and increased aerodynamic drag forces. The present club head (100) has recognized the significance of proper club head shaping to account for rapid airflow reattachment in the crown section (400) trailing the face (200), which is quite the opposite of the flat steeply sloped crown sections of many prior art large FB dimension club heads.

With reference now to FIG. 10, the face (200) has a top edge (210) and a lower edge (220). Further, as seen in FIGS. 8 and 9, the top edge (210) has a top edge height (TEH) that is the elevation of the top edge (210) above the ground plane (GP). Similarly, the lower edge (220) has a lower edge height (LEH) that is the elevation of the lower edge (220) above the ground plane (GP). The highest point along the top edge (210) produces a maximum top edge height (TEH) that is at least 2 inches. Similarly, the lowest point along the lower edge (220) is a minimum lower edge height (LEH).

The top edge (210) and lower edge (220) are identifiable as curves that mark a transition from the curvature of the face (200) to adjoining regions of the club head (100), such as the crown section (400), the sole section (300), or a transition region (230) between the face (200) and the crown section (400) or sole section (300) (see, e.g., FIGS. 26B-C). To identify the top edge (210) and lower edge (220) on an actual golf club head, a three-dimensional scanned image of the club head (100) may be analyzed and a best fit approximation of the roll curvature in a plane containing the crown

apex (410) may be determined for the face (200) based upon the location of all scanned points that are within 22 mm above and below the face center. Within a given vertical plane that is normal to the face (200), the top edge (210) is then identified in the scanned data as the lowermost point above the face center at which the scanned data deviates by more than a threshold amount (e.g., 0.1 mm) from the best fit roll curvature, and the lower edge (220) is identified as the uppermost point below the face center at which the scanned data deviates by more than the threshold amount from the best fit roll curvature.

One of many significant advances of this embodiment of the present club head (100) is the design of an apex ratio that encourages airflow reattachment on the crown section (400) of the golf club head (100) as close to the face (200) as possible. In other words, the sooner that airflow reattachment is achieved, the better the aerodynamic performance and the smaller the aerodynamic drag force. The apex ratio is the ratio of apex height (AH) to the maximum top edge height (TEH). As previously explained, in many large FB dimension golf club heads the apex height (AH) is no more than the top edge height (TEH). In this embodiment, the apex ratio is at least 1.13, thereby encouraging airflow reattachment as soon as possible.

Still further, this embodiment of the club head (100) has a frontal cross sectional area that is less than 11 square inches. The frontal cross sectional area is the single plane area measured in a vertical plane bounded by the outline of the golf club head (100) when it is resting on the ground plane (GP) at the design lie angle and viewed from directly in front of the face (200). The frontal cross sectional area is illustrated by the cross-hatched area of FIG. 13. It will be apparent to those skilled in the art that the "frontal cross sectional area" described here and illustrated in FIG. 13 is a different parameter from the "projected area of the face portion" (A_f) described and defined below in reference to FIGS. 26-31.

In a further embodiment, a second aerodynamic drag force is introduced, namely the 30 degree offset aerodynamic drag force, as previously explained with reference to FIG. 11. In this embodiment the 30 degree offset normalized aerodynamic drag force is less than 1.3 lbf when exposed to a 100 mph wind parallel to the ground plane (GP) when the high volume aerodynamic golf club head (100) is positioned in a design orientation and the wind is oriented thirty degrees from a vertical plane normal to the face (200) with the wind originating from the heel (116) side of the high volume aerodynamic golf club head (100). In addition to having the face-on normalized aerodynamic drag force less than 1.5 lbf, introducing a 30 degree offset normalized aerodynamic drag force of less than 1.3 lbf further reduces the drop in club head speed associated with large volume, large FB dimension golf club heads.

Yet another embodiment introduces a third aerodynamic drag force, namely the heel normalized aerodynamic drag force, as previously explained with reference to FIG. 12. In this particular embodiment, the heel normalized aerodynamic drag force is less than 1.9 lbf when exposed to a horizontal 100 mph wind directed at the heel (116) with the body (110) oriented to have a vertical shaft axis (SA). In addition to having the face-on normalized aerodynamic drag force of less than 1.5 lbf and the 30 degree offset normalized aerodynamic drag force of less than 1.3 lbf, having a heel normalized aerodynamic drag force of less than 1.9 lbf further reduces the drop in club head speed associated with large volume, large FB dimension golf club heads.

A still further embodiment has recognized that having the apex-to-front radius of curvature (Ra-f) at least 25% less than the apex-to-rear radius of curvature (Ra-r) produces a particularly aerodynamic golf club head (100) further assisting in airflow reattachment and preferred airflow attachment over the crown section (400). Yet another embodiment further encourages quick airflow reattachment by incorporating an apex ratio of the apex height (AH) to the maximum top edge height (TEH) that is at least 1.2. This concept is taken even further in yet another embodiment in which the apex ratio of the apex height (AH) to the maximum top edge height (TEH) is at least 1.25. Again, these large apex ratios produce a bulbous crown section (400) that facilitates airflow reattachment as close to the face (200) as possible, thereby resulting in reduced aerodynamic drag forces and resulting in higher club head speeds.

Reducing aerodynamic drag by encouraging airflow reattachment, or conversely discouraging extended lengths of airflow separation, may be further obtained in yet another embodiment in which the apex-to-front radius of curvature (Ra-f) is less than the apex-to-rear radius of curvature (Ra-r), and the apex-to-rear radius of curvature (Ra-r) is less than the heel-to-toe radius of curvature (Rh-t). Such a shape is contrary to conventional high volume, long FB dimension golf club heads, yet produces a particularly aerodynamic shape.

Taking this embodiment a step further in another embodiment, a high volume aerodynamic golf club head (100) having the apex-to-front radius of curvature (Ra-f) less than 2.85 inches and the heel-to-toe radius of curvature (Rh-t) less than 3.85 inches produces a reduced face-on aerodynamic drag force. Another embodiment focuses on the playability of the high volume aerodynamic golf club head (100) by having a maximum top edge height (TEH) that is at least 2 inches, thereby ensuring that the face area is not reduced to an unforgiving level. Even further, another embodiment incorporates a maximum top edge height (TEH) that is at least 2.15 inches, further instilling confidence in the golfer that they are not swinging a golf club head (100) with a small striking face (200).

The foregoing embodiments may be utilized having even larger FB dimensions. For example, the previously described aerodynamic attributes may be incorporated into an embodiment having a front-to-back dimension (FB) that is at least 4.6 inches, or even further a front-to-back dimension (FB) that is at least 4.75 inches. These embodiments allow the high volume aerodynamic golf club head (100) to obtain even higher MOI values without reducing club head speed due to excessive aerodynamic drag forces.

Yet a further embodiment balances all of the radii of curvature requirements to obtain a high volume aerodynamic golf club head (100) while minimizing the risk of an unnatural appearing golf club head by ensuring that less than 10% of the club head volume is above the elevation of the maximum top edge height (TEH). A further embodiment accomplishes the goals herein with a golf club head (100) having between 5% to 10% of the club head volume located above the elevation of the maximum top edge height (TEH). This range achieves the desired crown apex (410) and radii of curvature to ensure desirable aerodynamic drag while maintaining an aesthetically pleasing look of the golf club head (100).

The location of the crown apex (410) is dictated to a degree by the apex-to-front radius of curvature (Ra-f); however, yet a further embodiment identifies that the crown apex (410) should be behind the forwardmost point on the face (200) a distance that is a crown apex setback dimension

(412), seen in FIG. 9, which is greater than 10% of the FB dimension and less than 70% of the FB dimension, thereby further reducing the period of airflow separation and resulting in desirable airflow over the crown section (400). One particular embodiment within this range incorporates a crown apex setback dimension (412) that is less than 1.75 inches. An even further embodiment balances playability with the volume shift toward the face (200) inherent in the present club head (100) by positioning the performance mass to produce a center of gravity (CG) further away from the forwardmost point on the face (200) than the crown apex setback dimension (412).

Additionally, the heel-to-toe location of the crown apex (410) also plays a significant role in the aerodynamic drag force. The location of the crown apex (410) in the heel-to-toe direction is identified by the crown apex ht dimension (414), as seen in FIG. 8. This figure also introduces a heel-to-toe (HT) dimension which is measured in accordance with USGA rules. The location of the crown apex (410) is dictated to a degree by the heel-to-toe radius of curvature (Rh-t); however, yet a further embodiment identifies that the crown apex (410) location should result in a crown apex ht dimension (414) that is greater than 30% of the HT dimension and less than 70% of the HT dimension, thereby aiding in reducing the period of airflow separation. In an even further embodiment, the crown apex (410) is located in the heel-to-toe direction between the center of gravity (CG) and the toe (118).

The present high volume aerodynamic golf club head (100) has a club head volume of at least 400 cc. Further embodiments incorporate the various features of the above described embodiments and increase the club head volume to at least 440 cc, or even further to the current USGA limit of 460 cc. However, one skilled in the art will appreciate that the specified radii and aerodynamic drag requirements are not limited to these club head sizes and apply to even larger club head volumes. Likewise, a heel-to-toe (HT) dimension of the present club head (100), as seen in FIG. 8, is greater than the FB dimension, as measured in accordance with USGA rules.

As one skilled in the art understands, the hollow body (110) has a center of gravity (CG). The location of the center of gravity (CG) is described with reference to an origin point, seen in FIG. 8. The origin point is the point at which a shaft axis (SA) with intersects with a horizontal ground plane (GP). The hollow body (110) has a bore having a center that defines the shaft axis (SA). The bore is present in club heads having traditional hosels, as well as hosel-less club heads. The center of gravity (CG) is located vertically toward the crown section (400) from the origin point a distance Y_{cg} in a direction orthogonal to the ground plane (GP), as seen in FIG. 8. Further, the center of gravity (CG) is located horizontally from the origin point toward the toe (118) a distance X_{cg} that is parallel to a vertical plane defined by the shaft axis (SA) and parallel to the ground plane (GP). Lastly, the center of gravity (CG) is located a distance Z_{cg} , seen in FIG. 14, from the origin point toward the back (114) in a direction orthogonal to the vertical direction used to measure Y_{cg} and orthogonal to the horizontal direction used to measure X_{cg} .

Several more embodiments, seen in FIGS. 14-25, incorporate a post apex attachment promoting region (420) on the surface of the crown section (400) at an elevation above a maximum top edge plane (MTEP), illustrated in FIGS. 18, 19, and 22, wherein the post apex attachment promoting region (420) begins at the crown apex (410) and extends toward the back (114) of the club head (100). The incorpor-

ration of this post apex attachment promoting region (420) creates a high volume aerodynamic golf club head having a post apex attachment promoting region (100) as seen in several embodiments in FIGS. 14-25. The post apex attachment promoting region (420) is a relatively flat portion of the crown section (400) that is behind the crown apex (410), yet above the maximum top edge plane (MTEP), and aids in keeping airflow attached to the club head (100) once it flows past the crown apex (410).

As with the prior embodiments, the embodiments containing the post apex attachment promoting region (420) include a maximum top edge height (TEH) of at least 2 inches and an apex ratio of the apex height (AH) to the maximum top edge height (TEH) of at least 1.13. As seen in FIG. 14, the crown apex (410) is located a distance from the origin point toward the toe (118) a crown apex x-dimension (416) distance that is parallel to the vertical plane defined by the shaft axis (SA) and parallel to the ground plane (GP).

In this particular embodiment, the crown section (400) includes a post apex attachment promoting region (420) on the surface of the crown section (400). Many of the previously described embodiments incorporate characteristics of the crown section (400) located between the crown apex (410) and the face (200) that promote airflow attachment to the club head (100) thereby reducing aerodynamic drag. The post apex attachment promoting region (420) is also aimed at reducing aerodynamic drag by encouraging the airflow passing over the crown section (400) to stay attached to the club head (100); however, the post apex attachment promoting region (420) is located between the crown apex (410) and the back (114) of the club head (100), while also being above the maximum top edge height (TEH), and thus above the maximum top edge plane (MTEP).

Many conventional high volume, large MOI golf club heads having large FB dimensions have crown sections that often never extend above the face. Further, these prior clubs often have crown sections that aggressively slope down to the sole section. While these designs appear as though they should cut through the air, the opposite is often true with such shapes achieving poor airflow reattachment characteristics and increased aerodynamic drag forces. The present club head (100) has recognized the significance of proper club head shaping to account for rapid airflow reattachment in the crown section (400) trailing the face (200) via the apex ratio, as well as encouraging the to airflow remain attached to the club head (100) behind the crown apex (410) via the apex ratio and the post apex attachment promoting region (420).

With reference to FIG. 14, the post apex attachment promoting region (420) includes an attachment promoting region length (422) measured along the surface of the crown section (400) and orthogonal to the vertical plane defined by the shaft axis (SA). The attachment promoting region length (422) is at least as great as fifty percent of the crown apex setback dimension (412). The post apex attachment promoting region (420) also has an apex promoting region width (424) measured along the surface of the crown section (400) in a direction parallel to the vertical plane defined by the shaft axis (SA). The attachment promoting region width (424) is at least as great as the difference between the crown apex x-dimension (416) and the distance Xcg. The relationship of the attachment promoting region length (422) to the crown apex setback dimension (412) recognizes the natural desire of the airflow to separate from the club head (100) as it passes over the crown apex (410). Similarly, the relationship of the attachment promoting region width (424) to the difference between the crown apex x-dimension (416) and

the distance Xcg recognizes the natural desire of the airflow to separate from the club head (100) as it passes over the crown apex (410) in a direction other than directly from the face (200) to the back (114). Incorporating a post apex attachment promoting region (420) that has the claimed length (422) and width (424) establishes the amount of the club head (100) that is above the maximum top edge plane (MTEP) and behind the crown apex (410). In the past many golf club heads sought to minimize, or eliminate, the amount of club head (100) that is above the maximum top edge plane (MTEP)

While the post apex attachment promoting region (420) has both a length (422) and a width (424), the post apex attachment promoting region (420) need not be rectangular in nature. For instance, FIG. 16 illustrates an elliptical post apex attachment promoting region (420) having both a length (422) and a width (424), which may be thought of as a major axis and a minor axis. Thus, the post apex attachment promoting region (420) may be in the shape of any polygon or curved object including, but not limited to, triangles (equilateral, scalene, isosceles, right, acute, obtuse, etc.), quadrilaterals (trapezoid, parallelogram, rectangle, square, rhombus, kite), polygons, circles, ellipses, and ovals. The post apex attachment promoting region (420) is simply an area on the surface of the crown section (400) possessing the claimed attributes, and one skilled in the art will recognize that it will blend into the rest of the crown section (400) and may be indistinguishable by the naked eye.

Like the previous embodiments having aerodynamic characteristics in front of the crown apex (410), the present embodiment incorporating the post apex attachment promoting region (420) located behind the crown apex (410) also has a face-on normalized aerodynamic drag force of less than 1.5 lbf when exposed to a 100 mph wind parallel to the ground plane (GP) when the high volume aerodynamic golf club head having a post apex attachment promoting region (100) is positioned in a design orientation and the wind is oriented at the front (112) of the high volume aerodynamic golf club head having a post apex attachment promoting region (100), as previously explained in detail.

In a further embodiment, a second aerodynamic drag force is introduced, namely the 30 degree offset aerodynamic drag force, as previously explained with reference to FIG. 11. In this embodiment the 30 degree offset normalized aerodynamic drag force is less than 1.3 lbf when exposed to a 100 mph wind parallel to the ground plane (GP) when the high volume aerodynamic golf club head having a post apex attachment promoting region (100) is positioned in a design orientation and the wind is oriented thirty degrees from a vertical plane normal to the face (200) with the wind originating from the heel (116) side of the high volume aerodynamic golf club head having a post apex attachment promoting region (100). In addition to having the face-on normalized aerodynamic drag force less than 1.5 lbf, introducing a 30 degree offset normalized aerodynamic drag force of less than 1.3 lbf further reduces the drop in club head speed associated with large volume, large FB dimension golf club heads.

Yet another embodiment introduces a third aerodynamic drag force, namely the heel normalized aerodynamic drag force, as previously explained with reference to FIG. 12. In this particular embodiment, the heel normalized aerodynamic drag force is less than 1.9 lbf when exposed to a horizontal 100 mph wind directed at the heel (116) with the body (110) oriented to have a vertical shaft axis (SA). In addition to having the face-on normalized aerodynamic drag force of less than 1.5 lbf and the 30 degree offset normalized

aerodynamic drag force of less than 1.3 lbf, having a heel normalized aerodynamic drag force of less than 1.9 lbf further reduces the drop in club head speed associated with large volume, large FB dimension golf club heads.

Just as the embodiments that don't incorporate a post apex attachment promoting region (420) benefit from a relatively high apex ratio of the apex height (AH) to the maximum top edge height (TEH), so to do the embodiments incorporating a post apex attachment promoting region (420). After all, by definition the post apex attachment promoting region (420) is located above the maximum top edge plane (MTEP), which means that if the apex ratio is less than 1 then there can be no post apex attachment promoting region (420). An apex ratio of at least 1.13 provides for the height of the crown apex (410) that enables the incorporation of the post apex attachment promoting region (420) to reduce aerodynamic drag forces. Yet another embodiment further encourages airflow attachment behind the crown apex (410) by incorporating an apex ratio that is at least 1.2, thereby further increasing the available area on the crown section (400) above the maximum top edge height (TEH) suitable for a post apex attachment promoting region (420). The greater the amount of crown section (400) behind the crown apex (410), but above the maximum top edge height (TEH), and having the claimed attributes of the post apex attachment promoting region (420); the more likely the airflow is to remain attached to the club head (100) as it flows past the crown apex (410) and reduce the aerodynamic drag force.

With reference to FIGS. 14-17, in one of many embodiments the attachment promoting region length (422) is at least as great as seventy five percent of the crown apex setback dimension (412). As the attachment promoting region length (422) increases in proportion to the crown apex setback dimension (412), the amount of airflow separation behind the crown apex (410) is reduced. Further, as the attachment promoting region length (422) increases in proportion to the crown apex setback dimension (412), the geometry of the club head (100) is partially defined in that the amount of crown section (400) above the maximum top edge plane (MTEP) is set, thereby establishing the deviation of the crown section (400) from the crown apex (410) in the area behind the crown apex (410). Thus, at least a portion of the crown section (400) behind the crown apex (410) must be relatively flat, or deviate from an apex plane (AP), seen in FIG. 22, by less than twenty degrees thereby reducing the amount of airflow separation behind the crown apex (410).

In a further embodiment seen in FIG. 15, the apex promoting region width (424) is at least twice as great as the difference between the crown apex x-dimension (416) and the distance Xcg. As the apex promoting region width (424) increases, more airflow coming over the crown apex (410) is exposed to the post apex attachment promoting region (420) further promoting airflow attachment to the club head (100) behind the crown apex (410) and reducing aerodynamic drag force.

Yet another embodiment focuses not solely on the size of the post apex attachment promoting region (420), but also on the location of it. It is helpful to define a new dimension to further characterize the placement of the post apex attachment promoting region (420); namely, as seen in FIG. 17, the hollow body (110) has a crown apex-to-toe dimension (418) measured from the crown apex (410) to the toward-most point on the hollow body (110) in a direction parallel to the vertical plane defined by the shaft axis (SA) and parallel to the ground plane (GP). The present embodiment recognizes the significance of having the major portion of the crown section (400) between the crown apex (410) and

the toe (118) incorporating a post apex attachment promoting region (420). Thus, in this embodiment, the post apex attachment promoting region width (424) is at least fifty percent of the crown apex-to-toe dimension (418). In a further embodiment, at least fifty percent of the crown apex-to-toe dimension (418) includes a portion of the post apex attachment promoting region (420). Generally it is easier to promote airflow attachment to the club head (100) on the crown section (400) behind the crown apex (410) in the region from the crown apex (410) to the toe (118), when compared to the region from the crown apex (410) to the heel (116), because of the previously explained airflow disruption associated with the hosel of the club head (100).

Another embodiment builds upon the post apex attachment promoting region (420) by having at least 7.5 percent of the club head volume located above the maximum top edge plane (MTEP), illustrated in FIG. 18. Incorporating such a volume above the maximum top edge plane (MTEP) increases the surface area of the club head (100) above the maximum top edge height (TEH) facilitating the post apex attachment promoting region (420) and reducing airflow separation between the crown apex (410) and the back (114) of the club head (100). Another embodiment, seen in FIG. 19, builds upon this relationship by incorporating a club head (100) design characterized by a vertical cross-section taken through the hollow body (110) at a center of the face (200) extending orthogonal to the vertical plane through the shaft axis (SA) has at least 7.5 percent of the cross-sectional area located above the maximum top edge plane (MTEP).

As previously mentioned, in order to facilitate the post apex attachment promoting region (420), at least a portion of the crown section (400) has to be relatively flat and not aggressively sloped from the crown apex (410) toward the ground plane (GP). In fact, in one embodiment, a portion of the post apex attachment promoting region (420) has an apex-to-rear radius of curvature (Ra-r), seen in FIG. 20, that is greater than 5 inches. In yet another embodiment, a portion of the post apex attachment promoting region (420) has an apex-to-rear radius of curvature (Ra-r) that is greater than both the bulge and the roll of the face (200). An even further embodiment has a portion of the post apex attachment promoting region (420) having an apex-to-rear radius of curvature (Ra-r) that is greater than 20 inches. These relatively flat portions of the post apex attachment promoting region (420), which is above the maximum top edge plane (MTEP), promote airflow attachment to the club head (100) behind the crown apex (410).

Further embodiments incorporate a post apex attachment promoting region (420) in which a majority of the cross sections taken from the face (200) to the back (114) of the club head (100), perpendicular to the vertical plane through the shaft axis (SA), which pass through the post apex attachment promoting region (420), have an apex-to-rear radius of curvature (Ra-r) that is greater than 5 inches. In fact, in one particular embodiment, at least seventy five percent of the vertical plane cross sections taken perpendicular to a vertical plane passing through the shaft axis (SA), which pass through the post apex attachment promoting region (420), are characterized by an apex-to-rear radius of curvature (Ra-r) that is greater than 5 inches within the post apex attachment promoting region (420); thereby further promoting airflow attachment between the crown apex (410) and the back (114) of the club head (100).

Another embodiment incorporates features that promote airflow attachment both in front of the crown apex (410) and behind the crown apex (410). In this embodiment, seen in FIG. 20, the previously described vertical plane cross sec-

tions taken perpendicular to a vertical plane passing through the shaft axis (SA), which pass through the post apex attachment promoting region (420), also have an apex-to-front radius of curvature (Ra-f) that is less than 3 inches, and wherein at least fifty percent of the vertical plane cross sections taken perpendicular to a vertical plane passing through the shaft axis (SA), which pass through the post apex attachment promoting region (420), are characterized by an apex-to-front radius of curvature (Ra-f) of at least 50% less than the apex-to-rear radius of curvature (Ra-r). This combination of a very curved crown section (400) from the crown apex (410) to the face (200), along with a relatively flat crown section (400) from the crown apex (410) toward the back (114), both being above the maximum top edge plane (MTEP), promotes airflow attachment over the crown section (400) and reduces aerodynamic drag force. Yet another embodiment takes this relationship further and increases the percentage of the vertical plane cross sections taken perpendicular to a vertical plane passing through the shaft axis (SA), previously discussed, to at least seventy five percent of the vertical plane cross sections taken perpendicular to a vertical plane passing through the shaft axis (SA); thus further promoting airflow attachment over the crown section (400) of the club head (100).

The attributes of the claimed crown section (400) tend to keep the crown section (400) distant from the sole section (300). One embodiment, seen in FIGS. 21 and 22, incorporates a skirt (500) connecting a portion of the crown section (400) to the sole section (300). The skirt (500) includes a skirt profile (550) that is concave within a profile region angle (552), seen in FIG. 25, originating at the crown apex (410) wherein the profile region angle (552) is at least 45 degrees. With specific reference to FIG. 21, the concave skirt profile (550) creates a skirt-to-sole transition region (510), also referred to as "SSTR," at the connection to the sole section (300) and the skirt-to-sole transition region (510) has a rearwardmost SSTR point (512) located above the ground plane (GP) at a rearwardmost SSTR point elevation (513). Similarly, a skirt-to-crown transition region (520), also referred to as "SSCR," is present at the connection to the crown section (400) and the skirt-to-crown transition region (520) has a rearwardmost SCTR point (522) located above the ground plane (GP) at a rearwardmost SCTR point elevation (523).

In this particular embodiment the rearwardmost SSTR point (512) and the rearwardmost SCTR point (522) need not be located vertically in-line with one another, however they are both located within the profile region angle (552) of FIG. 25. Referring again to FIG. 21, the rearwardmost SSTR point (512) and the rearwardmost SCTR point (522) are vertically separated by a vertical separation distance (530) that is at least thirty percent of the apex height (AH); while also being horizontally separated in a heel-to-toe direction by a heel-to-toe horizontal separation distance (545), seen in FIG. 23; and horizontally separated in a front-to-back direction by a front-to-back horizontal separation distance (540), seen in FIG. 22. This combination of relationships among the elements of the skirt (500) further promotes airflow attachment in that it establishes the location and elevation of the rear of the crown section (400), and thus a profile of the crown section (400) from the crown apex (410) to the back (114) of the club head (100). Further, another embodiment incorporating a rearwardmost SSTR point elevation (513) that is at least twenty five percent of the rearwardmost SCTR point elevation (523) defines a sole section (300) curvature that promotes airflow attachment on the sole section (300).

In a further embodiment, illustrated best in FIG. 23, the rearwardmost SCTR point (522) is substantially in-line vertically with the crown apex (410) producing the longest airflow path over the crown section (400) along the vertical cross section that passes through the crown apex (410) and thus maximizing the airflow attachment propensity of the crown section (400) design. Another variation incorporates a heel-to-toe horizontal separation distance (545) is at least as great as the difference between the crown apex x-dimension (416) and the distance Xcg. A further embodiment has the front-to-back horizontal separation distance (540) is at least thirty percent of the difference between the apex height (AH) and the maximum top edge height (TEH). These additional relationships further promote airflow attachment to the club head (100) by reducing the interference of other airflow paths with the airflow passing over the post apex attachment promoting region (420).

Another embodiment advancing this principle has the rearwardmost SSTR point (512) is located on the heel (116) side of the center of gravity, and the rearwardmost SCTR point (522) is located on the toe (118) side of the center of gravity, as seen in FIG. 23. An alternative embodiment has both the rearwardmost SSTR point and the rearwardmost SCTR point (522) located on the toe (118) side of the center of gravity, but offset by a heel-to-toe horizontal separation distance (545) that is at least as great as the difference between the apex height (AH) and the maximum top edge height (TEH).

Several more high volume aerodynamic golf club head embodiments, seen in and described by reference to FIGS. 26-40, incorporate a "face portion" having a relatively large projected area of the face portion A_f and having a crown section (400) that defines a relatively large drop contour area (620). In some embodiments, the projected area of the face portion A_f desirably is within the range of 8.3 to 11.25 square inches. More desirably, in some embodiments, A_f is within the range of 8.5 to 10.75 square inches. Even more desirably, in some embodiments, A_f is within the range of 8.75 to 10.75 square inches. In some embodiments, the drop contour area (620) is located at an elevation above a maximum top edge plane (MTEP). As defined below, the drop contour area (CA) is a relatively flat portion of the crown section (400) that surrounds the drop contour crown apex (610) and that aids in keeping airflow attached to the club head (100) once it flows over the crown (400) prior to and past the drop contour crown apex (610).

As discussed above, the present high volume aerodynamic golf club heads have a face (200) that is intended to hit the golf ball. In a transition zone (230) of a club head the face (200) transitions to the external contour of the body (110), as shown in FIGS. 26A-C. The shapes of the face (200) and the transition zone (230) can vary substantially from club-head to club-head and from manufacturer to manufacturer. In view of these differences, it is important to have a standard definition of and method for measuring projected area of the face portion A_f . Part of the task of defining projected area of the face portion A_f is dealing with the hosel (120). The hosel (120) is generally not intended as a ball-impact location and thus should not be included in the determination of projected area of the face portion A_f . Since the hosel (120) serves only to connect the club-head to the shaft of the golf club, and since a few club heads currently available have so-called "internal hosel" configurations, the manner of determining projected area of the face portion A_f should exclude any contributions by the hosel, regardless of the club-head configuration.

For consideration of the high volume aerodynamic golf club heads seen in and described in relation to FIGS. 26-35, the desired manner of determining projected area of the face portion A_f is as follows, described with reference to the club head shown in FIG. 27. The club head includes a body (110), a sole section (300), a face (200) and a hosel (120). The hosel (120) extends along a hosel axis A_h . A "hosel-normal" plane (650) is defined that is normal to the hosel axis A_h . The hosel axis A_h also is the axis of rotation of a cylinder (652) having a radius r_c of 15 mm. The hosel-normal plane (650) is located on the hosel axis A_h such that the cylinder (652) intersects the hosel-normal plane (650) and touches the surface of the body (110) at the point (654). A first cut plane (656) is defined as being parallel to the hosel-normal plane (650) but displaced 1 mm toward the sole (300). The first cut plane (656) can be denoted by the line (658) that can be scribed on the face (200) and used later as a cut-line for removing the hosel (120) from the club-head.

As noted above, the face center (660) of the face (200) is determined in accordance with the USGA "Procedure for Measuring the Flexibility of a Golf Clubhead," Revision 2.0, Mar. 25, 2005, which is incorporated herein by reference. A typical face center (660) is shown in FIG. 28. Turning now to FIG. 29, the club head is rotated such that a normal to the face center (660) is parallel to the ground plane and is oriented in the direction of the target line. A "tangent plane" (662) is defined as being tangent to the face (200) at the face center (660) and normal to the "loft plane" (not shown) of the club head. A best fit bulge radius is then determined within a plane that is parallel to the ground plane and passing through the face center (660), using the face center (660) and two points located at 35 mm on either side of the face center (660). The best fit bulge radius is then extended in a vertical direction (i.e., perpendicular to the ground plane) in both directions (i.e., above and below the face center (660)) and is offset by a distance d_2 of 5 mm toward the rear of the club head to define an offset bulge radius cut plane (664).

The club head desirably is cut first along the offset bulge radius cut plane (664) (FIG. 29) to remove the front portion (666) from the rear portion (668). Then, on the front portion (666) (FIG. 30A), a second cut is made along the first cut plane (656), using the line (658) as a guide, to remove the hosel (120). The resulting face portion (670) (FIG. 30B) is used for determining the projected area of the face portion A_f of the club head onto the X-Y plane.

To determine the projected area of the face portion A_f and turning now to FIG. 31, the face portion (670) is placed adjacent a reference portion (672) (having a precisely known reference area) on a planar background (674). The face portion (670) and reference portion (672) are imaged (preferably digitally) from a position normal to the planar background (674). Photo-editing software is used to detect the edges of, and the number of pixels inside, the reference portion (672) (in one example 259,150 "black" pixels made up the reference area of 7.77 in²). Similarly, the software is used to detect the edges of, and number of pixels inside, the face portion (670) (in the example 298,890 black pixels made up the area of the face portion (670)). The projected area of the face portion is calculated as follows:

$$A_f = P_f * (A_r / P_r)$$

wherein A_f is the projected area of the face portion, P_f is the pixel count in the face portion (670), A_r is the area of the reference portion (672), and P_r is the pixel count in the reference portion (672). In the example, if $A_r = 7.77$ in², $P_r = 298,890$ pixels, and $P_f = 259,150$ pixels, then $A_f = 9.14$ in².

It will be understood that the pixel-counting technique described above is an example of a technique capable of measuring area accurately and precisely. Other area-measurement techniques can be employed in alternative methods

In various embodiments, the projected area of the face portion A_f is generally greater than 8.3 in², desirably in the range of 8.3 to 15.5 in², more desirably in the range of 9.0 to 12.5 in², and most desirably in the range of 9.5 to 10.5 in².

The golf club head (100) embodiments shown in and described in relation to FIGS. 26-35 obtain superior aerodynamic performance through the use of unique club head shapes that satisfy a unique relationship between the projected area of the face portion A_f of the club head and the club head drop contour area (CA). Referring now to FIGS. 32A-B, a method for determining the drop contour area of a club head will be described. As shown, a golf club head (100) includes a club head body (110) having a crown section (400) and a face (200). A center face tangent (630) extends parallel to the ground plane and tangent to the face (200) at the location of the face center (660). With the club head oriented at an absolute lie angle of 55 degrees and a square face angle (i.e., a normal to the face (200) at the face center (660) lies within a target plane), the club head body (110) is pitched upward about the centerface tangent (630) to a pitch angle of 12 degrees. This orientation is referred to herein as the 12 degree pitched up orientation. With the club head body (110) positioned in the 12 degree pitched up orientation, the peak height of the crown section relative to the ground plane is located and designated as the 12 degree pitched up crown apex (610). (See FIG. 32A). A crown apex tangent plane (612) is parallel to the ground plane and is tangent to the crown section (400) at the 12 degree pitched up crown apex (610). An 8 mm drop plane (614) is located parallel to and displaced a distance d_3 of 8 mm downward (toward the ground plane) from the crown apex tangent plane (612). An area within an intersection of the 8 mm drop contour plane (614) and the crown section (400) is designated as the 8 mm drop contour area (620) of the club head body (110).

Using the foregoing methods for measuring projected area of the face portion (A_f) and the 8 mm drop contour area (CA), swing path data was investigated for a number of example golf clubs. For a given golf club head orientation, the drag force of the club head moving through air can be calculated according to the following equation:

$$\text{Drag Force} = 0.5 * \rho * u^2 * C_d * A$$

where ρ is the air density, u is the airspeed of the club head, C_d is the drag coefficient, and A is the projected area of the golf club head. Resolving the equation for the product $C_d * A$ provides the following:

$$C_d * A = \text{Drag Force} / 0.5 * \rho * u^2$$

Through swing path analysis, it was found that the range along the swing path between 6 degree and 12 degree pitched up orientations of the golf club head were the most important for contributing to club head aerodynamics because it is within this range of club head orientation that the club head aerodynamic performance will have the most impact on club head speed. A drag force for the number of example golf clubs described above was measured experimentally under known conditions of air speed and air density. Values for the product of $C_d * A$ were then determined for the golf club heads. These results were then plotted against the measured 8 mm drop contour area for the golf club heads in the 6 degree pitched up orientation. The results are provided in the graph shown in FIG. 33, and show

a high correlation between the 8 mm drop contour area and the aerodynamic performance of the golf club head. Moreover, the results provided in the graph at FIG. 33 demonstrate that a relatively larger 8 mm drop contour area provides a golf club head having improved aerodynamic performance.

Turning next to FIGS. 34-39, a number of prior golf club heads manufactured by the TaylorMade Golf Company ("Comparative Embodiments") and a number of competitor prior golf club heads ("Competitor Club Heads") were analyzed to determine the projected area of the face portion (A_f) and 8 mm drop contour area (CA) at a 12 degree pitched up orientation for each of the club heads. These measurements were then compared to measurements of several novel golf club heads described herein ("Novel Club Heads") in the same 12 degree pitched up orientation. The results show that the novel club heads provide a combination of a relatively large projected area of the face portion (A_f) while maintaining an aerodynamically preferable large value for the 8 mm drop contour area (CA) in a manner that was not shown by the Comparative Embodiments or the Competitor Club Heads.

In particular, as shown in FIG. 34, the results show that the novel club heads had a relationship between projected area of the face portion (A_f) and 8 mm drop contour area (CA) that extends within a region of the graph that is defined in part by the following lower boundary equation:

$$CA = -1.5395 * A_f + 19.127 \quad \text{Eq. 1}$$

In Equation 1, CA is the 8 mm drop contour area (at the 12 degree pitched orientation), expressed in square inches, and A_f is the projected area of the face portion (as defined hereinabove), also expressed in square inches. The novel club head region extends between a projected area of the face portion (A_f) of 8.3 in² to 11.25 in² on the x-axis, and extends between about 6.5 in² down to the boundary of Equation 1 described above on the y-axis. A narrower novel club head region extends between about 6.0 in² and the boundary of Equation 1 on the y-axis, and has an x-axis limit between a projected area of the face portion (A_f) of 8.5 in² to 10.75 in², 8.75 in² to 10.75 in², 9.0 in² to 10.5 in², or 9.0 in² to 10.25 in².

Turning to FIG. 35, an alternative relationship for the novel club heads between projected area of the face portion (A_f) and 8 mm drop contour area (CA) extends within a region of the graph that is defined in part by the following lower boundary equation:

$$CA = -1.5395 * A_f + 19.627 \quad \text{Eq. 2}$$

In Equation 2, CA is the 8 mm drop contour area (at the 12 degree pitched orientation), expressed in square inches, and A_f is the projected area of the face portion (as defined hereinabove), also expressed in square inches. The novel club head region shown in FIG. 35 extends between a projected area of the face portion (A_f) of 8.75 in² to 11.25 in² on the x-axis, and extends between about 6.5 in² down to the boundary of Equation 2 described above on the y-axis. A narrower novel club head region extends between about 6.0 in² and the boundary of Equation 2 on the y-axis, and has an x-axis limit between a projected area of the face portion (A_f) of 9.0 in² to 10.75 in², 9.0 in² to 10.75 in², 9.0 in² to 10.5 in², or 9.0 in² to 10.25 in².

Turning to FIG. 36, another alternative relationship for the novel club heads between projected area of the face portion (A_f) and 8 mm drop contour area (CA) extends within a region of the graph that is defined in part by the following lower boundary equation:

$$CA = -1.5395 * A_f + 19.877 \quad \text{Eq. 3}$$

In Equation 3, CA is the 8 mm drop contour area (at the 12 degree pitched orientation), expressed in square inches, and A_f is the projected area of the face portion (as defined hereinabove), also expressed in square inches. The novel club head region shown in FIG. 36 extends between a projected area of the face portion (A_f) of 8.75 in² to 11.25 in² on the x-axis, and extends between about 6.5 in² down to the boundary of Equation 3 described above on the y-axis. A narrower novel club head region extends between about 6.0 in² and the boundary of Equation 3 on the y-axis, and has an x-axis limit between a projected area of the face portion (A_f) of 9.25 in² to 10.75 in², 9.25 in² to 10.75 in², 9.25 in² to 10.5 in², or 9.25 in² to 10.25 in².

Turning next to FIG. 37, still another alternative relationship between projected area of the face portion (A_f) and 8 mm drop contour area (CA) is defined for novel golf club heads having projected area of the face portion (A_f) values greater than 9.5 in². For these novel golf club heads, the relationship between A_f and CA extends within a region of the graph that is defined in part by the following lower boundary equation:

$$CA = -1.5395 * A_f + 17.625 \quad \text{Eq. 4}$$

In Equation 4, CA is the 8 mm drop contour area (at the 12 degree pitched orientation), expressed in square inches, and A_f is the projected area of the face portion (as defined hereinabove), also expressed in square inches. The novel club head region shown in FIG. 37 extends between a projected area of the face portion (A_f) of 9.5 in² to 11.25 in² on the x-axis, and extends between about 6.5 in² down to the boundary of Equation 4 described above on the y-axis. A narrower novel club head region extends between about 6.0 in² and the boundary of Equation 4 on the y-axis, and has an x-axis limit between a projected area of the face portion (A_f) of 9.5 in² to 10.75 in², 9.5 in² to 10.5 in², 9.5 in² to 10.25 in², or 9.75 in² to 10.25 in².

Turning next to FIG. 38, a still further alternative relationship between projected area of the face portion (A_f) and 8 mm drop contour area (CA) is defined for novel golf club heads having projected area of the face portion (A_f) values greater than 9.5 in². For these novel golf club heads, the relationship between A_f and CA extends within a region of the graph that is defined in part by the following lower boundary equation:

$$CA = -1.5395 * A_f + 18.725 \quad \text{Eq. 5}$$

In Equation 5, CA is the 8 mm drop contour area (at the 12 degree pitched orientation), expressed in square inches, and A_f is the projected area of the face portion (as defined hereinabove), also expressed in square inches. The novel club head region shown in FIG. 38 extends between a projected area of the face portion (A_f) of 9.5 in² to 11.25 in² on the x-axis, and extends between about 6.5 in² down to the boundary of Equation 5 described above on the y-axis. A narrower novel club head region extends between about 6.0 in² and the boundary of Equation 5 on the y-axis, and has an x-axis limit between a projected area of the face portion (A_f) of 9.5 in² to 10.75 in², 9.5 in² to 10.5 in², 9.5 in² to 10.25 in², or 9.75 in² to 10.25 in².

Turning next to FIG. 38, another alternative relationship between projected area of the face portion (A_f) and 8 mm drop contour area (CA) is defined for novel golf club heads having projected area of the face portion (A_f) values greater than 9.5 in². For these novel golf club heads, the relationship between A_f and CA extends within a region of the graph that is defined in part by the following lower boundary equation:

$$CA = -1.5395 * A_f + 19.825$$

Eq. 6

In Equation 6, CA is the 8 mm drop contour area (at the 12 degree pitched orientation), expressed in square inches, and A_f is the projected area of the face portion (as defined hereinabove), also expressed in square inches. The novel club head region shown in FIG. 39 extends between a projected area of the face portion (A_f) of 9.5 in² to 11.25 in² on the x-axis, and extends between about 6.5 in² down to the boundary of Equation 6 described above on the y-axis. A narrower novel club head region extends between about 6.0 in² and the boundary of Equation 6 on the y-axis, and has an x-axis limit between a projected area of the face portion (A_f) of 9.5 in² to 10.75 in², 9.5 in² to 10.5 in², 9.5 in² to 10.25 in², or 9.75 in² to 10.25 in².

In several embodiments, the larger projected area of the face portion (A_f) may be achieved by providing a golf club head (100) that includes one or more parts formed from a lightweight material, including conventional metallic and nonmetallic materials known and used in the art, such as steel (including stainless steel), titanium alloys, magnesium alloys, aluminum alloys, carbon fiber composite materials, glass fiber composite materials, carbon pre-preg materials, polymeric materials, and the like. For example, in some embodiments, the face (200) may be provided as a face insert formed of a composite material. FIG. 40A shows an isometric view of a golf club head (100) including a hollow body (110) having a crown section (400) and a sole section (300). A composite face insert (710) is inserted into a front opening inner wall (714) located in the front portion of the club head body (110). The face insert (710) can include a plurality of score lines (712).

FIG. 40B illustrates an exploded assembly view of the golf club head (100) and a face insert (710) including a composite face insert (722) and a metallic cap (724). In certain embodiments, the metallic cap (724) is a titanium alloy, such as 6-4 titanium or CP titanium. In some embodiments, the metallic cap (724) includes a rim portion (732) that covers a portion of a side wall (734) of the composite insert (722). In other embodiments, the metallic cap (724) does not have a rim portion (732) but includes an outer peripheral edge that is substantially flush and planar with the side wall (734) of the composite insert (722). A plurality of score lines (712) can be located on the metallic cap (724). The composite face insert (710) has a variable thickness and is adhesively or mechanically attached to the insert ear (726) located within the front opening and connected to the front opening inner wall (714). The insert ear (726) and the composite face insert (710) can be of the type described in, e.g., U.S. patent application Ser. Nos. 11/825,138, 11/960,609, and 11/960,610, and U.S. Pat. No. 7,267,620, RE42,544, U.S. Pat. Nos. 7,874,936, 7,874,937, 7,985,146, and 8,096,897 which are incorporated by reference herein in their entirety.

FIG. 40B further shows a heel opening (730) located in the heel region (706) of the club head (100). A fastening member (728) is inserted into the heel opening (730) to secure a sleeve (708) in a locked position as shown. The sleeve (708) is configured to be attached (e.g., by bonding) to the distal end of a shaft, to thereby provide a user-adjustable head-shaft connection assembly. In certain embodiments, the sleeve (708) can have any of several specific design parameters and is capable of providing various face angle and loft angle orientations as described in, for example, U.S. patent application Ser. No. 12/474,973 and U.S. Pat. Nos. 7,887,431 and 8,303,431, which are incorporated by reference herein in their entirety.

According to several additional embodiments, a desired combination of a relatively large projected area of the face portion (A_f) and relatively large 8 mm drop contour area (CA) may be obtained by the provision of thin wall construction for one or more parts of the golf club head. Among other advantages, thin wall construction facilitates the redistribution of material from one part of a club head to another part of the club head. Because the redistributed material has a certain mass, the material may be redistributed to locations in the golf club head to enhance performance parameters related to mass distribution, such as CG location and moment of inertia magnitude. Club head material that is capable of being redistributed without affecting the structural integrity of the club head is commonly called discretionary weight. In some embodiments of the presently described high volume aerodynamic golf club head, thin wall construction enables discretionary weight to be removed from one or a combination of the striking plate, crown, skirt, or sole and redistributed in the form of weight ports and corresponding weights.

Thin wall construction can include a thin sole construction, e.g., a sole with a thickness less than about 0.9 mm but greater than about 0.4 mm over at least about 50% of the sole surface area; and/or a thin skirt construction, e.g., a skirt with a thickness less than about 0.8 mm but greater than about 0.4 mm over at least about 50% of the skirt surface area; and/or a thin crown construction, e.g., a crown with a thickness less than about 0.8 mm but greater than about 0.4 mm over at least about 50% of the crown surface area. In one embodiment, the club head is made of titanium and has a thickness less than 0.65 mm over at least 50% of the crown in order to free up enough weight to achieve the desired CG location.

The thin wall construction can be described according to areal weight as defined by the equation below:

$$AW = \rho \cdot t$$

In the above equation, AW is defined as areal weight, ρ is defined as density, and t is defined as the thickness of the material. In one exemplary embodiment, the golf club head is made of a material having a density, ρ , of about 4.5 g/cm³ or less. In one embodiment, the thickness of a crown or sole portion is between about 0.04 cm and about 0.09 cm. Therefore the areal weight of the crown or sole portion is between about 0.18 g/cm² and about 0.41 g/cm². In some embodiments, the areal weight of the crown or sole portion is less than 0.41 g/cm² over at least about 50% of the crown or sole surface area. In other embodiments, the areal weight of the crown or sole is less than about 0.36 g/cm² over at least about 50% of the entire crown or sole surface area.

In certain embodiments, the thin wall construction may be implemented according to U.S. patent application Ser. No. 11/870,913 and/or U.S. Pat. No. 7,186,190, which are incorporated by reference herein in their entirety.

Several of the features of the high volume aerodynamic golf club heads described herein—including the provision of a relatively large projected area of the face portion (A_f) and relatively large 8 mm drop contour area (CA)—will tend to cause the location of the center of gravity (CG) to be relatively higher (i.e., larger Y_{cg} value) than a comparably constructed golf club head that does not include these features. Through the provision of one or more of the features described above, such as a lightweight face and/or lightweight construction in other parts of the golf club head, along with relocation of discretionary weight to other parts of the club head, several embodiments of the presently

described high volume aerodynamic golf club heads may obtain a desirable downward shift in the location of the center of gravity (CG).

As noted above, the hollow body (110) has center of gravity coordinates (Xcg, Ycg, Zcg) that are described with reference to the origin point, seen in FIG. 8. Alternatively, the location of the vertical component of the center of gravity may be designated by reference to a “horizontal center face plane” (HCFP), which is defined herein as a horizontal plane (i.e., a plane parallel to the ground plane) that passes through the center of the face (200) when the club head is positioned in its design orientation. A vertical component of the location of the center of gravity may be expressed as Vcg, which is the distance of the center of gravity (CG) from the horizontal center face plane (HCFP) in a direction orthogonal to the ground plane (GP). Positive values for Vcg indicate a center of gravity (CG) location above the horizontal center face plane (HCFP), while negative values for Vcg indicate a center of gravity (CG) location below the horizontal center face plane (HCFP). Using this alternative designation, in some embodiments, the hollow body (110) of the high volume aerodynamic golf club head is provided with a center of gravity (CG) such that $V_{cg} \leq 0$, such as $V_{cg} \leq -0.08$ inch, such as $V_{cg} \leq -0.16$ inch.

Several of the high volume aerodynamic golf club embodiments described above in relation to FIGS. 26-40 may also include one or more of the same club head shape and performance features contained in the embodiments described above in relation to FIGS. 7-13. For example, as with the prior embodiments, several of the embodiments containing the large projected area of the face portion (A_f) and large 8 mm drop contour area (CA) may also include a front-to-back dimension (FB) of at least 4.4 inches, such as at least about 4.6 inches, or at least about 4.75 inches. In addition, as with the prior embodiments, several of these embodiments may include a maximum top edge height (TEH) of at least about 2 inches, such as at least about 2.15 inches, and an apex ratio of the apex height (AH) to the maximum top edge height (TEH) of at least 1.13, such as at least 1.2, or at least 1.25.

The high volume aerodynamic golf club head (100) described in relation to FIGS. 26-40 may also have a head volume of at least 400 cc. Further embodiments may incorporate the various features of the above described embodiments and increase the club head volume to at least 440 cc, or even further to the current USGA limit of 460 cc. However, one skilled in the art will appreciate that the specific aerodynamic features are not limited to those club head sizes and will apply to even larger club head volumes.

Moreover, several embodiments of the high volume aerodynamic golf club head (100) described in relation to FIGS. 26-40 may also obtain a first moment of inertia (MOI_y) about a vertical axis through a center of gravity (CG) of the golf club head (100) (see FIG. 7) that is at least 4000 g*cm². Further, several of these embodiments may obtain a second moment of inertia (MOI_x) about a horizontal axis through the center of gravity (CG), as seen in FIG. 9, that is at least 2000 g*cm².

Still other embodiments of the high volume aerodynamic golf club head (100) described in relation to FIGS. 26-40 also have a crown section (400), at least a portion of which between the crown apex (410) and the front (112) may have an apex-to-front radius of curvature (Ra-f) that is less than about 3 inches, such as less than about 2.85 inches. In addition, some embodiments include at least a portion of the crown section between the crown apex (410) and the back (114) of the body that may have an apex-to-rear radius of

curvature (Ra-r) that is less than 3.75 inches, and/or at least a portion of which has a heel-to-toe radius of curvature (Rh-t) that may be less than about 4 inches, such as less than about 3.85 inches. Moreover, still other embodiments include an apex-to-front radius of curvature (Ra-f) that may be at least 25% less than the apex-to-rear curvature (Ra-r). Still other embodiments may demonstrate the following relationship between the curvature radii at the following portions of the crown section (400): $R_{a-f} < R_{a-r} < R_{h-t}$.

Still other embodiments of the club head described in relation to FIGS. 26-40 may be constructed such that less than 10%—such as between 5% to 10%—of the club head volume is located above the elevation of the maximum top edge height (MTEH).

Several additional embodiments may include a crown apex setback dimension (412) that is less than 1.75 inches. Still other embodiments may include a crown apex (410) location that results in a crown apex ht dimension (414) that is greater than 30% of the HT dimension and less than 70% of the HT dimension, thereby aiding in reducing the period of airflow separation. In an even further embodiment, the crown apex (410) may be located in the heel-to-toe direction between the center of gravity (CG) and the toe (118).

Moreover, the high volume aerodynamic golf club head embodiments described above in relation to FIGS. 26-40 may also be provided with the post apex attachment promoting region (420) illustrated above in relation to FIGS. 18, 19, and 22, and having the lengths, widths, shapes, and locations described above in relation to FIGS. 14-25. Still further, these embodiments of the high volume aerodynamic golf club head may also be provided with the skirt profiles (550) described above in relation to FIGS. 21-25.

All of the previously described aerodynamic characteristics with respect to the crown section (400) apply equally to the sole section (300) of the high volume aerodynamic golf club head (100). In other words, one skilled in the art will appreciate that just like the crown section (400) has a crown apex (410), the sole section (300) may have a sole apex. Likewise, the three radii of the crown section (400) may just as easily be three radii of the sole section (300). Thus, all of the embodiments described herein with respect to the crown section (400) are incorporated by reference with respect to the sole section (300).

The various parts of the golf club head (100) may be made from any suitable or desired materials without departing from the claimed club head (100), including conventional metallic and nonmetallic materials known and used in the art, such as steel (including stainless steel), titanium alloys, magnesium alloys, aluminum alloys, carbon fiber composite materials, glass fiber composite materials, carbon pre-preg materials, polymeric materials, and the like. The various sections of the club head (100) may be produced in any suitable or desired manner without departing from the claimed club head (100), including in conventional manners known and used in the art, such as by casting, forging, molding (e.g., injection or blow molding), etc. The various sections may be held together as a unitary structure in any suitable or desired manner, including in conventional manners known and used in the art, such as using mechanical connectors, adhesives, cements, welding, brazing, soldering, bonding, and other known material joining techniques. Additionally, the various sections of the golf club head (100) may be constructed from one or more individual pieces, optionally pieces made from different materials having different densities, without departing from the claimed club head (100).

Numerous alterations, modifications, and variations of the preferred embodiments disclosed herein will be apparent to those skilled in the art and they are all anticipated and contemplated to be within the spirit and scope of the instant club head. For example, although specific embodiments have been described in detail, those with skill in the art will understand that the preceding embodiments and variations can be modified to incorporate various types of substitute and or additional or alternative materials, relative arrangement of elements, and dimensional configurations. Accordingly, even though only few variations of the present club head are described herein, it is to be understood that the practice of such additional modifications and variations and the equivalents thereof, are within the spirit and scope of the club head as defined in the following claims. The corresponding structures, materials, acts, and equivalents of all means or step plus function elements in the claims below are intended to include any structure, material, or acts for performing the functions in combination with other claimed elements as specifically claimed.

We claim:

1. An aerodynamic golf club head comprising:
 - A) a hollow body (110) having a club head volume of at least 400 cc, a face (200) formed of a metallic face material, a sole section (300), a crown section (400), a front (112), a back (114), a heel (116), a toe (118), and a front-to-back dimension (FB) of at least 4.4 inches, wherein
 - i) the hollow body (110) has a bore having a center that defines a shaft axis (SA) which intersects with a horizontal ground plane (GP) to define an origin point;
 - ii) the hollow body (110) has a center of gravity (CG) located:
 - (a) vertically toward the crown section (400) from the origin point a distance Y_{cg} in a direction orthogonal to the ground plane (GP), and vertically toward the crown section (400) from a horizontal center face plane a distance V_{cg} in a direction orthogonal to the horizontal center face plane, wherein the distance V_{cg} is less than or equal to 0 inches;
 - (b) horizontally from the origin point toward the toe (118) a distance X_{cg} that is parallel to a vertical plane defined by the shaft axis (SA) and parallel to the ground plane (GP); and
 - (c) a distance Z_{cg} from the origin toward the back (114) in a direction orthogonal to the vertical direction used to measure Y_{cg} and orthogonal to the horizontal direction used to measure X_{cg} ; and
 - iii) the hollow body (110) includes a metallic body material that has a lower density than the metallic face material;
 - B) the face (200) having a top edge (210) and a lower edge (220), wherein a top edge height (TEH) is the elevation of the top edge (210) above the ground plane (GP), and a lower edge height (LEH) is the elevation of the lower edge (220) above the ground plane (GP), wherein a portion of the top edge height (TEH) is at least 2 inches, and the face has a face thickness that varies from a maximum face thickness to a minimum face thickness, with the maximum face thickness is at least 25% greater than the minimum face thickness; and
 - C) the crown section (400) having a crown apex (410) located an apex height (AH) above the ground plane

(GP), and an apex plane (AP) passes through the crown apex (410) and is parallel to the ground plane (GP), wherein;

- i) the crown apex (410) is located behind the forward-most point on the face (200) a distance that is a crown apex setback dimension (412) measured in a direction toward the back (114) and orthogonal to the vertical direction used to measure Y_{cg} and orthogonal to the horizontal direction used to measure X_{cg} ;
- ii) the crown apex (410) is located a distance from the origin toward the toe (118) a crown apex x-dimension (416) distance that is parallel to the vertical plane defined by the shaft axis (SA) and parallel to the ground plane (GP);
- iii) the crown section (400) includes a post apex attachment promoting region (420) on the surface of the crown section (400) at an elevation above a maximum top edge plane (MTEP) wherein the post apex attachment promoting region (420) begins at the crown apex (410) and extends toward the back (114), and includes:
 - (a) an attachment promoting region length (422) measured along the surface of the crown section (400) and orthogonal to the vertical plane defined by the shaft axis (SA), wherein the attachment promoting region length (422) is at least as great as fifty percent of the crown apex setback dimension (412);
 - (b) an attachment promoting region width (424) measured along the surface of the crown section (400) in a direction parallel to the vertical plane defined by the shaft axis (SA), wherein the attachment promoting region width (424) is at least as great as the difference between the crown apex x-dimension (416) and the distance X_{cg} ; and
 - (c) wherein the post apex attachment promoting region (420) is located above a rotated apex plane, wherein the rotated apex plane is the apex plane (AP) rotated twenty degrees, downward toward the rear (114), about a line passing through the crown apex (410) and parallel to the vertical plane defined by the shaft axis (SA);
- iv) the crown section (400) has a 12 degree pitched up orientation crown apex (610) and defining a 12 degree pitched up/8 mm drop contour area (CA), wherein:
 - (a) the 12 degree pitched up orientation crown apex (610) is located at a peak height of the crown section (400) when the hollow body is positioned in a 12 degree pitched up orientation that includes an absolute lie angle of 55 degrees, a face angle of 0 degrees, and a pitch angle of 12 degrees up;
 - (b) the 12 degree/8 mm drop contour area (CA) is defined as the cross-sectional area of an intersection of the crown section (400) with an offset plane located at an elevation that is 8 mm below the 12 degree pitched up orientation crown apex (610) and parallel to the ground plane (GP) when the hollow body is positioned in the 12 degree pitched up orientation; and
 - (c) wherein the hollow body (110) has a projected area of the face portion (A_f), and wherein the 12 degree pitched up/8 mm drop contour area (CA) is greater than the linear expression:

- v) less than 10% of the club head volume is located above the maximum top edge plane (MTEP); and
- vi) a portion of the crown section (400) at an elevation above the maximum top edge plane (MTEP) has an apex-to-front radius of curvature (Ra-f), an apex-to-rear radius of curvature (Ra-r), and a heel-to-toe radius of curvature (Rh-t), wherein at least a portion of the apex-to-rear radius of curvature (Ra-r) is greater than 5 inches;
- D) the golf club head includes an adjustable loft system.
- 2. The aerodynamic golf club head of claim 1, wherein the metallic body material is an aluminum alloy, the attachment promoting region length (422) is at least as great as 75% of the crown apex setback dimension (412), and the attachment promoting region width (424) is at least twice as the difference between the crown apex x-dimension (416) and the distance Xcg.
- 3. The aerodynamic golf club head of claim 2, wherein the aluminum alloy metallic body material includes a rearward-most point on the hollow body (110).
- 4. The aerodynamic golf club head of claim 3, further including at least one weight attached to the aluminum alloy metallic body material.
- 5. The aerodynamic golf club head of claim 1, wherein the post apex attachment promoting region (420) is composed of nonmetallic material, the attachment promoting region length (422) is at least as great as 75% of the crown apex setback dimension (412), the attachment promoting region width (424) is at least fifty percent of a crown apex-to-toe dimension (418) measured from the crown apex (410) to the towardmost point on the hollow body (110), and the projected area of the face portion (Af) is at least 8.3 square inches.
- 6. The aerodynamic golf club head of claim 1, wherein the crown apex setback dimension (412) is at least 10% of the front-to-back dimension (FB) and less than 1.75 inches, and the crown apex setback dimension (412) is less than a distance from a vertical projection of the center of gravity (CG) on the ground plane (GP) to a second vertical projection of the forwardmost point on the face (200) on the ground plane (GP), the distance Vcg is less than or equal to -0.08 inches, and an apex ratio of the apex height (AH) to the greatest top edge height (TEH) is at least 1.13.
- 7. The aerodynamic golf club head of claim 1, wherein a portion of the top edge height (TEH) is at least 2.15 inches, and the 12 degree pitched up/8 mm drop contour area (CA) is greater than the following linear expression:

$$CA=1.5395*A_f+19.627.$$

- 8. An aerodynamic golf club head comprising:
 - A) a hollow body (110) having a club head volume of at least 400 cc, a face (200), a sole section (300), a crown section (400), a front (112), a back (114), a heel (116), a toe (118), and a front-to-back dimension (FB) of at least 4.4 inches, wherein
 - i) the hollow body (110) has a bore having a center that defines a shaft axis (SA) which intersects with a horizontal ground plane (GP) to define an origin point; and
 - ii) the hollow body (110) has a center of gravity (CG) located:
 - (a) vertically toward the crown section (400) from the origin point a distance Ycg in a direction orthogonal to the ground plane (GP), and vertically toward the crown section (400) from a horizontal center face plane a distance Vcg in a

- direction orthogonal to the horizontal center face plane, wherein the distance Vcg is less than or equal to 0 inches;
- (b) horizontally from the origin point toward the toe (118) a distance Xcg that is parallel to a vertical plane defined by the shaft axis (SA) and parallel to the ground plane (GP); and
- (c) a distance Zcg from the origin toward the back (114) in a direction orthogonal to the vertical direction used to measure Ycg and orthogonal to the horizontal direction used to measure Xcg;
- B) the face (200) having a top edge (210) and a lower edge (220), wherein a top edge height (TEH) is the elevation of the top edge (210) above the ground plane (GP), and a lower edge height (LEH) is the elevation of the lower edge (220) above the ground plane (GP), wherein a portion of the top edge height (TEH) is at least 2 inches; and
- C) the crown section (400) having a crown apex (410) located an apex height (AH) above the ground plane (GP), wherein;
 - i) the crown apex (410) is located behind the forward-most point on the face (200) a distance that is a crown apex setback dimension (412) measured in a direction toward the back (114) and orthogonal to the vertical direction used to measure Ycg and orthogonal to the horizontal direction used to measure Xcg;
 - ii) the crown apex (410) is located a distance from the origin toward the toe (118) a crown apex x-dimension (416) distance that is parallel to the vertical plane defined by the shaft axis (SA) and parallel to the ground plane (GP); iii) the crown section (400) includes a post apex attachment promoting region (420) on the surface of the crown section (400) at an elevation above a maximum top edge plane (MTEP) wherein the post apex attachment promoting region (420) begins at the crown apex (410) and extends toward the back (114), and includes:
 - (a) an attachment promoting region length (422) measured along the surface of the crown section (400) and orthogonal to the vertical plane defined by the shaft axis (SA), wherein the attachment promoting region length (422) is at least as great as fifty percent of the crown apex setback dimension (412);
 - (b) an attachment promoting region width (424) measured along the surface of the crown section (400) in a direction parallel to the vertical plane defined by the shaft axis (SA), wherein the attachment promoting region width (424) is at least as great as the difference between the crown apex x-dimension (416) and the distance Xcg; and
 - (c) wherein the post apex attachment promoting region (420) is located above a rotated apex plane, wherein the rotated apex plane is the apex plane (AP) rotated twenty degrees, downward toward the rear (114), about a line passing through the crown apex (410) and parallel to the vertical plane defined by the shaft axis (SA);
 - iii) a portion of the crown section (400) at an elevation above the maximum top edge plane (MTEP) has at least one of:
 - (a) a portion of the crown section (400) between the crown apex (410) and the back (114) of the hollow body (110) has an apex-to-rear radius of curvature

31

- (Ra-r), wherein at least a portion of the apex-to-rear radius of curvature (Ra-r) is greater than 5 inches; or
- (b) a portion of the crown section (400) has a heel-to-toe radius of curvature (Rh-t), wherein the portion of the heel-to-toe radius of curvature (Rh-t) in contact with the crown apex (410) is less than 4 inches;
- iv) the crown section (400) having a 12 degree pitched up orientation crown apex (610) and defining a 12 degree pitched up/8 mm drop contour area (CA), wherein;
 - (a) the 12 degree pitched up orientation crown apex (610) is located at a peak height of the crown section (400) when the hollow body is positioned in a 12 degree pitched up orientation that includes an absolute lie angle of 55 degrees, a face angle of 0 degrees, and a pitch angle of 12 degrees up;
 - (b) the 12 degree/8 mm drop contour area (CA) is defined as the cross-sectional area of an intersection of the crown section (400) with an offset plane located at an elevation that is 8 mm below the 12 degree pitched up orientation crown apex (610) and parallel to the ground plane (GP) when the hollow body is positioned in the 12 degree pitched up orientation; and
 - (c) wherein the hollow body (110) has a projected area of the face portion (A_f), and wherein the 12 degree pitched up/8 mm drop contour area (CA) is greater than the linear expression:

$$CA = -1.5395 * A_f + 19.127$$

- D) wherein a rearwardmost point on the hollow body (110) is located at a rearward most point elevation (523) that is greater than the distance Y_{cg}.

9. The aerodynamic golf club head of claim 8, wherein a portion of the hollow body (110) including the rearwardmost point is formed of an aluminum alloy, the face has a face thickness that varies from a maximum face thickness to a minimum face thickness, and a first moment of inertia (MOI_y) about a vertical axis through the center of gravity (CG) is at least 4000 g*cm², a second moment of inertia (MOI_x) about a horizontal axis through the center of gravity (CG) is at least 2000 g*cm², the attachment promoting region length (422) is at least as great as 75% of the crown apex setback dimension (412), and the attachment promoting region width (424) is at least twice as the difference between the crown apex x-dimension (416) and the distance X_{cg}.

10. The aerodynamic golf club head of claim 9, wherein the post apex attachment promoting region (420) is composed of nonmetallic material, and the projected area of the face portion (A_f) is at least 8.3 square inches.

11. The aerodynamic golf club head of claim 8, wherein hollow body (110) includes a skirt (500) connecting a portion of the crown section (400) to a portion of the sole section (300), a portion of the skirt (500) having a skirt profile (550) that is concave within a profile region angle (552) of 45 degrees originating at the crown apex (410), the concave skirt profile (550) creating (a) a skirt-to-sole transition region (510) at the connection to the sole section (300) and (b) a skirt-to-crown transition region (520) at the connection to the crown section (400), the skirt-to-sole transition region (510) having a rearwardmost SSTR point (512) at a rearwardmost SSTR point elevation (513), the skirt-to-crown transition region (520) having a rearwardmost SCTR point (522) at a rearwardmost SCTR point

32

elevation (523), wherein a front-to-back horizontal separation distance (540) separates the rearwardmost SSTR point (512) and the rearwardmost SCTR point (522), and the front-to-back horizontal separation distance (540) is at least 30 percent of the difference between the apex height (AH) and the maximum top edge height (TEH), and the distance V_{cg} is less than or equal to -0.08 inches.

12. The aerodynamic golf club head of claim 11, wherein the rearwardmost SSTR point (512) and the rearwardmost SCTR point (522) are vertically separated by a vertical separation distance (530) that is at least 30 percent of the apex height (AH).

13. The aerodynamic golf club head of claim 11, wherein at least one of the rearwardmost SSTR point (512) and the rearwardmost SCTR point (522) are located between the center of gravity and the toe (118).

14. The aerodynamic golf club head of claim 8, wherein an apex ratio of the apex height (AH) to the greatest top edge height (TEH) is at least 1.13, and the 12 degree pitched up/8 mm drop contour area (CA) is greater than the following linear expression:

$$CA = -1.5395 * A_f + 19.627.$$

15. An aerodynamic golf club head comprising:

- A) a hollow body (110) having a club head volume of at least 400 cc, a face (200), a sole section (300), a crown section (400), a front (112), a back (114), a heel (116), a toe (118), and a front-to-back dimension (FB) of at least 4.4 inches, wherein

- i) the hollow body (110) has a bore having a center that defines a shaft axis (SA) which intersects with a horizontal ground plane (GP) to define an origin point; and
- ii) the hollow body (110) has a center of gravity (CG) located:
 - (a) vertically toward the crown section (400) from the origin point a distance Y_{cg} in a direction orthogonal to the ground plane (GP), and vertically toward the crown section (400) from a horizontal center face plane a distance V_{cg} in a direction orthogonal to the horizontal center face plane, wherein the distance V_{cg} is less than or equal to 0 inches;
 - (b) horizontally from the origin point toward the toe (118) a distance X_{cg} that is parallel to a vertical plane defined by the shaft axis (SA) and parallel to the ground plane (GP); and
 - (c) a distance Z_{cg} from the origin toward the back (114) in a direction orthogonal to the vertical direction used to measure Y_{cg} and orthogonal to the horizontal direction used to measure X_{cg};

- B) the face (200) having a top edge (210) and a lower edge (220), wherein a top edge height (TEH) is the elevation of the top edge (210) above the ground plane (GP), and a lower edge height (LEH) is the elevation of the lower edge (220) above the ground plane (GP), wherein a portion of the top edge height (TEH) is at least 2 inches; and

- C) the crown section (400) having a crown apex (410) located an apex height (AH) above the ground plane (GP), wherein;

- i) the crown apex (410) is located behind the forwardmost point on the face (200) a distance that is a crown apex setback dimension (412) measured in a direction toward the back (114) and orthogonal to the vertical direction used to measure Y_{cg} and orthogonal to the horizontal direction used to measure X_{cg};

- ii) the crown apex (410) is located a distance from the origin toward the toe (118) a crown apex x-dimension (416) distance that is parallel to the vertical plane defined by the shaft axis (SA) and parallel to the ground plane (GP);
 - iii) the crown section (400) includes a post apex attachment promoting region (420) on the surface of the crown section (400) at an elevation above a maximum top edge plane (MTEP) wherein the post apex attachment promoting region (420) begins at the crown apex (410) and extends toward the back (114), and includes:
 - (a) an attachment promoting region length (422) measured along the surface of the crown section (400) and orthogonal to the vertical plane defined by the shaft axis (SA), wherein the attachment promoting region length (422) is at least as great as fifty percent of the crown apex setback dimension (412);
 - (b) an attachment promoting region width (424) measured along the surface of the crown section (400) in a direction parallel to the vertical plane defined by the shaft axis (SA), wherein the attachment promoting region width (424) is at least as great as the difference between the crown apex x-dimension (416) and the distance Xcg; and
 - (c) wherein the post apex attachment promoting region (420) is located above a rotated apex plane, wherein the rotated apex plane is the apex plane (AP) rotated twenty degrees, downward toward the rear (114), about a line passing through the crown apex (410) and parallel to the vertical plane defined by the shaft axis (SA);
 - iv) the crown section (400) having a 12 degree pitched up orientation crown apex (610) and defining a 12 degree pitched up/8 mm drop contour area (CA), wherein:
 - (a) the 12 degree pitched up orientation crown apex (610) is located at a peak height of the crown section (400) when the hollow body is positioned in a 12 degree pitched up orientation that includes an absolute lie angle of 55 degrees, a face angle of 0 degrees, and a pitch angle of 12 degrees up;
 - (b) the 12 degree/8 mm drop contour area (CA) is defined as the cross-sectional area of an intersection of the crown section (400) with an offset plane located at an elevation that is 8 mm below the 12 degree pitched up orientation crown apex (610) and parallel to the ground plane (GP) when the hollow body is positioned in the 12 degree pitched up orientation; and
 - (c) wherein the hollow body (110) has a projected area of the face portion (A_f), and wherein the 12 degree pitched up/8 mm drop contour area (CA) is greater than the linear expression:

$$CA = -1.5395 * A_f + 19.127$$
- D) wherein a rearwardmost point on the hollow body (110) is located at a rearward most point elevation (523) that is greater than the distance Ycg; and
- E) wherein hollow body (110) includes a skirt (500) connecting a portion of the crown section (400) to a

portion of the sole section (300), a portion of the skirt (500) having a skirt profile (550), within a profile region angle (552) of 45 degrees originating at the crown apex (410), that creates (a) a skirt-to-sole transition region (510) at the connection to the sole section (300) and (b) a skirt-to-crown transition region (520) at the connection to the crown section (400), the skirt-to-sole transition region (510) having a rearwardmost SSTR point (512) at a rearwardmost SSTR point elevation (513), the skirt-to-crown transition region (520) having a rearwardmost SCTR point (522) at a rearwardmost SCTR point elevation (523), wherein a front-to-back horizontal separation distance (540) separates the rearwardmost SSTR point (512) and the rearwardmost SCTR point (522), and the front-to-back horizontal separation distance (540) is at least 30 percent of the difference between the apex height (AH) and the maximum top edge height (TEH).

16. The aerodynamic golf club head of claim 15, wherein a first portion of the hollow body (110) is formed of a titanium alloy and the face is a fiber composite material face insert adhesively attached to the first portion, and a first moment of inertia (MOI_y) about a vertical axis through the center of gravity (CG) is at least 4000 g*cm², a second moment of inertia (MOI_x) about a horizontal axis through the center of gravity (CG) is at least 2000 g*cm², the attachment promoting region length (422) is at least as great as 75% of the crown apex setback dimension (412), and the attachment promoting region width (424) is at least twice as the difference between the crown apex x-dimension (416) and the distance Xcg.

17. The aerodynamic golf club head of claim 16, wherein a second portion of the hollow body (110) is formed of a polymeric material and includes the rearwardmost point, and the post apex attachment promoting region (420) is composed of nonmetallic material.

18. The aerodynamic golf club head of claim 15, wherein a first moment of inertia (MOI_y) about a vertical axis through the center of gravity (CG) is at least 4000 g*cm², and a second moment of inertia (MOI_x) about a horizontal axis through the center of gravity (CG) is at least 2000 g*cm², and a rearwardmost point on the hollow body (110) is formed of an aluminum alloy.

19. The aerodynamic golf club head of claim 18, further including at least one weight attached to the aluminum alloy metallic body material.

20. The aerodynamic golf club head of claim 17, wherein the crown apex setback dimension (412) is at least 10% of the front-to-back dimension (FB) and less than 1.75 inches, and the crown apex setback dimension (412) is less than a distance from a vertical projection of the center of gravity (CG) on the ground plane (GP) to a second vertical projection of the forwardmost point on the face (200) on the ground plane (GP), and the distance Vcg is less than or equal to -0.08 inches, and the 12 degree pitched up/8 mm drop contour area (CA) is greater than the following linear expression:

$$CA = -1.5395 * A_f + 19.627.$$

* * * * *